



**Mains Pressure
Vitreous Enamel
Domestic Water Heaters
45L Capacity**

**Warranty Statement, Safety,
Warnings and Installation Information**

This water heater must be installed and serviced by a qualified person.
Please leave this guide with the householder.

Contents

Warranty.....	3
Safety, Warnings, Installation Notes	7
Maintenance Requirements	10
Water Supplies.....	11
Installation.....	12
Connections – Plumbing	14
Connections – Electrical.....	15
Commissioning.....	16
Draining The Water Heater.....	16

An electronic copy of the Owner's Guide and Installation Instructions is available upon request, or downloadable from rheem.co.nz/support/manual-and-warranties on the Rheem New Zealand website.



PATENTS

This water heater may be protected by one or more patents or registered designs in the name of Rheem Australia Pty Ltd or Rheem New Zealand Limited.

TRADEMARKS

® Registered trademark of Rheem New Zealand Limited.
TM Trademark of Rheem New Zealand Limited

Note: Every care has been taken to ensure the accuracy in preparation of this publication. No liability can be accepted for any consequences which may arise as a result of its application. Image used for illustrative purposes only, product will vary from that shown.



Install a Rheem®

Rheem New Zealand Limited

475 Rosebank Road, Avondale 1026, PO Box 19011, Avondale, Auckland 1746.
Freephone 0800 657 336 – Email rheem@rheem.co.nz – Website www.rheem.co.nz
All specifications contained in this brochure are subject to change without notice.
Please check the specifications are current at the time of ordering. All information is current at the time of publication (July 2025).

Warranty

RHEEM ELECTRIC MAINS PRESSURE WATER HEATER WARRANTY - NEW ZEALAND ONLY

In addition to your legal right, in New Zealand Rheem New Zealand Limited makes the following promise to the owner. We will repair or, if necessary, replace a defective unit or part of it, which has failed due to faulty manufacture on the following terms and conditions:

1. THE RHEEM WARRANTY – GENERAL

- 1.1 This warranty is given by Rheem New Zealand Limited of 475 Rosebank Road, the manufacturer of Rheem mains pressure water heaters.
- 1.2 Rheem offer a trained and qualified national service network who will repair or replace components at the address of the unit subject to the terms of the Rheem warranty in New Zealand – contact your Rheem Service Centre on 0800 657 335 or by email at rheemnzservice@rheem.co.nz
- 1.3 For details about this warranty, you can contact your Rheem Service Centre in New Zealand on 0800 657 335.

2. TERMS OF THE RHEEM WARRANTY AND EXCLUSIONS TO IT

- 2.1 The decision of whether to repair or replace a faulty component is at Rheem New Zealand Limited's sole discretion.
- 2.2 Rheem water heaters are designed to be used only with Rheem branded ancillary equipment, or certain approved third party equipment as specified by Rheem New Zealand Limited from time to time (if any). Rheem reserves the right to reject a claim under this warranty if any unapproved third party equipment has been used with a Rheem water heater.
- 2.3 Where the unit is installed outside the boundaries of a metropolitan area, defined by Rheem as further than 25 km from a Rheem service centre, the cost of transport, insurance and travelling between the Rheem service centre and the installed site shall be the owner's responsibility.
- 2.4 Where the unit is installed in a position that does not allow safe or ready access, the cost of that access, including the cost of additional materials handling and/or safety equipment, shall be the owner's responsibility. In other words, the cost of dismantling or removing cupboards, doors, walls, roofs or trap doors and the cost of any special equipment to bring the unit to floor or ground level or to a serviceable position is not covered by this warranty.
- 2.5 This warranty only applies to the original and genuine Rheem unit in its original installed location and any genuine Rheem replacement parts. It does not cover any plumbing, gas fitting or electrical parts supplied by the installer, that are not an integral part of the

unit, e.g. pipe-work, pressure limiting valve, stop valves, non-return valves, electrical switches, pumps and fuses.

- 2.6 The Rheem warranty does not cover faults that are a result of:
- a) Accidental damage to the unit or any component, for example Acts of God such as floods, storms, fires, lightning strikes and the like and third party acts or omissions.
 - b) Misuse or abnormal use of the unit.
 - c) Installation or use not in accordance with the Owner's Guide and Installation Instructions, New Zealand Building Code requirements or with relevant statutory and local requirements including failure to install a properly drained safe tray where required by the owners guide and installations.
 - d) Connection at any time to a water supply that does not comply with the water supply guidelines as outlined in the Owner's Guide and Installation Instructions, or poor water quality outside the limits specified in the installation instructions.
 - e) Repairs, attempts to repair or modifications to the unit by a person other than Rheem Service or a Rheem Accredited Service Technician.
 - f) Faulty plumbing or faulty power supply.
 - g) Failure to maintain the unit in accordance with the Owner's Guide and Installation Instructions.
 - h) Transport damage.
 - i) Fair wear and tear from adverse conditions (for example, corrosion).
 - j) Cosmetic defects.
- 2.7 If you require a call out and we find that the fault is not covered by the Rheem warranty, you are responsible for Rheem Service Centre call out costs. If you wish to have the relevant component repaired or replaced by Rheem that service will be at your cost.
- 2.8 Subject to any statutory provisions to the contrary, this warranty excludes any and all claims however arising including under contract or tort for damage to furniture, carpet, walls, foundations or any other consequential loss or incidental expenses either directly or indirectly due to leakage from Rheem unit, or due to leakage from fittings and/ or pipe work of metal, plastic or other materials caused by water temperature, workmanship or other modes of failure.
- 2.9 This warranty excludes to the extent permissible all implied warranties set out in the Contract and Commercial Law Act 2017 (New Zealand) and all guarantees set out in the Consumer Guarantees Act 1993 (New Zealand) to the extent that the goods are acquired for the purpose of resupply in trade consumption in the course of a process of production or manufacture or repairing or treating in trade other goods or fixtures on land.

3. WHAT IS COVERED BY THE RHEEM WARRANTY FOR THE UNITS DETAILED IN THIS DOCUMENT

3.1 The following Warranty terms apply for all Rheem water heaters manufactured after 1st June 2018. Rheem will repair or replace a faulty component of your unit if it fails to operate in accordance with its specifications as follows:

Warranty Cover	The period from date of installation, in which the fault must appear, in order to be covered		*Domestic use is defined as; when the appliance is installed in a single family domestic dwelling.
What components are covered	Domestic use*	Non-domestic use*	What coverage you receive

Mains Pressure	Years		
All components	1	1	Repair or replacement of failed component, or if necessary, replacement of the complete water heater, free of charge, including labour.
Cylinder only (Thermostat setting must be below 70°C)	5	1	Repair or replacement of the complete water heater, free of charge, including labour.
Cylinder only - Vitreous Enamel (Thermostat setting must be below 70°C)	10	3	Repair or replacement of the complete water heater, free of charge. Installation and labour cost are the responsibility of the owner.

4. ENTITLEMENT TO MAKE A CLAIM UNDER THIS WARRANTY

4.1 To be entitled to make a claim under this warranty you need to:

- a) Be the owner of the unit or have consent of the owner to act on their behalf.
- b) Contact Rheem New Zealand Limited Service Department without undue delay after detection of the defect and, in any event, within the applicable warranty period.
- c) Return the faulty component or unit as directed by the Rheem New Zealand Limited Service Department.

4.2 You are not entitled to make a claim under this warranty if your unit:

- a) Does not have its original serial numbers or rating labels.
- b) Is not installed in New Zealand.

5. HOW TO MAKE A CLAIM UNDER THIS WARRANTY

5.1 If you wish to make a claim under this warranty, you need to:

- a) Contact Rheem New Zealand on 0800 657 335 and provide owner's details, address of the unit, a contact number and date of installation of the unit or if that's unavailable, the date of manufacture and serial number (from the rating label on the unit).
- b) A Rheem service centre will arrange for the unit to be tested and assessed on-site.
- c) If Rheem determines that you have a valid warranty claim, Rheem will repair or replace the unit in accordance with this warranty.

5.2 Any expenses incurred in the making of a claim under this warranty will be borne by you.

6. THE CONSUMER GUARANTEES ACT 1993 (NEW ZEALAND)

6.1 Our goods come with guarantees that cannot be excluded under the Consumer Guarantees Act 1993 (New Zealand). If the goods fail to comply with the applicable guarantees set out under the Consumer Guarantees Act 1993 (New Zealand) being the guarantee as to acceptable quality, the guarantee as to correspondence with description or the guarantee as to repair and parts, or if the goods fail to comply with any express guarantee given by Rheem, then you are entitled to a replacement or refund and for compensation for any other reasonably foreseeable loss or damage.

6.2 The Rheem warranty (set out above) is in addition to any rights and remedies that you may have under the Consumer Guarantees Act 1993 (New Zealand).

Safety, Warnings, Installation Notes

It is important you read the following Safety and Warnings, and Relief Valves information.



SAFETY AND WARNINGS

- The water heater will operate until a water temperature of 60°C to 70°C is reached, depending upon the thermostat setting.

These temperatures are sufficiently hot to cause severe scalding. Water at these temperatures may have been plumbed to fixtures where water hotter than 50°C is allowed, such as the kitchen and laundry.

We recommend and it may also be required by regulations that an approved temperature limiting device be fitted into the hot water pipe work to the bathroom and ensuite when this water heater is installed. This will keep the water temperature below 50°C at the bathroom and ensuite. The risk of scald injury will be reduced and still allow hotter water to the kitchen and laundry.

Check the water temperature before use, such as when entering a shower or filling a bath or basin, to ensure it is suitable for the application and will not cause scald injury.

- This water heater is only intended to be operated by persons who have the experience or the knowledge and the capabilities to do so.
- This water heater is not intended to be operated by persons with reduced physical, sensory or mental capabilities i.e. the infirm, or by children. Children should be supervised to ensure they do not interfere with or play with or at the water heater.
- If the electrical conduit to the water heater is damaged, it must be replaced by a qualified person in order to avoid a hazard. Phone Rheem Service or their nearest Accredited Service Agent to arrange for an inspection.
- This water heater uses 220 V – 240 V a.c. power for the electrically operated components. The removal of the front cover will expose 220 V – 240 V a.c. wiring. It must only be removed by a qualified person. Do not operate the water heater with the cover removed.
- This water heater is supplied with a thermostat, an over-temperature cut-out and a combination temperature pressure relief valve. These devices must not be tampered with or removed. The water heater must not be operated unless each of these devices is fitted and is in working order.



DANGER: The operation of the over-temperature cut-out on a thermostat indicates a possibly dangerous situation. If the over-temperature cut-out operates, it must not be reset, and the water heater must be serviced by a qualified person.

- For continued safety of this water heater, it must be installed, operated and maintained in accordance with the Owner's Guide and Installation Instructions.
- Do not modify this water heater.

RELIEF VALVES

Temperature Pressure Relief Valve

This water heater incorporates a temperature pressure relief valve located near the top of the water heater.

It is possible for the valve to discharge a quantity of water through the drain line during each heating period. This quantity should be equal to approximately 1/50 of the hot water used, as water expands by this volume when heated.

Expansion Control Valve

It is mandatory an expansion control valve is fitted to the cold water line to the water heater.

Valve Operation

Continuous leakage of water from either valve and its drain line may indicate a problem with the water heater.



Warning: A relief valve drain must be left open to atmosphere and be installed in a continuously downward direction.

In locations where water pipes are prone to freezing, the relief valve drain line must be insulated and not exceed 300 mm in length before discharging into a tundish through an air gap.

Operate the easing lever on the temperature pressure relief valve and expansion control valve once every six (6) months to clear any deposits and ensure the valve and its drain line are not blocked.



DANGER: Failure to operate the easing lever on the relief valve once every six (6) months may result in the water heater cylinder failing, or under certain circumstances, exploding.

The temperature pressure relief valve should be replaced at intervals not exceeding five (5) years and the expansion control valve should be checked for performance or replaced at intervals not exceeding five (5) years. The checking of the valves performance or replacement should occur more frequently in areas where there is a high incidence of water deposits.

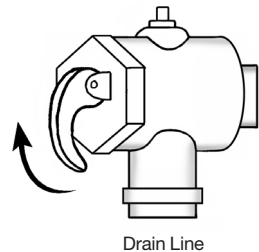

Lift until water flows from the drain line – lower gently



Warning: Water discharged from the temperature pressure relief valve drain line will be hot. Exercise care to avoid any splashing of water by standing clear of the drain line's point of discharge when operating either valve's easing lever.

INSTALLATION NOTES

This water heater must be installed:

- by a qualified person,
- in accordance with the installation instructions,
- in compliance with G12/AS1 (New Zealand), the Plumbing Code of Australia (PCA) and Plumbing Standard AS/NZS 3500.4,
 - This water heater is designed for indoor or outdoor installation.
 - This water heater is intended to be permanently connected to the water mains and not connected by a hose-set. A braided flexible hose or semi-flexible connector may be used for connection to the water heater, where permitted by AS/NZS 3500.4.
- in compliance with the Australian / New Zealand Wiring Rules AS/NZS 3000,
- An isolation switch must be installed at the switchboard in the electrical circuit to the water heater in accordance with the Wiring Rules, so the water heater can be switched off.
 - in compliance with all local codes and regulatory authority requirements.



Warning: This water heater may deliver water at high temperature. Refer to G12/AS1 (New Zealand), the Plumbing Code of Australia, local requirements and these installation instructions to determine if additional delivery temperature control is required. Refer to “**Hot Water Delivery**” on page 13.

Mains pressure water supply

The water heater is supplied with a temperature pressure relief valve with a pressure rating of 1000 kPa. If an expansion control valve has been installed on the cold water line to the water heater, this should have a maximum pressure rating of 850 kPa.

The maximum mains water supply pressure for the water heater is 680 kPa. If the mains supply pressure in your area exceeds these values, a pressure limiting valve must be installed.

The supply pressure should be greater than 350 kPa for true mains pressure operation to be achieved.

To Turn Off The Water Heater

If it is necessary to turn off the water heater:

- Switch off the electrical supply at the water heater isolating switch on the switchboard or at the isolating switch at the water heater (if installed).
- Close the cold water isolation valve at the inlet to the water heater.

To Turn On The Water Heater

- Open the cold water isolation valve fully on the cold water line to the water heater.
- Switch on the electrical supply at the water heater isolating switch on the switchboard and at the isolating switch at the water heater (if installed).

Maintenance Requirements

MINOR MAINTENANCE EVERY SIX MONTHS

It is recommended minor maintenance be performed every six (6) months. Minor maintenance can be performed by the dwelling occupant.

The minor maintenance includes:

- Operate the easing lever on the temperature pressure relief valve. **It is very important the lever is raised and lowered gently.**



Warning: Water discharged from the temperature pressure relief valve drain line will be hot. Exercise care to avoid any splashing of water by standing clear of the drain line's point of discharge when operating the valve's easing lever.

- Operate the easing lever on the expansion control valve (if fitted). **It is very important the lever is raised and lowered gently.**
- Check the drain line from the safe tray (if one is installed) is not blocked.

MAJOR SERVICE EVERY FIVE YEARS

It is recommended a major service be conducted on the water heater every five (5) years.



Warning: Servicing of a water heater must only be carried out by qualified personnel. Phone Rheem Service or their nearest Accredited Service Agent.

Note: The major service and routine replacement of any components, such as the anode and relief valve(s), are not included in the Rheem warranty. A charge will be made for this work. Only genuine replacement parts should be used on this water heater.

The major service includes the following actions:

- Replace the temperature pressure relief valve.
- Inspect and flush the expansion control valve (if fitted). If required, replace the valve.
- Inspect and if required, replace the anode.

If the anode is not replaced, it should be replaced within five (5) years of this service.

- Check the electric heating unit for excessive calcium build-up or corrosion and replace if necessary.
- Visually check the unit for any potential problems.
- Inspect all connections.
- Check the drain line from the safe tray (if one is installed) is not blocked.

Water Supplies

This water heater must be installed in accordance with this advice to be covered by the Rheem warranty.

This water heater is manufactured to suit the water conditions of most public reticulated water supplies. However, there are some known water chemistries which can have detrimental effects on the water heater and its operation and / or life expectancy. If you are unsure of your water chemistry, you may be able to obtain information from your local water supply authority. This water heater should only be connected to a water supply which complies with these guidelines for the Rheem warranty to apply.

ANODE

The vitreous enamel lined cylinder of the water heater is only covered by the Rheem warranty when the total dissolved solids (TDS) content in the water is less than 2500 mg/L and when the correct colour coded anode is used. If an incorrect colour coded anode is used in the water heater, any resultant faults will not be covered by the Rheem warranty. In addition, the use of an incorrect colour coded anode may shorten the life of the water heater cylinder.

The correct colour coded anode must be selected and fitted to the water heater in accordance with the following advice.

Total Dissolved Solids	Anode colour code
0 – 40 mg/L	Green
40 – 150 mg/L	Green or Black
150 – 400 mg/L	Black
400 – 600 mg/L	Black or Blue
600 – 2500 mg/L	Blue
2500 mg/L +	Blue (no cylinder warranty)

The changing of anodes must be carried out by a qualified person.

SATURATION INDEX

Where the saturation index exceeds +0.80, the Rheem warranty does not apply to a standard watts density heating unit. A low watts density heating unit must be used for the warranty to apply to the heating unit.

Contact Rheem Service or their nearest Accredited Service Agent if a replacement heating unit is required.

Installation

THIS WATER HEATER IS NOT SUITABLE FOR POOL HEATING

All packaging materials must be removed from the water heater prior to its installation. This includes the removal of the cardboard base of the carton from the underside of the water heater.

WATER HEATER APPLICATION

This water heater is designed for use in a single-family domestic dwelling for the purpose of heating potable water. Its use in an application other than this may shorten its life. This water heater complies with the Lead Free requirements of G12/AS1 (New Zealand) and the National Construction Code Volume Three (Australia).

If this water heater is to be used where an uninterrupted hot water supply is necessary for the application or business, then there should be back-up redundancy within the hot water system design. This should ensure the continuity of hot water supply in the event that this water heater was to become inoperable for any reason. We recommend you provide advice to the system owner about their needs and building back-up redundancy into the hot water supply system.

WATER HEATER LOCATION

The water heater is suitable for indoor installation only. The water heater should be installed close to the most frequently used outlet.

Make sure the temperature pressure relief valve lever is accessible and the front cover, thermostat and heating unit can be removed for service.

You must be able to read the information on the rating plate. If possible leave headroom of one water heater height so the anode can be inspected or replaced.

The water heater is to be installed at ground or floor level and must stand vertically upright on a stable base as acceptable to local authorities.

Note: The water heater should not be placed in direct contact with a concrete surface that is less than two months old and not fully cured as this may attack the metal coating of the water heater base. A moisture barrier should be used between the two surfaces in this instance. The barrier should extend at least 100 mm from the water heater and may be trimmed after two months.

The water heater must not be installed in an area with a corrosive atmosphere where chemicals are stored or where aerosol propellants are released, as exposure to the corrosive atmosphere may attack the materials used in the water heater.

Remember all local authorities have regulations about putting water heaters into roof spaces.

SAFE TRAY AND SEISMIC RESTRAINTS

Where damage to property can occur in the event of the water heater leaking, the water heater must be installed in a safe tray as per G12 /AS1. AS/NZS 3500.4 also has particular requirements when a safe tray must be installed.

All water heaters must be restrained to protect against seismic forces Refer to G12/AS1 for acceptable solutions.

MAINS WATER SUPPLY

Where the mains water supply pressure exceeds that shown in the table below, an approved pressure limiting valve is required.

Temp press relief valve setting	1000 kPa
Expansion control valve setting *	850 kPa
Maximum mains supply pressure	
With expansion control valve	680 kPa
Without expansion control valve	800 kPa

HOT WATER DELIVERY

This water heater can deliver hot water at temperatures up to 70°C depending upon the thermostat setting. These temperatures are sufficiently hot to cause severe scalding. Water at these temperatures may be plumbed to fixtures where water hotter than 50°C is allowed, such as the kitchen and laundry.

The installing plumber may have a legal obligation to ensure the installation of this water heater meets the water temperature delivery requirements of G12/AS1 (New Zealand) or the Plumbing Code of Australia so that heated water delivered to fixtures and appliances used primarily for personal hygiene is at a temperature which is unlikely to scald.

It is necessary and we recommend that a temperature limiting device be fitted between the water heater and the fixtures and appliances used primarily for personal hygiene such as in a bathroom, ensuite, public amenities or other ablution areas, to reduce the risk of scalding.

REDUCING HEAT LOSSES

The cold water line to and the hot water line from the water heater must be insulated in accordance with the requirements of AS/NZS 3500.4. The insulation must be weatherproof and UV resistant if exposed.

SADDLING PIPE WORK

To prevent damage to the cylinder when attaching pipe clips or saddles to the water heater jacket, we recommend the use of self-drilling screws with a maximum length of 13 mm.

Note: If the cylinder is damaged as a result of attaching pipe clips or saddles to the jacket, any resultant faults will not be covered by the Rheem warranty.

Connections – Plumbing

All plumbing work must be carried out by a qualified person and in accordance with the Standard AS/NZS 3500.4 and all local codes and regulatory authority requirements.

CONNECTION SIZES

- Hot water connection: Rp 3/4
- Cold water connection: Rp 3/4
- Relief valve connection: Rp 1/2

WATER INLET AND OUTLET

An isolation valve and non-return valve must be installed on the cold water line to the water heater. A disconnection union must always be provided at the cold water inlet and hot water outlet on the water heater to allow for disconnection of the water heater.

This water heater is intended to be permanently connected to the water mains.

TEMPERATURE PRESSURE RELIEF VALVE

The temperature pressure relief valve must be fitted before the water heater is operated. Before fitting the relief valve, make sure the probe has not been bent.

To fit the relief valve:

- Seal the thread with an approved thread sealant such as Teflon tape - never hemp. Make sure tape does not hang over the end of the thread.
- Hand tighten the valve into the selected opening, marked "Relief Valve".
- Using a spanner engaged on the valve's spanner flats and applying medium pressure to tighten, turn the relief valve an additional $\frac{1}{2}$ to $1\frac{1}{2}$ turns to secure and make the joint water tight, leaving the valve drain pointing downwards.

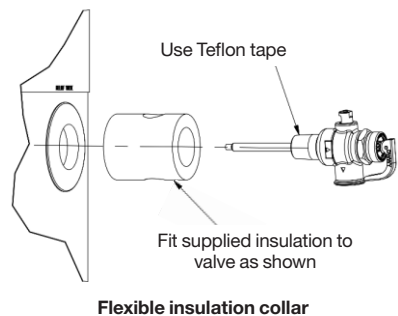
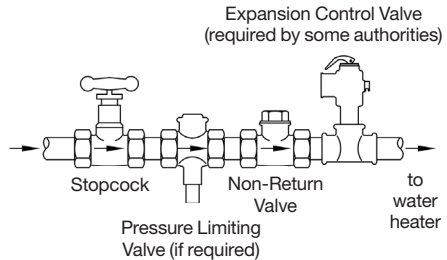

Warning: Do not use a pipe wrench or poor fitting tool on the valve body nor over tighten the valve, as this could damage the valve and prevent safe operation.

- Operate the easing lever on the valve to check the smooth operation of the valve plunger. It is very important the lever is raised and lowered gently. The lever should move smoothly and without undue force.

If the lever cannot be moved or is jerky in its movement, then the valve has been damaged and must be replaced.

- The valve must be insulated with the preformed insulation collar supplied.

Copper drain lines must be fitted to the temperature pressure relief valve and expansion control valve. A drain line from a relief valve must comply with the requirements of AS/NZS 3500.4.

Connections – Electrical

The power supply to the water heater must not be switched on until the water heater is filled with water and a satisfactory megger reading is obtained.

All electrical work and permanent wiring must be carried out by a qualified person and in accordance with the the Wiring Rules AS/NZS 3000 and all local codes and regulatory authority requirements.

WATER HEATER

The water heater must be directly connected to a 220 V - 240 V a.c. 50 Hz mains power supply with an isolating switch installed at the switchboard.

The Wiring Rules AS/NZS 3000:2018 requires a second and lockable isolating switch be installed adjacent to but not on or attached to the water heater, and a residual current device (RCD) installed in the electrical circuit to the water heater. This isolating switch must isolate both circuits to a twin element water heater. The second and lockable isolating switch and RCD may not be required if the installation of this water heater is considered a repair under Clause 1.9.3.2 of the Wiring Rules, i.e., the installation of the water heater is a straight change-over and with a straight disconnect / reconnect of the wiring and where there is no modification to the electrical wiring of the final subcircuit or no increase in electrical load above the circuit capacity.

A flexible 20 mm conduit is required for the electrical cable to the water heater. The conduit is to be connected to the unit with a 20 mm terminator.

Connect the power supply wires directly to the terminal block and earth tab connection, ensuring there are no excess wire loops inside the front cover.

Commissioning

TO FILL AND TURN ON THE WATER HEATER

The power supply to the water heater must not be switched on until the water heater is filled with water and a satisfactory megger reading is obtained.

- Open all of the hot water taps in the house (don't forget the shower).
- Open the cold water isolation valve fully on the cold water line to the water heater.
- Close each tap as water flows freely from it.
- Check the pipe work for leaks.
- Inspect for leaks at the temperature pressure relief valve connection to the water heater.

If a leak is detected, close the cold water isolation valve fully and relieve pressure from the water heater by either operating the easing lever on the temperature pressure relief valve or opening a hot tap. Remove the valve and all of its thread sealant from the threads of the valve. Reapply new thread sealant and refit the valve. Refer to the procedure in **“Temperature Pressure Relief Valve”** on page 14.

- Operate the easing lever on the temperature pressure relief valve to check the smooth operation of the valve plunger and that water discharges freely from the drain line. It is very important the lever is raised and lowered gently. The lever should move smoothly and without undue force.

If the lever cannot be moved or is jerky in its movement, then the valve has been damaged and must be replaced.

- Switch on the electrical supply at the water heater isolating switch on the switchboard and at the isolating switch at the water heater (if installed).
- Turn off the water heater (refer to **“To Turn Off the Water Heater”**).

Draining the water heater

- Close all hot water taps.
- Operate the relief valve lever - do not let the lever snap back or you will damage the valve seat. **It is very important the lever is raised and lowered gently.**

Operating the lever will release the pressure in the water heater.

- Undo the union at the cold water inlet to the water heater and attach a hose to the water heater side of the union. Let the other end of the hose go to a drain.
- Open the relief valve by holding the lever in the raised position. This will let air into the water heater and allow the water to drain through the hose.