

Suits models 621265, 621275, 631265, 631275

Provides Run/Fail signal

On board LED status

HEAVY DUTY GAS BMS INTERFACE MODULE

The Rheem Heavy Duty Gas BMS interface module is designed to interface between individual gas water heaters and the building management system to remotely provide facility managers with real time water heater status.

Features

- The module mounts to the outside of the water heater and is provided with Common, N/O and N/C contacts for field connection by on site trades
- Suits models 621265, 621275, 631265, 631275
- Provides Run/Fail signal via voltage free contacts (common, N/O, N/C)
- Contact rating 1A @ 48V
- Uses water heater's own power supply
- Suitable for indoor and outdoor installation – IP34*
- On board LED status
- Suitable for new installations or retrofit to existing heaters
- Dimensions (mm): 231(h) x 112 (w) x 78 (d)
- **Order Code: 299239**

Operation Modes:

- RUN (N/O) – water heater is heating water or is at temperature (green LED)
- FAIL (N/C) – gas valve lockout or over-temperature cut-out trip or loss of power supply (red LED or no indication)

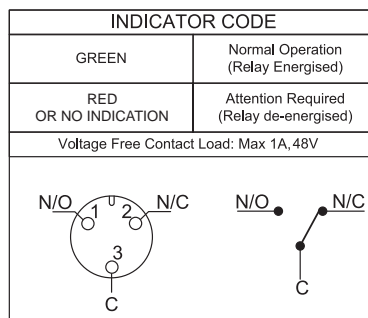

Not to scale

Let Rheem solve your next hot water problem. Phone your local Rheem technical advisory service on 132 552

Rheem Australia Pty Ltd.
1 Alan Street, Rydalmere, New South Wales 2116, Australia
PO Box 7508, Silverwater, New South Wales 2128, Australia.
www.rheem.com.au

Electrical Safety Test Report: 19301548001
Warranty: 12 months parts and labour
*When installed in accordance with installation instructions