

**NEW
PRODUCT**



The Future of Hot Water



AMBIPOWER[®]
MDc-180 HEAT PUMP
WATER HEATER

Our newest
sustainable hot
water solution

Save almost 70% on
your water heating
energy costs*



Advanced water
heating technology



Utilises free energy
from the air



Suitable for up
to 4 people



JOIN THE SMART ENERGY REVOLUTION

SPECIFICATIONS

AMBIPOWER® MDC-180		
MODEL	UNIT	A551180C5
Storage capacity	Litres	178
Boost capacity	Litres	168
Rated Heat Pump power input	Watts	683
Element rating ²	kW	2.4
Recommended electrical circuit	Amps	15
Coefficient of Performance (@19°C) ¹		4.9
Noise Level @ 1 metre ³	dB(A)	48
People per household		Up to 4
Dimensions & specifications		
Tank height	mm	1810
Tank width	mm	532
Tank depth	mm	576
Heater weight - cartoned	kg	116
Heater weight - full	kg	284
Refrigerant		R134a
Water connections & settings		
Inlet & Outlet		Rp 3/4
Temperature Press Relief (TPR) Valve setting	kPa	1000
Expansion Control Valve (ECV) setting	kPa	850
Maximum mains supply pressure		
With expansion control valve	kPa	680
Without expansion control valve	kPa	800

HEAT PUMP PERFORMANCE SPECIFICATIONS			
Ambient air temperature	Recovery rate @ 45°C rise (L/hr)	Average heating capacity (kW)	Coefficient of Performance (COP) ¹
19°C	60	3.1	4.9

BACK-UP ELEMENT RECOVERY RATE @ 240 V TEMPERATURE RISE OF			
Rating (kW)	30°C (litres/hour)	40°C (litres/hour)	50°C (litres/hour)
2.4	69	52	41

COP¹

The Coefficient of Performance for a Heat Pump is the ratio of how much useful heat it produces for water heating to the power input into the water heater. The higher the COP number, the more efficient the Heat Pump is.

Ambient Air Temperature and Humidity

The performance of a Heat Pump changes with ambient air temperature, humidity and incoming water temperature. The warmer the air temperature, the higher the Relative Humidity and the cooler the water temperature, the higher the heating rate of the Heat Pump. Performance specifications stated in relation to the Heat Pump are measured at predefined conditions during its testing.

Average Heating Capacity (kW)

This is how much heating power is put into the water during the heating cycle. It is expressed as an average due to the changes in heating power from the refrigeration cycle as the water is being heated and its temperature increases during the heating cycle.

Recovery Rate @ 45°C rise (L/hr)

This is the number of litres of water that can be heated through a 45°C temperature rise in one hour, e.g. when the air temperature is 19°C, the Heat Pump can heat 60 litres of water from 15°C to 60°C in one hour.

Warranty Periods:

7 years cylinder, 3 years labour on cylinder, 3 years sealed system including labour, 1 year parts and labour. Conditions apply. See the Rheem warranty set out in the Owner's Guide and Installation Instructions or view at www.rheem.co.nz/support/manual-and-warranties.

*Water heating energy savings of almost 70% is from the analysis required by Standard AS/NZS 4234:2008 and is based on the TRNSYS simulation model. Any savings will vary depending upon your location, type of water heater being replaced, hot water consumption and fuel tariff.

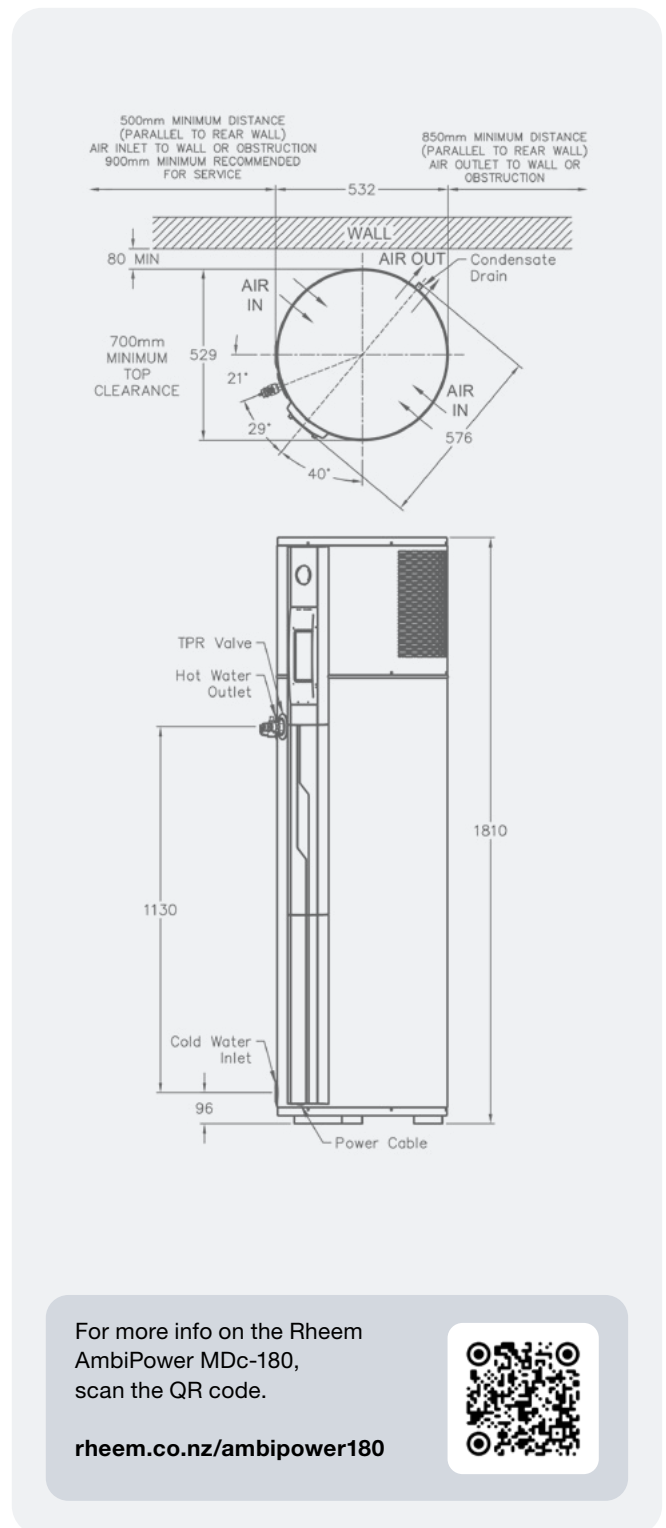

For more info on the Rheem AmbiPower MDC-180, scan the QR code.



rheem.co.nz/ambipower180

1. COP performance specifications according to standard AS/NZS5125 – a COP of 4.9 was measured under test conditions with an ambient air temperature of 19°C over the entire heat-up process. Note that the actual COP of the product at any given time will be impacted by a number of factors, including the ambient and cold-water inlet temperatures at the place of installation and time of day/season of operation.
2. The specified -7°C to 43°C temperature range is the operational range of the Heat Pump. The electric element activates when the ambient air temperature is outside this range and heating of the water is required.
3. Noise Level – A noise level of 48 dB(A) was measured at 1 m from the water heater during a Noise Test conducted to Standard GB/T 23137-2008 in a hemi-anechoic chamber within a laboratory. The noise level when installed may be higher due to sound reflections from adjacent walls and structures.

This document is printed on environmentally responsible paper, produced using FSC® certified 100% Post Consumer Recycled, Process Chlorine Free (PCF) pulp.



Install a Rheem®

Rheem New Zealand Limited

475 Rosebank Road, Avondale 1026, PO Box 19011, Avondale, Auckland 1746. Freephone 0800 657 336 – www.rheem.co.nz

©Registered Trademark of Rheem New Zealand Ltd. ™ Trademark of SAI Global. Materials and specifications are subject to change without notice.