

WATER-TO-WATER HEAT PUMP SPECIFICATIONS

Vented Brazed Plate Heat Exchanger / Rheem IQ Control

95404500

ELECTRICAL INPUT

Voltage/Phase	380 - 415 Volts / 3 Phase / 50 Hz	
Full Load / Locked Rotor (Amps Per Phase)	29.94 FLA / 174 LRA (inc pump)	
Min. Circuit Size	40.0 Amps	
Refrigerant	R134a	
Refrigeration Effect	Heating	Cooling
Nominal Capacity	44.72 kW	35.89 kW
Power Input	8.83 kW	
COP	5.06 COP	4.06 COP
Noise Level	59 dBa @ 3 m	
Rated Load Amps @ 10°C SST / 51°C SCT	25.8 Amps	

TECHNICAL DATA

Compressor	
Make	Copeland
Type	Scroll 20056
Number Per Unit	1
FLA (Full Load Amps)	25.54 Amps (Each)
Voltage / Phase	380 - 415 / 3
Pole/RPM	2/2,900
Air Flow	N/A

HEAT EXCHANGER (Water Side)

	Hot Side (Condenser)	Cold Side (Evaporator)
Type of Water Tube	Stainless Steel	
Design	Plate - Double Wall	Plate - Single Wall
Flow Rate Excl. By Pass	2.20 L/s	1.85 L/s
Max. Outlet Water Temp	65 °C	
Design Pressure Drop	40 kPa	40 kPa
Max. Operating Pressure	1,550 kPa +200/-300 kPa	
Water Pump	AQ33116007	
Max. Pump Current/Power Input	4.4 Amps	670 Watts

GENERAL INFORMATION

Water Connections	Male 2" BSP
Drain	20mm PVC
Defrost	Hot Gas Injection
Cabinet Construction	1.2mm Stucco Aluminium
Approx. Shipping Weight	120 kg
Size L x W x H	1100 mm x 600 mm x 830 mm

COP TABLE

Water Out °C	Cold Water In °C							
	12 °C	14 °C	16 °C	18 °C	20 °C	25 °C	30 °C	35 °C
45 °C	34.75 kW	38.21 kW	39.44 kW	42.00 kW	44.72 kW	52.25 kW	60.98 kW	64.84 kW
	3.97 COP	4.35 COP	4.49 COP	4.77 COP	5.06 COP	5.86 COP	6.73 COP	7.10 COP
50 °C	33.97 kW	37.31 kW	38.49 kW	40.94 kW	43.55 kW	50.77 kW	59.13 kW	62.83 kW
	3.51 COP	3.85 COP	3.97 COP	4.22 COP	4.48 COP	5.19 COP	5.98 COP	6.31 COP
55 °C	33.22 kW	36.42 kW	37.55 kW	39.90 kW	42.39 kW	49.30 kW	57.29 kW	60.82 kW
	3.11 COP	3.41 COP	3.51 COP	3.73 COP	3.96 COP	4.58 COP	5.28 COP	5.58 COP
60 °C	32.49 kW	35.56 kW	36.63 kW	38.88 kW	41.26 kW	47.85 kW	55.46 kW	58.84 kW
	2.75 COP	3.01 COP	3.10 COP	3.29 COP	3.49 COP	4.04 COP	4.65 COP	4.92 COP
65 °C	31.63 kW	34.53 kW	35.55 kW	37.67 kW	39.90 kW	46.09 kW	53.24 kW	56.40 kW
	2.36 COP	2.58 COP	2.65 COP	2.81 COP	2.98 COP	3.44 COP	3.96 COP	4.19 COP

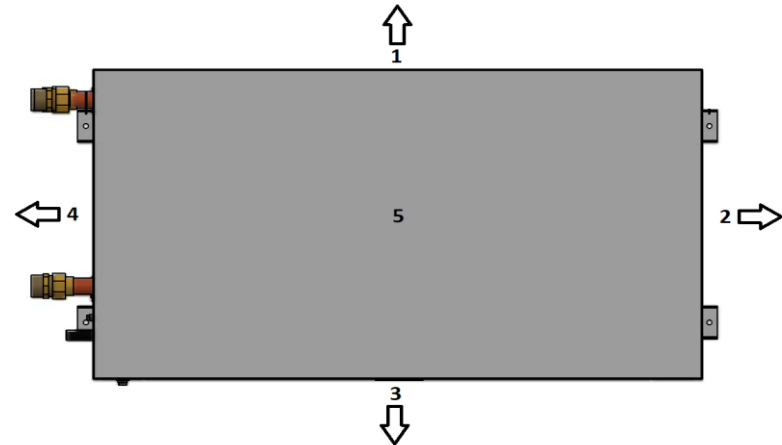

UNIT CLEARANCES

Direction	Description	Minimum Clearance Required
1	Plain Back	Nil
2	Plain Side	Nil
3	Compressor Access	850mm
4	Water Connections	500mm
5	Top - Height Clearance	350mm

Rating Conditions: Cooling: 20°C EWT, 15°C LWT, Heating: 39°C EWT, 45°C LWT



Manufactured In Australia by Rheem

Unit specifications subject to change without notice.

5/02/2026

WATER-TO-WATER HEAT PUMP SPECIFICATIONS

Vented Brazed Plate Heat Exchanger / Rheem IQ Control / Stackable

9540450S

ELECTRICAL INPUT

Voltage/Phase	380 - 415 Volts / 3 Phase / 50 Hz	
Full Load / Locked Rotor (Amps Per Phase)	29.94 FLA / 174 LRA (inc pump)	
Min. Circuit Size	40.0 Amps	
Refrigerant	R134a	
Refrigeration Effect	Heating	Cooling
Nominal Capacity	44.72 kW	35.89 kW
Power Input	8.83 kW	
COP	5.06 COP	4.06 COP
Noise Level	59 dBa @ 3 m	
Rated Load Amps @ 10°C SST / 51°C SCT	25.8 Amps	

TECHNICAL DATA

Compressor	
Make	Copeland
Type	Scroll 20056
Number Per Unit	1
FLA (Full Load Amps)	25.54 Amps (Each)
Voltage / Phase	380 - 415 / 3
Pole/RPM	2/2,900
Air Flow	N/A

HEAT EXCHANGER (Water Side)

	Hot Side (Condenser)	Cold Side (Evaporator)
Type of Water Tube	Stainless Steel	
Design	Plate - Double Wall	Plate - Single Wall
Flow Rate Excl. By Pass	2.20 L/s	1.85 L/s
Max. Outlet Water Temp	65 °C	
Design Pressure Drop	40 kPa	40 kPa
Max. Operating Pressure	1,550 kPa +200/-300 kPa	
Water Pump	AQ33116007	
Max. Pump Current/Power Input	4.4 Amps	670 Watts

GENERAL INFORMATION

Water Connections	Male 2" BSP
Drain	20mm PVC
Defrost	Hot Gas Injection
Cabinet Construction	1.2mm Stucco Aluminium
Approx. Shipping Weight	120 kg
Size L x W x H	1100 mm x 600 mm x 860 mm

COP TABLE

Water Out °C	Cold Water In °C							
	12 °C	14 °C	16 °C	18 °C	20 °C	25 °C	30 °C	35 °C
45 °C	34.75 kW	38.21 kW	39.44 kW	42.00 kW	44.72 kW	52.25 kW	60.98 kW	64.84 kW
	3.97 COP	4.35 COP	4.49 COP	4.77 COP	5.06 COP	5.86 COP	6.73 COP	7.10 COP
50 °C	33.97 kW	37.31 kW	38.49 kW	40.94 kW	43.55 kW	50.77 kW	59.13 kW	62.83 kW
	3.51 COP	3.85 COP	3.97 COP	4.22 COP	4.48 COP	5.19 COP	5.98 COP	6.31 COP
55 °C	33.22 kW	36.42 kW	37.55 kW	39.90 kW	42.39 kW	49.30 kW	57.29 kW	60.82 kW
	3.11 COP	3.41 COP	3.51 COP	3.73 COP	3.96 COP	4.58 COP	5.28 COP	5.58 COP
60 °C	32.49 kW	35.56 kW	36.63 kW	38.88 kW	41.26 kW	47.85 kW	55.46 kW	58.84 kW
	2.75 COP	3.01 COP	3.10 COP	3.29 COP	3.49 COP	4.04 COP	4.65 COP	4.92 COP
65 °C	31.63 kW	34.53 kW	35.55 kW	37.67 kW	39.90 kW	46.09 kW	53.24 kW	56.40 kW
	2.36 COP	2.58 COP	2.65 COP	2.81 COP	2.98 COP	3.44 COP	3.96 COP	4.19 COP

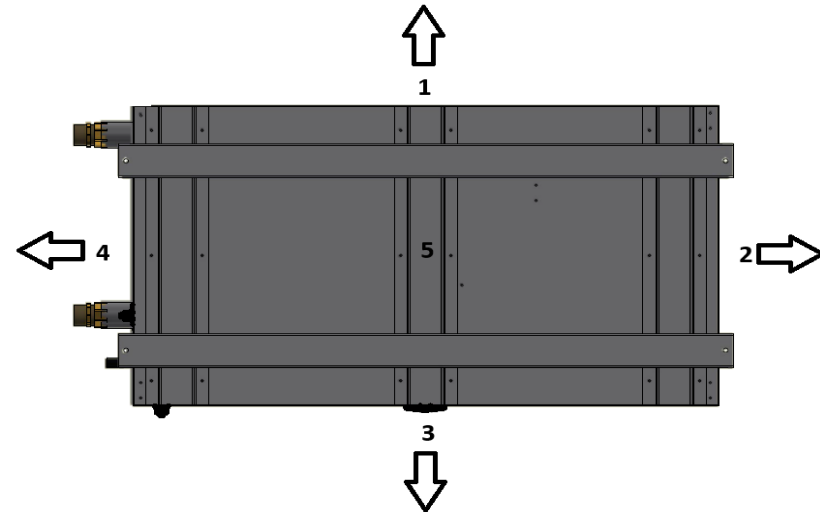

UNIT CLEARANCES

Direction	Description	Minimum Clearance Required
1	Plain Back	Nil
2	Plain Side	Nil
3	Compressor Access	850mm
4	Water Connections	500mm
5	Top - Height Clearance	350mm

Rating Conditions: Cooling: 20°C EWT, 15°C LWT, Heating: 39°C EWT, 45°C LWT



Manufactured In Australia by Rheem
Unit specifications subject to change without notice.