

ELECTRIC COMMERCIAL HEATING UNIT



High Power, High Temperature
Applications

15kW to 180kW Capacity

Low Watts Density, Corrosion
Resistant Elements

Fully Engineered and Integrated
Controls



High Power Electric Heating

The Rheem commercial electric heating unit is designed for large scale commercial heating applications. Up to 180kW are available providing a huge heating capacity of 3000L/hr recovery raised 50°C.

Quality Components

Long service life was top of mind when developing this heating unit. The heating element sheath is made from incoloy 800 providing corrosion protection for all but the harshest water conditions and a low watts heating density of less than 10.6W/cm² improves element life in scaling water conditions.

Electrical components are chosen for long life. For example, induction load suitable AC3 rated contactor is used providing over 1,000,000 cycles.

The electrical enclosure is IP65 rated and made from 304 grade stainless steel, whilst the flange plate is 316L stainless steel with EPDM gasket.

All Models come with sun shields to provide protection from direct sunlight.

Remote Control

The heating unit can be readily interlocked with other control gear such as BMS or via a timer function such as that provided in the HS Series Solar controller, to maximise the solar contribution factor (SCF).

High Temperature Applications

The thermostat incorporates visual temperature display and can be user set to up to 83°C. When coupled with the Rheem RT Series of large capacity stainless steel or carbon steel storage tanks, the heating unit can be placed in the upper or lower tank flange, with the upper flange providing solar boost options or the lower flange being used as a stand alone electric water heater.



DIMENSIONS AND TECHNICAL DATA TABLE											
Model		050350	050351	050352	050353	050354	050355	050356	050357	050358	
Nominal Rating	kW	15	30	45	60	75	100	125	150	180	
Electrical Rating		380 - 415 V AC 50/60Hz Star Connected					380 - 415 V AC 50/60Hz Delta Connected				
Recovery Rate (50°C Rise)	L/hr	258	516	774	1032	1290	1720	2150	2580	3096	
Current per Phase	Amps	21	42	63	83	104	139	174	208	250	
Factory Setting	°C	70	70	70	70	70	70	70	70	70	
Max. Thermostat Setting	°C	90	90	90	90	90	90	90	90	90	
ECO Setting	°C	95	95	95	95	95	95	95	95	95	
Cabinet Width (A)	mm	300	300	300	300	400	400	600	600	600	
Cabinet Height (B)	mm	300	300	300	300	400	400	400	400	400	
Cabinet Depth (C)	mm	218	218	218	218	248	248	322	322	322	
Exposed Length (D)	mm	316	316	316	316	346	346	420	420	420	
Immersed Length (L)	mm	750	750	750	750	750	1250	1250	1500	1500	
Weight (packaged)	kg	47.5	48.2	49	49.8	50.7	53.6	55	56.6	58.2	
Suitable RT Series Tank	Litres	1000 – 5000	1000 – 5000	1000 – 5000	1000 – 5000	1000 – 5000	3000 – 5000	3000 – 5000	5000	5000	

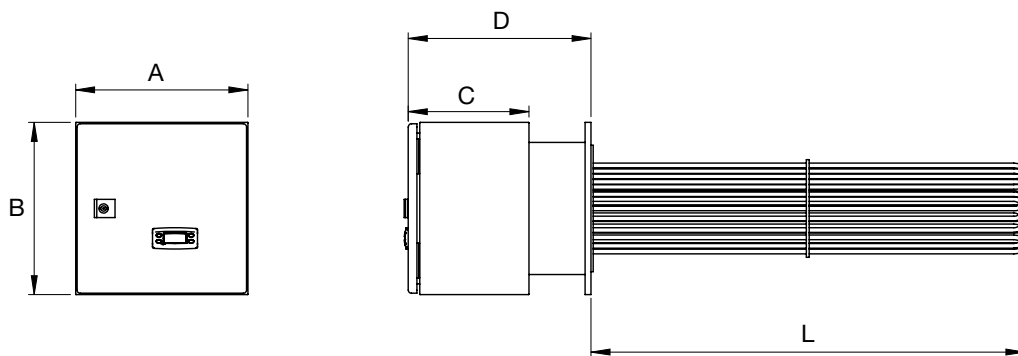

RT Series tank and Heating Unit flange details

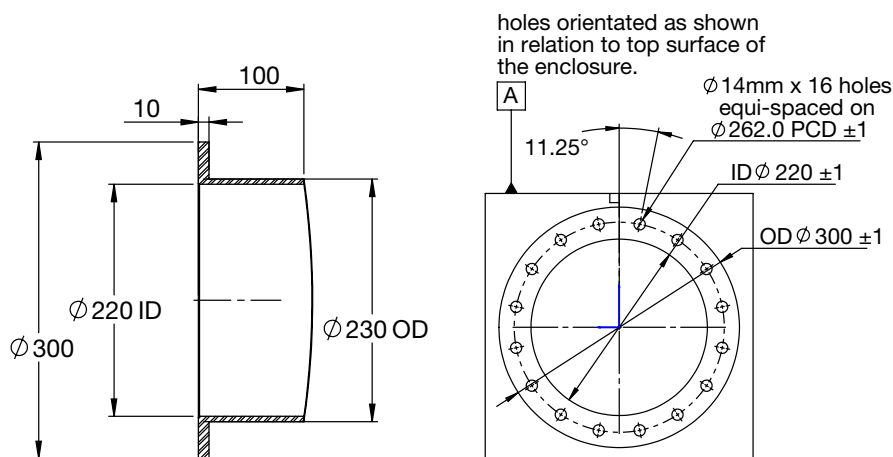

© Registered Trademark of Rheem New Zealand Pty Ltd.
 WaterMark is a Trademark of SAI Global.
 WaterMark applies to heating unit when coupled with Rheem RT Series stainless steel range of storage tanks

Let Rheem solve your next hot water problem. Phone your local Rheem technical advisory service on 0800 657 336

Rheem New Zealand Limited

Freephone 0800 657 336 Freefax 0800 657 337

Telephone 09 829 0200

475 Rosebank Road, Avondale 1026

PO Box 19011, Avondale, Auckland 1746

www.rheem.co.nz

All specifications contained in this brochure are subject to change without notice. Please check the specifications are current at the time of ordering or building to incorporate the appliance. All information is current at the time of publication, (June 2022) but may change without notice.