

## AIR-TO-WATER HEAT PUMP SPECIFICATIONS

Vented Brazed Plate Heat Exchanger / Hi-Static / Rheem IQ Control

**952030H0**

Co-axial Tube-in-Tube Heat Exchanger / Hi-Static / Rheem IQ Control

**952030HV**

### ELECTRICAL INPUT

Voltage/Phase	380 - 415 Volts / 3 Phase / 50 Hz
Full Load / Locked Rotor (Amps Per Phase)	23.2 FLA / 74 LRA
Min. Circuit Size	32.0 Amps
Refrigerant	R1234yf
Nominal Heating Capacity	29.78 kW
Power Input	7.11 kW
COP	4.19 COP
Noise Level	69 dBA @ 3 m
Rated Load Amps @ 8°C SST / 48°C SCT	17.2 Amps

### TECHNICAL DATA

	Compressor	Fan
Reference/Size	20150	630mm
Type	Scroll	Axial EC
Number Per Unit	2	2
FLA (Full Load Amps, each)	9.68 Amps	1.9 Amps
Voltage / Phase	380 - 415 / 3	220 - 240 / 1
Pole/RPM	2 / 2900	EC / 820
Air Flow	N/A	3333 L/s

### HEAT EXCHANGER (Water Side)

Type of Water Tube	Double Wall	
Design	Vented Brazed Plate	Co-axial Tube-in-Tube
Flow Rate Excl. By Pass	2.20 L/s	
Max. Outlet Water Temp	70°C*	
Design Pressure Drop	50 kPa	
Max. Operating Pressure	1550 +200/-300 kPa	

### GENERAL INFORMATION

Water Connections	Male 2" BSP
Drain	20mm Aluminium
Defrost	Reverse Cycle De-ice
Cabinet Construction	1.2mm Stucco Aluminium
Approx. shipping weight	270 kg
Size L x W x H	1850 mm x 945 mm x 1340 mm
Min. Ventilation per Inlet and Outlet	2.64 m <sup>2</sup>

### COP TABLE

Water Out °C	Ambient Temperature °C									
	0 °C	5 °C	10 °C	15 °C	20 °C	25 °C	30 °C	35 °C	40 °C	45 °C
42 °C	19.82 kW	22.03 kW	24.89 kW	27.40 kW	<b>29.78 kW</b>	32.09 kW	33.11 kW	34.15 kW	36.33 kW	39.81 kW
	3.09 COP	3.35 COP	3.69 COP	3.97 COP	<b>4.19 COP</b>	4.50 COP	4.61 COP	4.72 COP	4.96 COP	5.33 COP
45 °C	19.47 kW	21.62 kW	24.41 kW	26.86 kW	29.49 kW	31.43 kW	32.42 kW	33.44 kW	35.56 kW	38.96 kW
	2.91 COP	3.15 COP	3.46 COP	3.72 COP	4.00 COP	4.21 COP	4.31 COP	4.41 COP	4.63 COP	4.97 COP
50 °C	18.69 kW	20.70 kW	23.31 kW	25.60 kW	28.08 kW	29.90 kW	30.83 kW	31.79 kW	33.79 kW	37.00 kW
	2.53 COP	2.72 COP	2.98 COP	3.19 COP	3.42 COP	3.58 COP	3.67 COP	3.75 COP	3.93 COP	4.21 COP
55 °C	18.47 kW	20.44 kW	23.00 kW	25.25 kW	27.68 kW	29.47 kW	30.38 kW	31.33 kW	33.29 kW	36.44 kW
	2.43 COP	2.61 COP	2.85 COP	3.05 COP	3.27 COP	3.42 COP	3.50 COP	3.58 COP	3.75 COP	4.01 COP
60 °C	18.79 kW	19.81 kW	22.24 kW	24.38 kW	26.70 kW	28.40 kW	29.27 kW	30.17 kW	32.04 kW	35.05 kW
	2.27 COP	2.35 COP	2.55 COP	2.73 COP	2.91 COP	3.04 COP	3.11 COP	3.18 COP	3.32 COP	3.54 COP
65 °C	N/A	18.86 kW	21.08 kW	23.04 kW	25.16 kW	26.72 kW	27.53 kW	28.36 kW	30.09 kW	32.87 kW
		1.99 COP	2.14 COP	2.27 COP	2.42 COP	2.52 COP	2.57 COP	2.62 COP	2.73 COP	2.90 COP
70 °C	N/A	N/A	20.52 kW	22.39 kW	24.41 kW	25.91 kW	26.68 kW	27.47 kW	29.13 kW	31.79 kW
			1.96 COP	2.08 COP	2.20 COP	2.29 COP	2.34 COP	2.38 COP	2.48 COP	2.63 COP

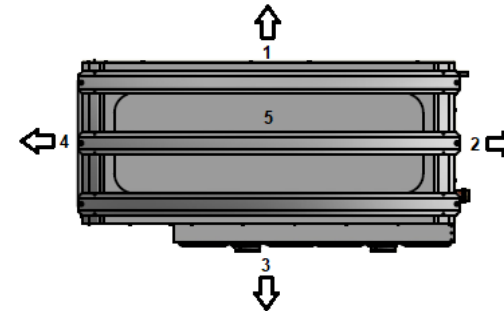

### UNIT CLEARANCES

Direction	Description	Minimum Clearance Required
1	Evaporator Coil	500mm
2	Water Connections	500mm
3	Side - Fan Discharge	3500mm
4	Compressor Access	850mm
5	Top - Height Clearance / Stacking	500mm

When units are placed side by side, allow at least 1000mm distance between evaporator coils.

Rating Conditions: 20°C ambient, 60% RH, 39°C Water in, 42°C Water out

\* Max outlet temperature when ambient is above 10°C