

## AIR-TO-WATER HEAT PUMP SPECIFICATIONS

Vented Brazed Plate Heat Exchanger / Rheem IQ Control

**953015H0**

Co-axial Tube-in-Tube Heat Exchanger / Rheem IQ Control

**953015HV**

### ELECTRICAL INPUT

Voltage/Phase	380 - 415 Volts / 3 Phase / 50 Hz
Full Load / Locked Rotor (Amps Per Phase)	12.5 FLA / 74 LRA
Min. Circuit Size	20.0 Amps
Refrigerant	R1234yf
Nominal Heating Capacity	15.16 kW
Power Input	3.58 kW
COP	4.23 COP
Noise Level	61 dBA @ 3 m
Rated Load Amps @ 8°C SST / 49°C SCT	7.8 Amps

### TECHNICAL DATA

	Compressor	Fan
Reference/Size	20150	450mm
Type	Scroll	Axial EC
Number Per Unit	1	2
FLA (Full Load Amps, each)	9.68 Amps	0.45 Amps
Voltage / Phase	380 - 415 / 3	220 - 240 / 1
Pole/RPM	2 / 2900	EC / 820
Air Flow	N/A	1972 L/s

### HEAT EXCHANGER (Water Side)

Type of Water Tube	Double Wall	
Design	Vented Brazed Plate	Co-axial Tube-in-Tube
Flow Rate Excl. By Pass	1.10 L/s	
Max. Outlet Water Temp	70°C*	
Design Pressure Drop	40 kPa	
Max. Operating Pressure	1550 +200/-300 kPa	

### GENERAL INFORMATION

Water Connections	Male 1 1/4" BSP
Drain	20mm PVC
Defrost	Reverse Cycle De-ice
Cabinet Construction	1.2mm Stucco Aluminium
Approx. shipping weight	140 kg
Size L x W x H	1200 mm x 655 mm x 1035 mm
Min. Ventilation per Inlet and Outlet	1.2 m <sup>2</sup>

### COP TABLE

Water Out °C	Ambient Temperature °C									
	0 °C	5 °C	10 °C	15 °C	20 °C	25 °C	30 °C	35 °C	40 °C	45 °C
42 °C	9.54 kW	10.68 kW	12.38 kW	13.62 kW	<b>15.16 kW</b>	15.95 kW	16.46 kW	16.98 kW	19.10 kW	19.78 kW
	2.98 COP	3.25 COP	3.65 COP	3.93 COP	<b>4.23 COP</b>	4.45 COP	4.56 COP	4.67 COP	5.12 COP	5.27 COP
45 °C	9.42 kW	10.54 kW	12.20 kW	13.43 kW	14.89 kW	15.71 kW	16.21 kW	16.72 kW	18.81 kW	19.48 kW
	2.86 COP	3.11 COP	3.49 COP	3.75 COP	4.06 COP	4.24 COP	4.34 COP	4.45 COP	4.87 COP	5.01 COP
50 °C	9.16 kW	10.22 kW	11.81 kW	12.98 kW	14.37 kW	15.17 kW	15.64 kW	16.13 kW	18.13 kW	18.78 kW
	2.59 COP	2.81 COP	3.13 COP	3.36 COP	3.63 COP	3.78 COP	3.87 COP	3.96 COP	4.33 COP	4.44 COP
55 °C	8.90 kW	9.91 kW	11.42 kW	12.54 kW	13.87 kW	14.63 kW	15.08 kW	15.55 kW	17.46 kW	18.08 kW
	2.34 COP	2.53 COP	2.81 COP	3.00 COP	3.23 COP	3.36 COP	3.44 COP	3.52 COP	3.83 COP	3.93 COP
60 °C	8.66 kW	9.62 kW	11.05 kW	12.11 kW	13.38 kW	14.10 kW	14.53 kW	14.98 kW	16.13 kW	17.40 kW
	2.18 COP	2.35 COP	2.60 COP	2.77 COP	2.98 COP	3.09 COP	3.16 COP	3.23 COP	3.58 COP	3.60 COP
65 °C	N/A	9.49 kW	10.62 kW	11.62 kW	12.81 kW	13.49 kW	13.89 kW	14.31 kW	16.04 kW	16.60 kW
		2.01 COP	2.21 COP	2.35 COP	2.51 COP	2.60 COP	2.66 COP	2.71 COP	2.94 COP	3.01 COP
70 °C	N/A	N/A	10.47 kW	11.44 kW	12.60 kW	13.26 kW	13.66 kW	14.07 kW	15.75 kW	16.30 kW
			2.11 COP	2.24 COP	2.39 COP	2.47 COP	2.52 COP	2.57 COP	2.78 COP	2.85 COP

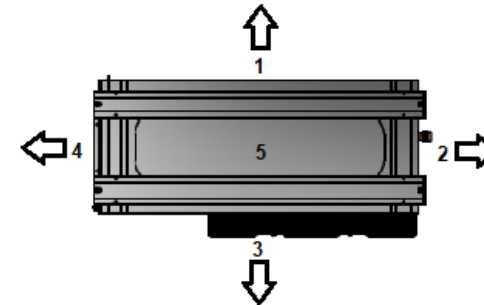

### UNIT CLEARANCES

Direction	Description	Minimum Clearance Required
1	Evaporator Coil	350mm
2	Water Connections	500mm
3	Side - Fan Discharge	2500mm
4	Compressor Access	850mm
5	Top - Height Clearance / Stacking	500mm

When units are placed side by side, allow at least 700mm distance between evaporator coils.

Rating Conditions: 20°C ambient, 60% RH, 39°C Water in, 42°C Water out

\* Max outlet temperature when ambient is above 10°C