

***Owners Guide  
and  
Installation Instructions***



***Commercial Water to Water  
Heat Pump Water Heater***



***Install a Rheem***



**Lead Free**

AS 3488  
WMKA21549

*This water heater must be installed and serviced by a qualified person.*

*Please leave this guide with a responsible officer.*

**Notice to Victorian Customers from the  
Victorian Plumbing Industry Commission.**

**This water heater must be installed by a licensed person as required by  
the Victorian Building Act 1993.**

Only a licensed person will give you a Compliance Certificate, showing that the work complies with all the relevant standards. Only a licensed person will have insurance protecting their workmanship for 6 years. Make sure you use a licensed person to install this water heater and ask for your Compliance Certificate.

**PATENTS**

This water heater may be protected by one or more patents or registered designs.

® Registered trademark of Rheem Australia Pty Ltd.  
™ Trademark of Rheem Australia Pty Ltd.

# CONTENTS

**RESPONSIBLE OFFICER – We recommend you read pages 4 to 18.**

The other pages are intended for the installer but may be of interest.

<b>Contents .....</b>	<b>3</b>
<b>About Your Water Heater.....</b>	<b>4</b>
<b>How Your Water Heater Works .....</b>	<b>8</b>
<b>Regular Care.....</b>	<b>12</b>
<b>Water Supplies .....</b>	<b>14</b>
<b>Save A Service Call.....</b>	<b>16</b>
<b>Installation .....</b>	<b>19</b>
<b>Heat Pump And Tank Assembly .....</b>	<b>31</b>
<b>Manifold Installations.....</b>	<b>35</b>
<b>Connections – Plumbing .....</b>	<b>38</b>
<b>Connections – Electrical .....</b>	<b>40</b>
<b>Commissioning .....</b>	<b>57</b>
<b>Draining The Water Heater .....</b>	<b>78</b>
<b>Trouble Shooting .....</b>	<b>79</b>
<b>Rheem Heat Pump Water Heater Warranty.....</b>	<b>81</b>

# ABOUT YOUR WATER HEATER

## WATER HEATER APPLICATION

This water heater is designed for the purpose of heating potable water by simultaneously reducing building chilling load. Its use in an application other than this may shorten its life.

**This water heater complies with the Lead Free requirements of the National Construction Code Volume Three.**

## MODEL TYPE

Congratulations for choosing a Rheem® commercial water to water (W2W) heat pump water heater. The Rheem W2W heat pump water heater is designed for outdoor or indoor installation.

## HOW HOT SHOULD THE WATER BE?

The heat pump (compressor, evaporator and condenser) will operate until a water temperature of up to set point is reached.

To meet the requirements of the National Plumbing Standard (AS/NZS3500.4) the temperature of the stored water must not be below 60°C.

The factory setting is 61°C. The set point can be adjusted up to 65°C depending on site suitability after consulting with Rheem.

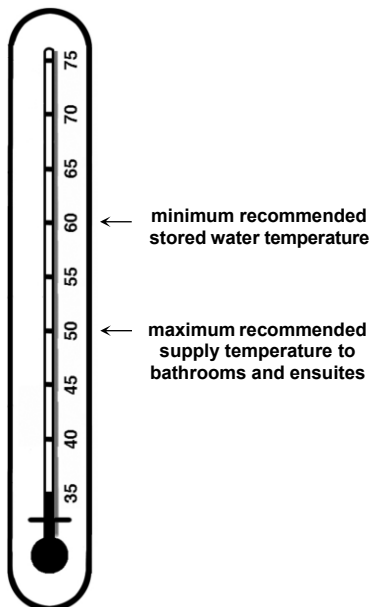

## HOTTER WATER INCREASES THE RISK OF SCALD INJURY

This water heater can deliver water at temperatures which can cause scalding. Check the water temperature before use, such as when entering a shower or filling a bath or basin, to ensure it is suitable for the application and will not cause scald injury.

We recommend and it may also be required by regulations that an approved temperature limiting device be fitted into the hot water pipe work to the bathroom and ensuite when this water heater is installed. This will keep the water temperature below 50°C (55°C in NZ) at the bathroom and ensuite. The risk of scald injury will be reduced and still allow hotter water to the kitchen and laundry.

# ABOUT YOUR WATER HEATER

## TEMPERATURE ADJUSTMENT

### Set Point Quick Setting

Press 'prg' from the main display screen and the Set Point page will appear. Cursor will be on the set temperature. Pressing the up and down keys will adjust the setting in 0.1 increments. Hold down for rapid change. Press 'Enter' to confirm change. Press 'esc' to return to the main display screen. Refer to page 51 for more information.

### WARNING

This water heater is only intended to be operated by persons who have the experience or the knowledge and the capabilities to do so. This water heater is not intended to be operated by persons with reduced physical, sensory or mental capabilities i.e. the infirm, or by children. Children should be supervised to ensure they do not interfere with the water heater.

This water heater uses 415V / 240 V AC electrical power for operation of the control systems and other electrically operated components. The removal of the access cover(s) will expose 415V / 240 V wiring. They must only be removed by a qualified person.

### SAFETY

This water heater is supplied with built in Rheem IQ Controller which controls low and high pressure switches, low temperature cut off, temperature safety switch and flow switch.

Additionally, the compressor is fitted with thermal overload protection, the condenser heat exchanger is fitted with a pressure relief valve and the storage tanks are supplied with a combination temperature pressure relief valve. These devices must not be tampered with or removed. The water heater must not be operated unless each of these devices is fitted and is in working order.

If the electrical supply conduit to the water heater is damaged, it must be replaced by a qualified person in order to avoid a hazard. Phone your nearest Rheem Service Department or Accredited Service Agent (or Service Centre in NZ) to arrange for an inspection.

 **Warning:** For continued safety of this water heater it must be installed, operated and maintained in accordance with the Owner's Guide and Installation Instructions.

# ABOUT YOUR WATER HEATER

**The Rheem warranty may not cover faults if relief valves or other safety devices are tampered with or if the installation is not in accordance with these instructions**

## TO TURN OFF THE WATER HEATER

- Switch off the electrical supply at the isolating switch to the water heater
- Close the cold side and hot side water isolation valve at the inlets to the water heater.

## TO TURN ON THE WATER HEATER

- First, ensure the water is connected to storage tanks, the system is filled with water and all valves between the tanks and the water heater are open
- Open the cold side and hot side water isolation valve fully at the inlets to the water heater.
- Switch on the electrical supply at the isolating switch to the water heater.

**Note:** The water heater may not turn on immediately when it is first switched on, if it is switched on within 20 minutes to 2 hours of it having been switched off at the isolating switch, or the heat pump has just completed a heating cycle. The water heater will wait until the conditions for start-up are favourable in order to protect the compressor from damage. This may take up to 20 minutes to 2 hours. The auxiliary booster will operate instead of the heat pump if the heat pump is in fault or sufficient energy is not available from the chiller.

## HOW DO I KNOW IF THE WATER HEATER IS INSTALLED CORRECTLY?

This water heater must be installed in compliance with the Plumbing Code of Australia (PCA).

**⚠ Warning:** This water heater may deliver water at high temperature. Refer to the Plumbing Code of Australia (PCA), local requirements and these installation instructions to determine if additional delivery temperature control is required.

Installation requirements are shown on **page 19**. The water heater must be installed:

- by a qualified person, and
- in accordance with the installation instructions, and
- in compliance with Standards AS/NZS 3500.4, AS/NZS 3000 and all local codes and regulatory authority requirements.

In New Zealand, the installation must also conform with Clause G12 of the New Zealand Building Code.

# HOW YOUR WATER HEATER WORKS

## DOES THE WATER CHEMISTRY AFFECT THE WATER HEATER?

**This advice relates to the cold water side and hot water side of the heat pump water heater.**

The water heater is suitable for most public water supplies, however some water chemistries may have detrimental effects on the water heater, its components and fittings. **Refer to “Water Supplies” on page 14.** If you are not sure, have your water chemistry checked against the conditions described on **pages 14 to 15.**

## HOW LONG WILL THE WATER HEATER LAST?

Your water heater is supported by a manufacturer’s warranty (refer to **page 76**). There are a number of factors that will affect the length of service the water heater will provide. These include but are not limited to the water chemistry, the water pressure, temperature (inlets and outlets) and the water usage pattern.

### Precautions

Where damage to property can occur in the event of the water heater leaking, the water heater must be installed in a safe tray or be suitably banded. Construction, installation and draining of a safe tray must comply with AS/NZS 3500.4 and all local codes and regulatory authority requirements.

The water heater must be maintained in accordance with the Owner’s Guide and Installation Instructions. Refer to **“Regular Care” on page 12.**

If this water heater is to be used where an uninterrupted hot water supply is necessary for your application, or business you should ensure that you have back up redundancy within the hot water system design. This should ensure the continuity of hot water supply in the event that this water heater were to become inoperable for any reason. We recommend you seek advice from your plumber or specifier about your needs and building back up redundancy into your hot water supply system.

### ENVIRONMENT

At the end of the service life of the heat pump water heater and prior to the water heater being disposed of, a person qualified to work with refrigerants must recover the refrigerant from within the sealed system. The refrigerant must not be vented to atmosphere. Phone your nearest Rheem Service Department or Accredited Service Agent (or Service Centre in NZ) to arrange for an inspection.

# HOW YOUR WATER HEATER WORKS

The Rheem commercial water to water heat pump is an instantaneous type and does not have an integral storage cylinder. The unit is designed to be installed indoors or outdoors. The water heater's evaporator absorbs heat from the returning chilled water circuit or condenser loop and transfers this heat into the potable water. A circulator transfers the heated water to a bank of storage tanks. By taking heat from the chilled water circuit, the heat pump reduces load on chiller as colder water returns to the building chiller circuit. The heat pump produces a sound level of up to 59 dBA (measured at 3 metres) when it is operating.

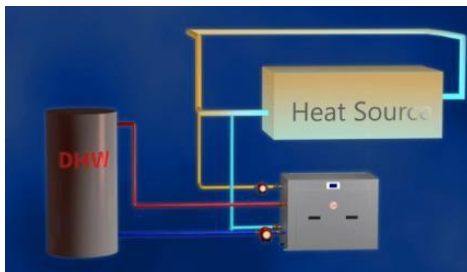

When hot water is drawn off and cold water enters the storage tanks, a remote thermostat activates the compressor and circulating pumps of the water heater. The chiller return water (building heat) is drawn in through the cold side inlet and then through the evaporator (single wall heat exchanger), where heat is transferred to a refrigerant fluid. The fluid is compressed and passes to the condenser (double wall heat exchanger) where heat is transferred into the potable water. The pump circulates water from the bottom of the storage tanks through the heat exchanger and the heated water is circulated back into the storage tanks. This process continues until the water in the storage tanks reaches the set temperature.

The heat pump is designed to operate most efficiently at cold side temperatures between a minimum of 12°C and maximum of 35°C. Operation with higher cold side inlet temperature is possible, however must be engineered in consultation with Rheem. The efficiency of the water heater is relative to the building chilled water circuit temperature and the incoming hot side (potable) water temperature.

Automatic safety controls are fitted to the water heater to provide safe and efficient operation.

## **FREEZE PROTECTION**

Ice may begin to form in the evaporator when the cold side outlet temperature falls below 4°C or the flow rate of cold side water is excessively low or the pump on the cold side fails, and this may damage the evaporator heat exchanger.

# HOW YOUR WATER HEATER WORKS

To prevent this damage, the pumps for both sides of the water heater are sized and supplied by Rheem and the heat pump is supplied with a flow switch sensor and a low temperature cut out switch. The heat pump will terminate its operation if poor flow rate is sensed or the cold side outlet temperature or hot side outlet temperature falls below 5°C.

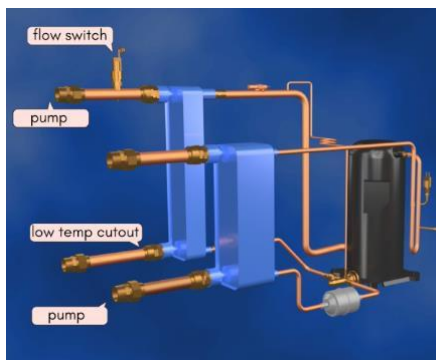

## AUXILIARY BOOST OPERATION

There are two types of auxiliary boost operation, which operate as follows:

### ANTIFREEZE AUXILIARY BOOST OPERATION

When freeze protection activates, the heat pump will cease operating. It is then possible to activate auxiliary heating mode.

In auxiliary heating mode the controller deactivates the heat pump and switches to an auxiliary gas or electric water heater, if installed and activated in the menu. A pump circulates water from the storage tanks through the auxiliary water heater until the set temperature is reached.

When the cold side outlet temperature and hot side outlet temperature rises to 10°C, the auxiliary heating mode is deactivated and the heat pump starts operating again.

For installations using multiple heat pumps in a master/slave configuration, activation of antifreeze auxiliary boost operation on any heat pump activates the auxiliary boost on all LAN connected heat pumps.

### BACKUP AUXILIARY BOOST OPERATION

If the heat pump is in fault mode, the controller switches to an auxiliary gas or electric water heater, if installed and activated in the menu. A pump circulates water from the storage tanks through the auxiliary water heater until the set temperature is reached.

# HOW YOUR WATER HEATER WORKS

For multiple heat pump (Master/Slave) configuration, the auxiliary booster will operate instead of the heat pumps if fifty percent (50%) or more heat pumps are in fault.

For installations using multiple heat pumps in a master/slave configuration; activation of backup auxiliary boost operation on any heat pump activates the auxiliary boost on all LAN connected heat pumps.

The auxiliary boost should be set to 60°C.

The auxiliary boost will remain active until the water heater fault is cleared.

 **Warning:** Rheem will not be responsible for higher utility bills due to excessive use of auxiliary boost heater. It is the customers' responsibility to monitor the system regularly for its correct operation. Rheem recommends monitoring via BMS (modules supplied separately).

## MAINS PRESSURE

The water heater is designed to operate at mains pressure by connecting directly to the mains water supply. If the mains supply pressure in your area exceeds that shown on **page 21**, a pressure limiting valve must be fitted.

## THERMAL CUT OUT

The refrigeration circuit is protected by thermal sensors. These will activate a thermal cut out in the event of excessive heat in the refrigeration system.

If the thermal cut out has activated, the heat pump will not operate for a period of 20 minutes to 2 hours. The water heater will make two more attempts to start up. If the thermal cut out is tripped again after the third attempt, the system will enter lock out and the alarm contacts will close. If connected to a BMS, this will alert the user that the unit is not operating.

The lockout condition can be manually reset by switching the power to the water heater off and then on.

## CONTROL FUNCTIONALITY

A timer can be set through the heat pump control panel to limit the hours of operation of the water heater (e.g. to reduce noise at night).

The operation of the heat pump can also be controlled by setting up tariff option on the control panel to manage operating costs.

Note: depending on the booster configuration there may be insufficient stored energy available for the next peak period if the system is not up to temperature.

# HOW YOUR WATER HEATER WORKS

## SUPERIOR MONITORING

The W2W Heat Pump System is supplied with 11 sensors:

1. Tank temperature sensor
2. Building flow temperature sensor
3. Chilled water inlet temperature sensor
4. Chilled water outlet temperature sensor
5. Hot water inlet temperature sensor
6. Hot water outlet temperature sensor
7. Refrigerant suction side temperature (superheat)
8. Suction pressure transducer
9. Discharge pressure transducer
10. Cold water flow switch
11. Low temperature cut out switch

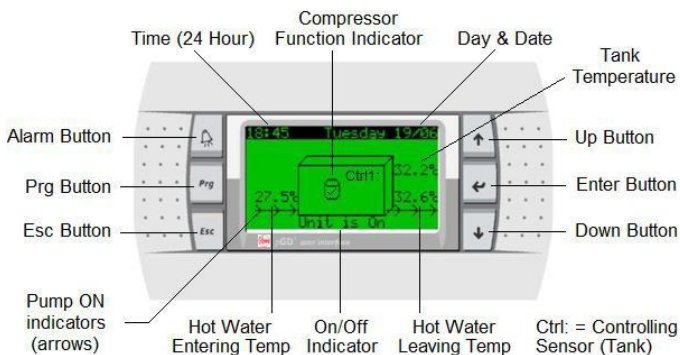

The output of these sensors are displayed on the user friendly control panel to ensure correct system operation.

The system can be connected to BMS via interface cards (Modbus RS485 or BACnet MS-TP or BACnet TCP/IP Ethernet) supplied by Rheem. Contact Rheem for further information on BMS.

# REGULAR CARE

**It is suggested that the commercial heat pump be serviced annually, to retain optimum performance. Servicing must be performed by a suitably qualified person.**

## **Annual Service**

1. Check for leaks at all fittings.
2. Check for signs of excessive corrosion on storage tank(s) jacket(s) and heat pump casing.
3. Check for sludge build up and if necessary drain and flush storage tank(s).
4. Clear hot water pump impellor and ensure free rotation.
5. Clear cold water pump impellor and ensure free rotation.
6. Check condensate drain for blockages – clear if necessary.
7. Isolate power to heat pump and check all electrical connections for signs of overheating due to poor connection.
8. Check for vibration or excessive noise from compressor and hot and cold water pumps.
9. Check refrigerant pressures and adjust refrigerant charge if required. Visually check system for any potential problems.
10. Confirm correct system operation.

## **Five Year Service**

1. As per annual service.
2. Inspect and if required, replace storage tank anode(s). If the anode is not replaced, it should be replaced within three years of this service.
3. Replace temperature and pressure relief valve or expansion control valve.

Refer to Service manual for more information.

# REGULAR CARE

## TEMPERATURE AND PRESSURE RELIEF VALVE AND EXPANSION CONTROL VALVE

A temperature and pressure relief valve is supplied with the storage tanks. In many areas, including South Australia, Western Australia and scaling water areas, an expansion control valve is also fitted to the cold water line to the water heater system. The expansion control valve may discharge a small quantity of water from its drain line during the heating period instead of the temperature pressure relief valve on the storage tanks.

Operate the easing lever on the temperature and pressure relief valve and expansion control valve once every six months. **It is very important you raise and lower the lever gently.**

 **Warning:** Exercise care to avoid any splashing of water, as water discharged from the drain line will be hot. Stand clear of the drain line's point of discharge when operating the valve's lever.

 **DANGER:** Failure to do this may result in the water heater heat exchanger failing.

If water does not flow freely from the drain line when the lever is lifted, then the water heater must be checked Phone Rheem Service or their nearest Accredited Service Agent (or Service Centre in NZ) to arrange for an inspection.

The temperature and pressure relief and expansion control valve should be replaced at intervals not exceeding 5 years, or more frequently in areas where there is a high incidence of water deposits (refer to ["Water Supplies"](#) on **page 14**)

# WATER SUPPLIES

**This water heater must be installed in accordance with this advice to be covered by the Rheem warranty. This advice relates to the cold water side and hot water side of the heat pump water heater.**

This water heater is manufactured to suit the water conditions of most public reticulated water supplies. However, there are some known water chemistries which can have detrimental effects on the water heater and its operation and / or life expectancy. If you are unsure of your water chemistry, you may be able to obtain information from your local water supply authority. This water heater should only be connected to a water supply which complies with these guidelines for the Rheem's warranty to apply.

## **CHANGE OF WATER SUPPLY**

The changing or alternating from one water supply to another can have a detrimental effect on the operation and / or life expectation of a number of components in this water heater.

Where there is a changeover from one water supply to another, e.g. a rainwater tank supply, bore water supply, desalinated water supply, public reticulated water supply or water brought in from another supply, then water chemistry information should be sought from the supplier or it should be tested to ensure the water supply meets the requirements given in these guidelines for the Rheem warranty to apply.

## **SATURATION INDEX**

The saturation index (SI) is used as a measure of the water's corrosive or scaling properties.

Where the saturation index is less than  $-1.0$ , the water is very corrosive and the Rheem warranty does not apply to the water heater. In a corrosive water supply, the water can attack copper parts and cause them to fail.

Where the saturation index exceeds  $+0.40$ , the water is very scaling and an expansion control valve\* must be fitted on the cold water line after the non-return valve. The Rheem warranty does not apply to the water heater.

Water which is scaling may be treated with a water softening device to reduce the saturation index of the water.

Refer to the cold water connection detail on [page 38](#).

## **CHLORIDE AND PH**

Where the chloride level exceeds 250 mg/L the Rheem warranty does not apply to the water heater. In a high chloride water supply, the water can corrode stainless steel parts and cause them to fail.

# WATER SUPPLIES

Where the pH is less than 6.0 the Rheem warranty does not apply to the water heater. pH is a measure of whether the water is alkaline or acid. In an acidic water supply, the water can attack stainless steel parts and cause them to fail.

Water with a pH less than 6.0 may be treated to raise the pH. The water supply from a rainwater tank in a metropolitan area is likely to be corrosive due to the dissolution of atmospheric contaminants.

## **SUMMARY OF WATER CHEMISTRY ADVICE AFFECTING THE RHEEM WARRANTY**

The water heater is not suitable for certain water chemistries. Those chemistries are listed below. If the water heater is connected at any time to a water supply with the following water chemistry, Rheem's warranty will not cover any resultant faults:

### **Water Chemistry**

Saturation Index (SI) < -1.0

Saturation Index (SI) > +0.4

Chloride > 250 mg/L

pH < 6.0

### **Component**

water heater

water heater

water heater

water heater

# SAVE A SERVICE CALL

Check the items below before making a service call. You will be charged for attending to any condition or fault that is not related to manufacture or failure of a part.

## NOT ENOUGH HOT WATER (OR NO HOT WATER)

- **Is the electricity switched on?**

Inspect the isolating switch marked “HOT WATER” or “WATER HEATER” at the switchboard and the isolating switch at the water heater and ensure they are turned on.

Check the circuit breaker marked “HOT WATER” or “WATER HEATER” at the switchboard.

- **Is the alarm light flashing RED on heat pump controller?**

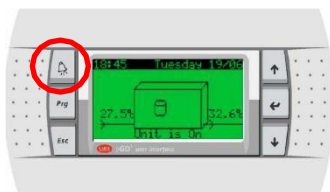

If the alarm light is flashing RED, check the alarm by pressing the alarm button. Phone your nearest Rheem Service Department or Accredited Service Agent (or Service Centre in NZ) to inform about the alarm.

- **Is the timer set?**

If the timer has been set, ensure sufficient time has been allowed to reheat the storage tanks.

- **Are you using more hot water than you think?**

Are outlets (especially the showers) using more hot water than you think? Very often it is not realised the amount of hot water used, particularly when showering. Carefully review the hot water usage. Have your plumber install a flow control valve to each shower outlet to reduce water usage.



- **Heat pump circulator has failed?**

The heat pump will not operate if the heat pump circulator has failed. Refer to “[Heat Pump Is Not Operating](#)” on [page 17](#). Phone your nearest Rheem Service Department or Accredited Service Agent to arrange for an inspection.

- **Water heater size**

Do you have the correct size water heater for your requirements? The sizing guide in the sales literature and on the Rheem website ([www.rheem.com.au](http://www.rheem.com.au) or [www.rheem.co.nz](http://www.rheem.co.nz)) suggest average sizes that may be needed.

### **WATER TOO HOT**

The water heater, during both normal heat pump operation and auxiliary booster operation (when freeze protection is activated, will heat the water to a temperature of 60°C to 65°C. It is recommended to set the auxiliary booster thermostat setting to 60°C.

### **WATER NOT HOT ENOUGH**

You may find that due to heavy hot water usage the water temperature may be lower than normally expected, due to insufficient heating time being allowed. Additional storage or an in series booster may be required to be installed under these circumstances.

### **HEAT PUMP IS NOT OPERATING**

- **When freeze protection is activated– auxiliary boost mode**

If the freeze protection activates, the heat pump will stop operating and the auxiliary water heater, if installed, will operate instead. The total storage tank capacity will be heated to 60°C during these periods. Heating of the water by the heat pump will occur when the freeze protection deactivates.

- **Thermal cut out activated**

Has the thermal cut out for the heat pump compressor activated?

If the thermal cut out has activated, the heat pump will not operate for a period of 20 minutes to 2 hours and display alarm on the control panel. The water heater will make two more attempts to start. If the thermal cut out is tripped again after the third attempt, the system will enter lock out. If connected to a BMS, this will alert the user that the unit is not operating.

To check whether there may be a problem, switch the power to the water heater off and on again at the circuit breaker to the water heater, then open a hot tap and allow to run for ten to fifteen minutes. The heat pump, if working properly, will activate and continue operating to heat the water. Close the hot tap when the heat pump begins to operate.

However, if the heat pump deactivates within five minutes, there may be a problem. Phone your nearest Rheem Service Department or Accredited Service Agent (or Service Centre in NZ) to arrange for an inspection.

- **Incorrect Phase Rotation**

The phase fail relay will open circuit if the heat pump has been wired with incorrect phase rotation or if a phase has failed. Both green and yellow LEDs on the relay will be illuminated if all phases are available and phase rotation is correct.

- **Heat pump circulator has failed**

If the heat pump circulator has failed, the heat pump will not operate. Phone your nearest Rheem Service Department or Accredited Service Agent (or Service Centre in NZ) to arrange for an inspection.

## **HIGH ELECTRICITY BILLS**

With the installation of your new water sourced heat pump water heater, maximum electrical energy savings can be achieved. Should you at any time, feel your energy account is too high, we suggest you check the following points:

- Is the relief valve in the storage tanks running excessively?
- Are outlets (especially the showers) using more hot water than you think? (Refer to **“Not Enough Hot Water”** on **page 16**).
- Is there a leaking hot water pipe, dripping hot water tap, etc? Even a small leak will waste a surprising quantity of hot water and energy. Replace faulty tap washers, and have your plumber rectify any leaking pipe work.
- Consider recent changes to your hot water usage pattern and check if there has been any increase in tariffs since your previous account.
- The heat pump water heater operates at its most efficient at higher cold side water temperatures. Prolonged periods of activation of freeze protection will decrease the efficiency of the system and increase running costs.

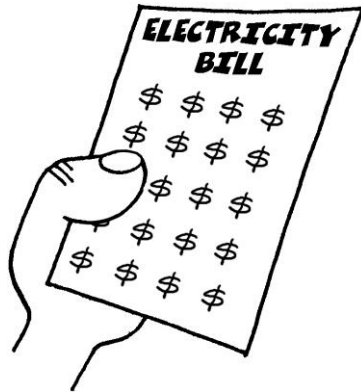

**IF YOU HAVE CHECKED ALL THE FOREGOING AND STILL BELIEVE YOU NEED ASSISTANCE, CALL YOUR NEAREST RHEEM SERVICE DEPARTMENT OR ACCREDITED SERVICE AGENT.**

# INSTALLATION

**THIS WATER HEATER IS FOR INDOOR OR OUTDOOR INSTALLATION.  
THIS WATER HEATER IS NOT SUITABLE FOR POOL HEATING.**

## **INSTALLATION STANDARDS**

The water heater must be installed:

- by a qualified person, and
- in accordance with the installation instructions, and
- in compliance with Standards AS/NZS 3500.4, AS/NZS 3000 and all local codes and regulatory authority requirements.

In New Zealand, the installation must also conform with Clause G12 of the New Zealand Building Code.

## **WATER HEATER APPLICATION**

This water heater is designed for the purpose of heating potable water by simultaneously reducing building chilling load. Its use in an application other than this may shorten its life

If this water heater is to be used where an uninterrupted hot water supply is necessary for the application or business, then there should be redundancy within the hot water system design. This should ensure the continuity of hot water supply in the event that this water heater was to become inoperable for any reason. We recommend you provide advice to the system owner about their needs and building backup redundancy into the hot water supply system.

## **COMPONENTS**

The heat pump water heater system is modular and comprises three main components: the heat pump water heater, storage tanks, and primary circulators. An auxiliary booster and circulator may also be employed as part of the system. The water heater must not be operated until all components are assembled.

**Do not tilt the heat pump more than 45° from the vertical.** This will unsettle the refrigerant gas and compressor lubricating oil. If the heat pump has been tilted more than 45° from the vertical during handling, it will need one hour to settle before the power to the water heater can be switched on, otherwise damage to the compressor may result.

## **INDOOR INSTALLATION**

To comply with AS1677.2, the minimum room size permissible is 5.6m<sup>3</sup> per 20kW heat pump and 15.34 m<sup>3</sup> per 45kW heat pump.

# INSTALLATION

## **WATER HEATER LOCATION**

All models are designed to be installed outdoors or indoors, as long as the room meets the volume requirements stated above.

It is advisable to install the water heater away from bedroom or living room windows as the system can generate a noise of 59dBA (at 3 metres from the water heater) whilst operating.

It is recommended the water heater be installed at ground or floor level. Stacked units with base unit at ground or floor level is acceptable from a servicing perspective.

The water heater must stand vertically upright.

Clearance must be allowed for servicing of the water heater. The water heater must be accessible without the use of a ladder or scaffold.

You must be able to read the information on the rating plate. Remember you may have to remove the entire water heater later for servicing.

A clearance of 850 mm is required from the side of water connections and the front of the heat pump.

## **SAFE TRAY**

Where damage to property can occur in the event of the water heater leaking or condensate forming under the drain tray, the water heater must be installed in a safe tray or be suitably banded. Construction, installation and draining of a safe tray must comply with AS/NZS 3500.4 and all local codes and regulatory authority requirements.

# INSTALLATION

## MAINS WATER SUPPLY

Where the mains water supply pressure exceeds that shown in the table below, an approved pressure limiting valve is required and should be fitted as shown in the installation diagram (refer to diagram on [page 38](#)).

Relief valve setting (VE/610 Series storage tanks)	1000 kPa
Expansion control valve setting *	850 kPa
Relief valve setting (SS/RT Series storage tanks)	850kPa
Expansion control valve setting *	700 kPa
<b>Max-supply pressure (VE/610 Series storage tanks)</b>	
Without expansion control valve	800 kPa
With expansion control valve	680 kPa
<b>Max-supply pressure (SS/RT Series storage tanks)</b>	
Without expansion control valve	680 kPa
With expansion control valve	550 kPa
<b>Max-supply pressure (SS/6N0 Induro Series storage tanks)</b>	
Without expansion control valve	800 kPa
With expansion control valve	680 kPa

\* Expansion control valve not supplied with the water heater.



## TANK WATER SUPPLY

If the storage tank is supplied with water from a tank supply and a pressure pump system is not installed, then the bottom of the supply tank must be at least 1 m above the highest point of the hot water plumbing system, including the storage tank. Care must be taken to avoid air locks. The cold water line to the storage tank should be adequately sized and fitted with a full flow gate valve or ball valve.

## HOT WATER DELIVERY

This water heater can deliver water at temperatures which can cause scalding.

It is necessary and we recommend that a temperature limiting device be fitted between the storage tanks and the hot water outlets in any ablation area such as a bathroom or ensuite, to reduce the risk of scalding. The installing plumber may have a legal obligation to ensure the installation of this water heater system meets the delivery water temperature requirements of AS/NZS 3500.4 so that scalding water temperatures are not delivered to a bathroom, ensuite or other ablation area.

Where a temperature limiting device is installed adjacent to the storage tanks, the cold water line to the temperature limiting device can be branched off the cold water line either before or after the isolation valve, pressure limiting valve and non return valve to the water heater system. If an expansion control valve is required, it must always be installed after the non return valve and be the last valve prior to the storage tanks.

# INSTALLATION

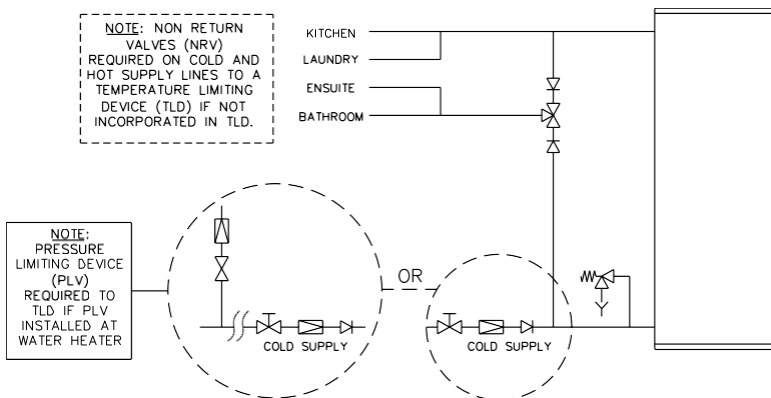

## Two Temperature Zones Using a Temperature Limiting Device

If a pressure limiting valve is installed on the cold water line to the water heater system and the cold water line to a temperature limiting device branches off before this valve or from another cold water line in the premises, then a pressure limiting valve of an equal pressure setting may be required prior to the temperature limiting device.

## CIRCULATED HOT WATER FLOW AND RETURN SYSTEM

This heat pump water heater may be installed as part of a circulated hot water flow and return system in a building as long as a temperature boosting water heater is not installed downstream of the heat pump.

If a temperature boosting water heater is installed the circulated hot water flow and return system must return to the inlet of the temperature boosting water heater, and not the heat pump, to avoid potential nuisance tripping.

## Temperature Limiting Device

A temperature limiting device cannot be installed in circulated hot water flow and return pipe work unless the device is designed for such application, such as Rheem Guardian. The tempered water from a temperature limiting device cannot be circulated. Where a circulated hot water flow and return system is required in a building, a temperature limiting device can only be installed on a dead leg, branching off the circulated hot water flow and return pipe.

# INSTALLATION

If circulated tempered water were to be returned back to the water heater, depending on the location of the return line connection on the water supply line to the water heater, then either:

- water will be supplied to the cold water inlet of the temperature limiting device at a temperature exceeding the maximum recommended water supply temperature, or
- when the hot taps are closed no water will be supplied to the cold water inlet of the temperature limiting device whilst hot water will continue to be supplied to the hot water inlet of the temperature limiting device.

These conditions may result in either water at a temperature exceeding the requirements of AS/NZS 3500.4 being delivered to the hot water outlets in the ablation areas, or the device closing completely and not delivering water at all, or the device failing. Under either condition, the operation and performance of the device cannot be guaranteed.

## **INSULATION**

To minimise heat loss and provide protection from freezing, the cold water line to and the hot water line from the heat pump water heater must be insulated in accordance with the requirements of AS/NZS 3500.4. The insulation must be weatherproof and UV resistant if exposed.

## **SADDLING - PIPE WORK**

To prevent damage to the heat pump and storage tanks when attaching pipe clips or saddles to the water heater jacket, we recommend the use of self-drilling screws with a maximum length of 12 mm. Should pre drilling be required, extreme caution must be observed when penetrating the jacket of the water heater.

**Avoid drilling or saddling in the vicinity of the refrigerant or plumbing circuits. These circuits are in close proximity to the jacket and rupturing of the circuit may occur.**

**Note: If the heat pump is damaged as a result of attaching pipe clips or saddling to the jacket, any resultant faults will not be covered by the Rheem warranty.**

# INSTALLATION

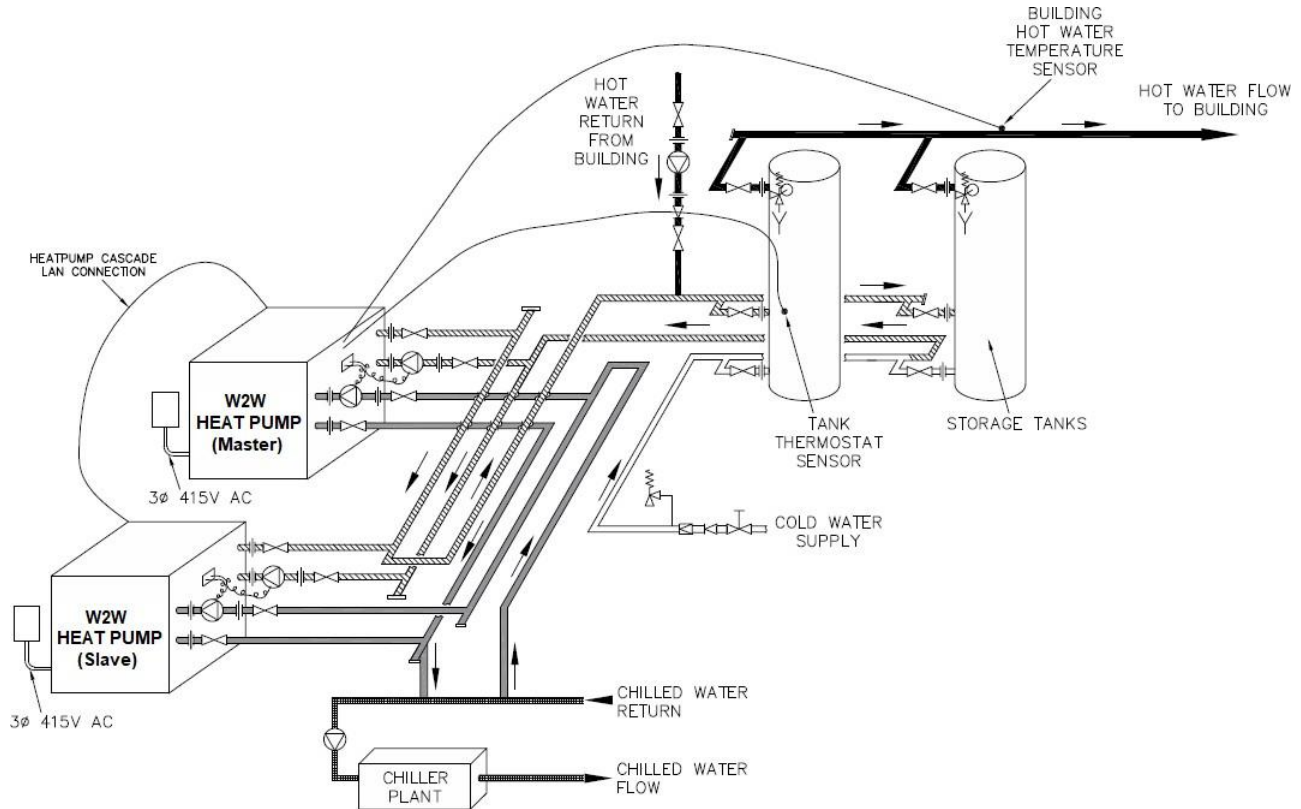

**Typical Installation with Recirculation**

# INSTALLATION

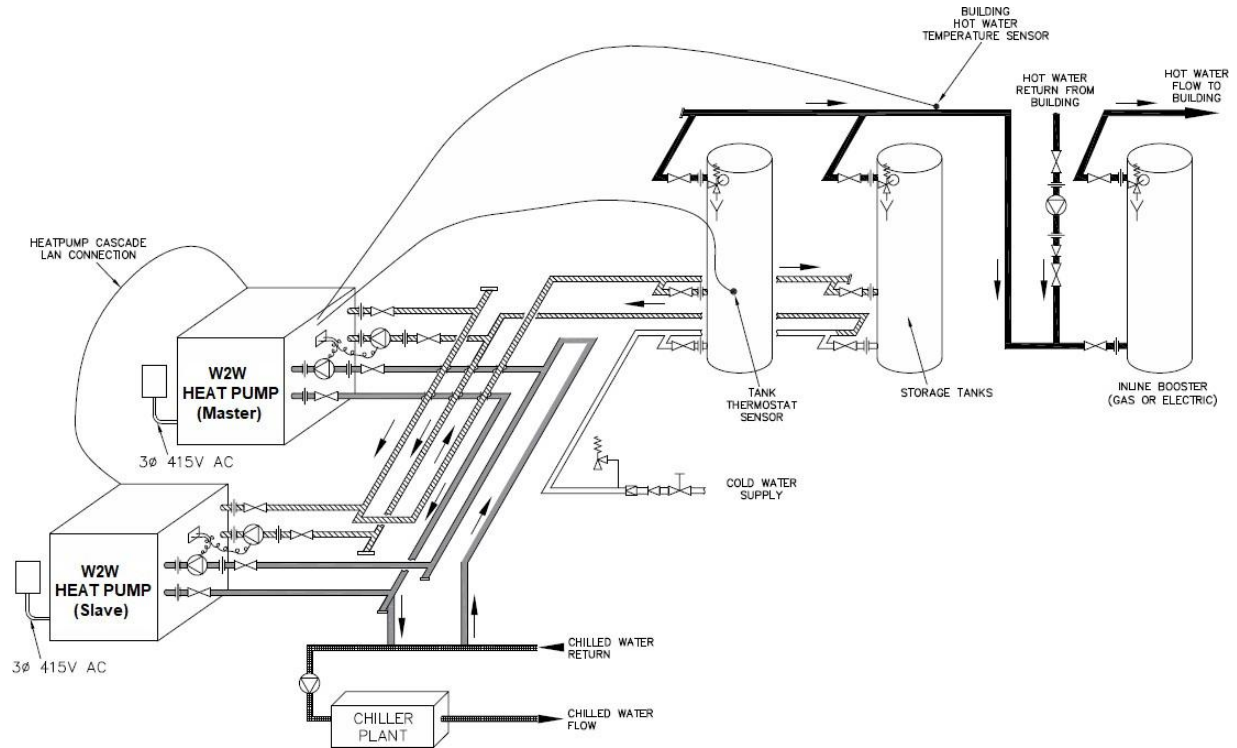

**Typical Installation with Inline Auxiliary Boost**

# INSTALLATION

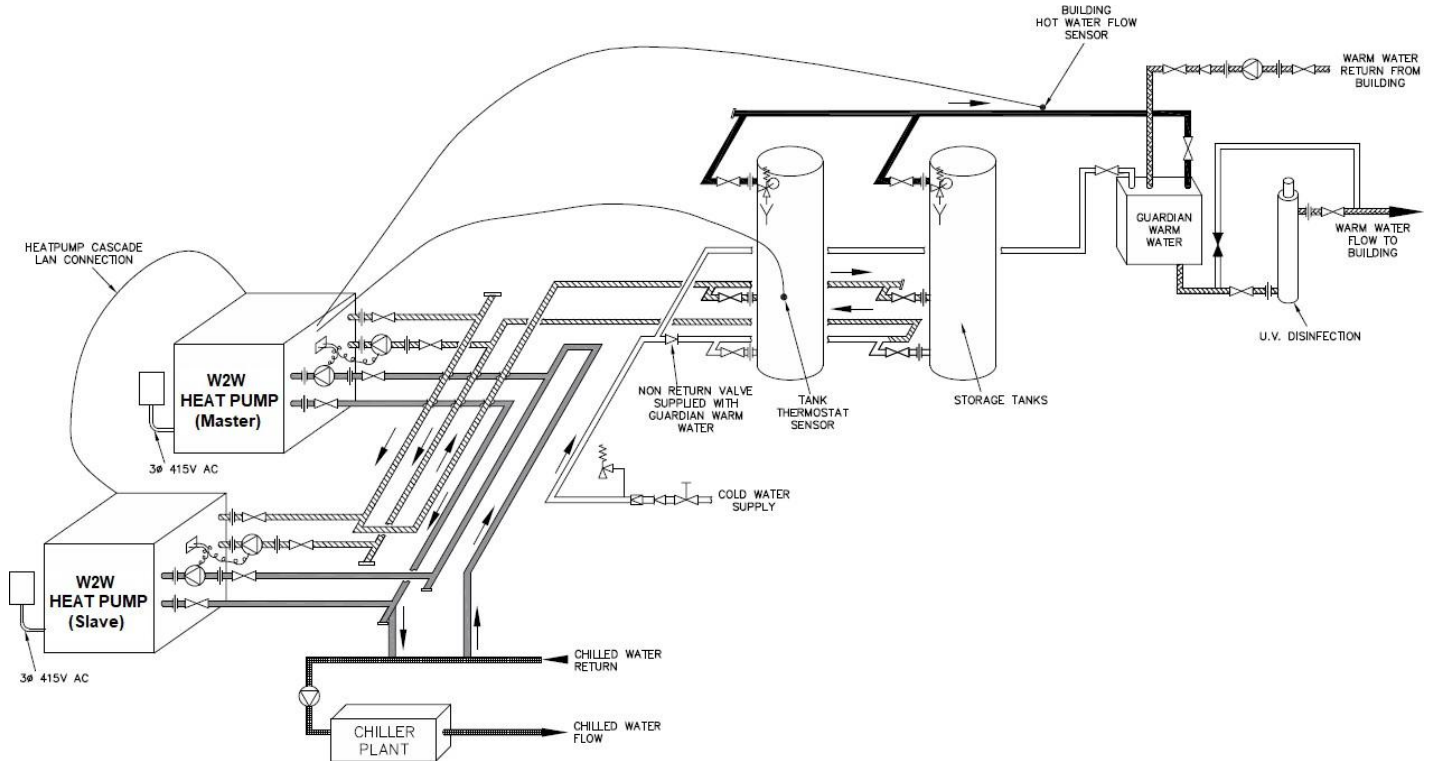

Typical Installation with Rheem Guardian Warm Water System

# INSTALLATION

Dimensions and Technical Data - RHEEM W2W Model 20kW 95402000

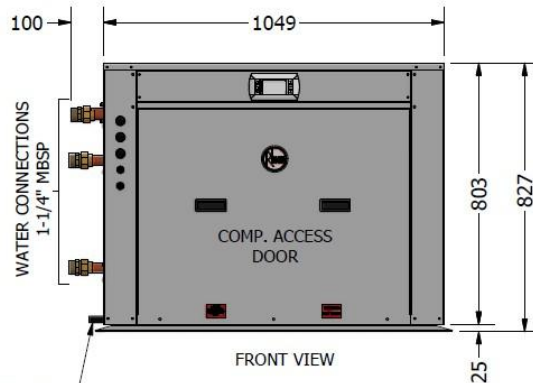
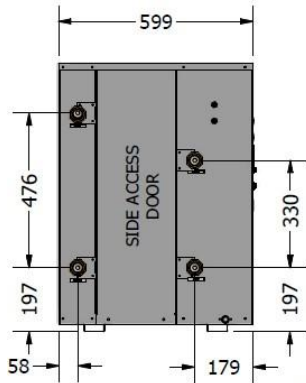
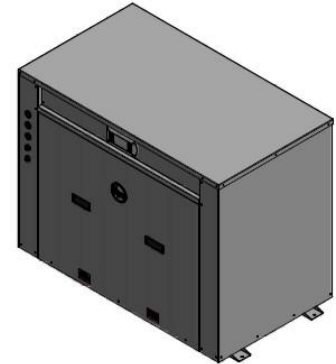
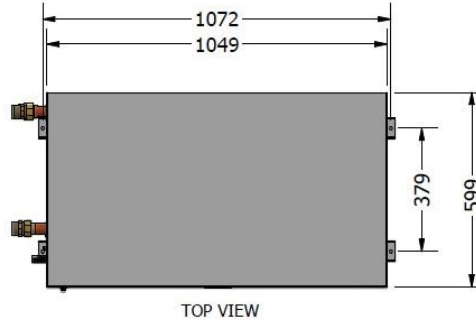

CONDENSATE DRAIN Ø20mm

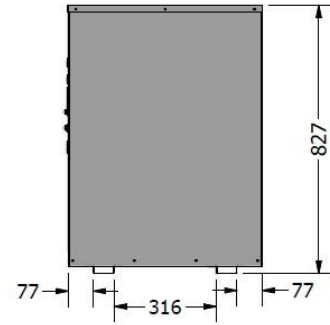

# INSTALLATION

## Dimensions and Technical Data - RHEEM W2W Model 45kW 95404500

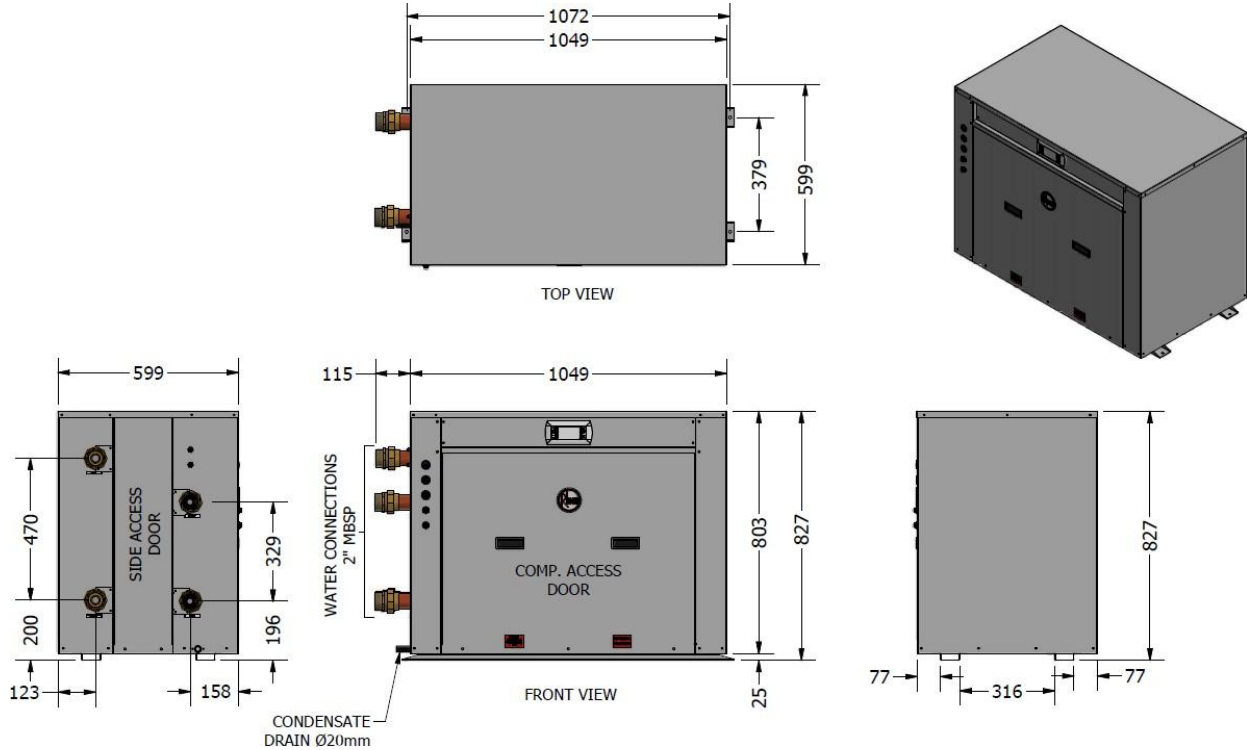

# INSTALLATION

## Dimensions and Technical Data - RHEEM W2W Stackable Model 20kW 9540200S

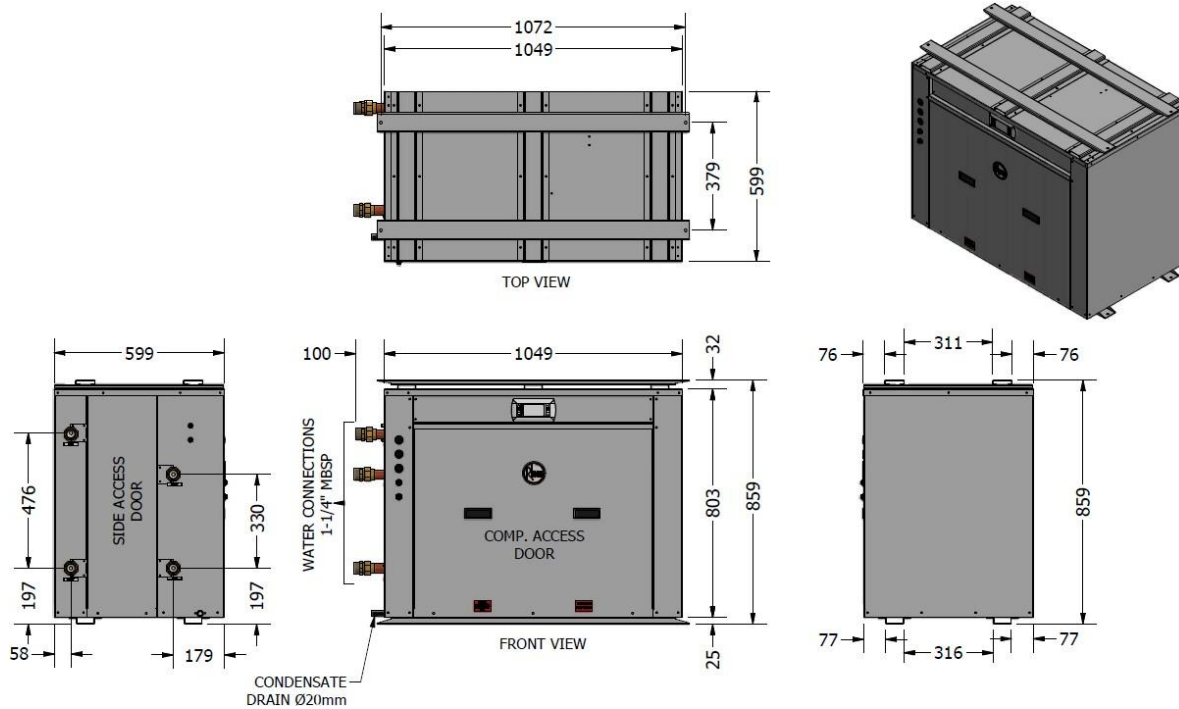

# INSTALLATION

## Dimensions and Technical Data - RHEEM W2W Stackable Model 45kW 9540450S

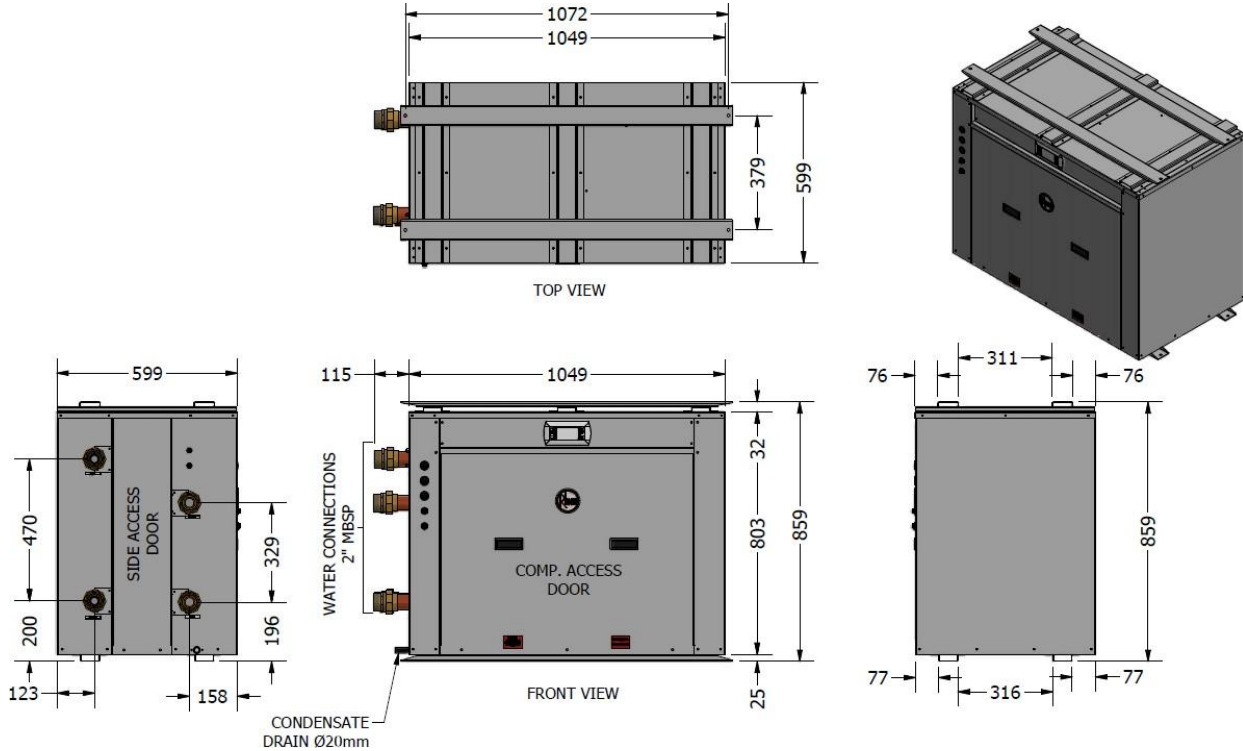

## CLEARANCES- WATER TO WATER HEAT PUMP MODELS

Sides	Unit	All Water to Water Heat Pumps
Front	mm	850
Back	mm	Nil
Water Connections Side	mm	850
RHS Side	mm	Nil
Top (clearance above unit required for service personnel to stand)	mm	Nil

## HEAT PUMP AND TANK ASSEMBLY

### HEAT PUMP AND STORAGE TANKS

The heat pump water heater system is modular and comprises three main components: the heat pump water heater, storage tanks, and primary circulators. An auxiliary booster and circulator may also be employed as part of the system. The water heater must not be operated until all components are assembled.

### HEAT PUMP

Locate the heat pump(s) in the appropriate position observing the required clearances for operation and servicing. **Refer to page 31.**

#### Indoor Installations

To comply with AS1677.2, the minimum room size permissible in relation to the quantity of refrigerant in the water heater, is 5.6m<sup>3</sup> for per 20kW heat pump and 15.34 m<sup>3</sup> for per 45kW heat pump.

# HEAT PUMP AND TANK ASSEMBLY

## Stackable Models Installations

Stackable models can be stacked two high to reduce footprint as shown in the diagram below. Items 3 to 6 in the table below are supplied with a stackable heat pump model.

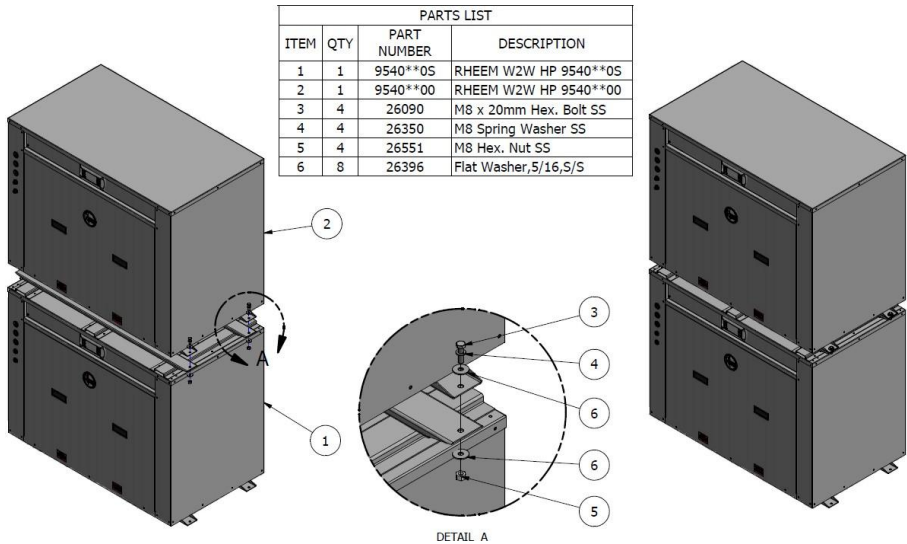

**Note:** Top unit can be 9540\*\*00.

## STORAGE TANKS

Rheem Commercial storage tanks are employed to store the hot water generated by the heat pump. The tanks must be manifolded using the Equa-Flow<sup>®</sup> manifold system to ensure even distribution of the stored energy. Up to ten tanks can be manifolded together in a single bank. More than one bank can be used. Follow the diagram on [page 36](#) when manifolding the tanks.

Refer to the installation instructions supplied with the storage tanks for specific information relating to the installation of the storage tanks.

## PRIMARY CIRCULATORS

Each side (cold and hot) of heat pump requires a primary circulator to ensure the correct flow rate and temperature rise is achieved. Where more than one heat pump is installed the common manifold must be installed using the Equa-Flow<sup>®</sup> manifold system and must be sized to accommodate the total flow of all the primary pumps running simultaneously.

# HEAT PUMP AND TANK ASSEMBLY

Refer to table below for minimum (ID) pipe sizing.

W2W HP 20kW					W2W HP 45kW				
Hot Side					Hot Side				
No. of Heat Pumps in Parallel	1	2	3	4	No. of Heat Pumps in Parallel	1	2	3	4
Pump	Grundfos CM3-2				Pump	Grundfos CM10-1			
Branch Size (mm)	40				Branch Size (mm)	50			
Header Size (mm)	40	50	65	80	Header Size (mm)	50	80	100	100
Cold Side					Cold Side				
No. of Heat Pumps in Parallel	1	2	3	4	No. of Heat Pumps in Parallel	1	2	3	4
Pump	Grundfos CM3-2				Pump	Grundfos CM10-1			
Branch Size (mm)	40				Branch Size (mm)	50			
Header Size (mm)	40	50	65	80	Header Size (mm)	50	80	100	100

The designed primary pump per 20kW model is Grundfos CM3-2 and per 45kW model is CM10-1. Refer to installation manuals supplied with pumps. If another pump has been supplied, consult Rheem before continuing with the installation.

Header pipe sizing is based on one pump per heat pump with a total length of 20m of primary flow and return piping and 20 x 90° bends, excluding Equa-flow manifolds on storage tanks and heat pumps at 1.2m/sec velocity, with a cold side water entering temperature not exceeding 35°C. If this specification is exceeded consult Rheem before continuing with the installation.

Multiple heat pumps **MUST** be installed using Equa-Flow® principles to ensure the demand on each heat pump (or storage tank) in the bank is the same as any other. To achieve this, the following is necessary:

1. The **inlet** manifolds must be designed to balance the flow to each heat pump i.e. each branch line must be the same diameter and length.
2. The **outlet** manifolds must be designed to balance the flow from each heat pump i.e. each branch line must be the same diameter and length.
3. The first heat pump in must be the last heat pump out.

Note: Inlet and outlet water isolation valves **MUST** be installed at each heat pump to enable each heat pump to be individually isolated for servicing. The inlet isolation valves **MUST** be installed before the pumps to also enable the pumps to be isolated for servicing.

# HEAT PUMP AND TANK ASSEMBLY

## AUXILIARY WATER HEATER

It may be necessary to install an auxiliary water heater under the following conditions:

- If poor flow rate is sensed or the cold side outlet temperature or hot side outlet temperature is likely to drop below 5°C during periods when heating may be required.
- To ensure sufficient hot water is available for higher than expected peak conditions.
- If higher temperature water is required for certain applications, eg commercial laundry or kitchen.

The configuration of the auxiliary water heating plant can vary depending on the requirements of the individual installation.

**Operation at Activation of Freeze Protection Only** - Where the auxiliary water heater is required to be activated if the heat pump cannot operate due to freeze protection, the heat pump can activate the auxiliary heater or pump. There are many configurations depending on system design. Consult the Application Guide for details on the auxiliary boost function designed for this system.

**In Line Boosting Only** - Where the auxiliary water heater is required to ensure sufficient hot water is available for periods after the main peak or to boost the temperature of the water produced by the heat pump for other purposes (eg high temperature for kitchen and laundry use), auxiliary water heater(s) must be installed in series with the storage tanks. ie, the hot water outlet from the storage tanks must feed into the inlet of the auxiliary water heater(s).

**Note:** Where RT storage tanks are used, boosting in the top portion of the storage tank is equivalent to boosting in series.

Where multiple auxiliary water heaters are required to be manifolded together, these must be manifolded using the Equa-Flow® manifold system and the manifold in-series with the storage tanks. Refer to **page 36**.

This arrangement can also be adapted to include recirculation heat loss make up and / or freeze protection activation heating. Refer to Application Guide for options.

# MANIFOLD INSTALLATIONS

The Rheem commercial heat pump water heater is designed to be installed with storage tanks on a single manifold, or multiple manifolds if required, using the Rheem Equa-Flow® manifold system. The Equa-Flow principle will function with water heaters in line, around a corner or in rows back to back (refer to the diagrams on **pages 36 to 37**).

The cold water, primary flow and hot water manifolds must be designed to balance the flow from each water heater and storage tank. To achieve this, there are basic installation requirements and principles which must be followed:

1. The maximum number of storage tanks in a bank should be 10, however several banks of storage tanks can be installed.
2. The hot water line from the manifold must leave from the opposite end to which the cold water line enters the manifold.
3. The storage tanks must be of the same model.
4. The cold water line, cold and hot headers and hot water line must be sized to meet the requirements of both AS/NZS 3500.4 and the application.
5. A non-return valve, isolation valve and if required a pressure limiting valve and expansion control valve, must be installed on the cold water line to the system.
6. A full flow gate valve or ball valve (not a stop tap, as used on a single water heater installation) must be installed on both the cold water branch and hot water branch of each water heater and storage tank.
7. Non return valves or pressure limiting valves **MUST NOT** be installed on the branch lines to the water heaters or storage tanks.
8. All fittings, valves and branch lines must be matched sets all the way along the manifold.
9. Sufficient space must be left to enable access, servicing or removal of any water heater or storage tank.
10. The temperature pressure relief valve drain line from each storage tank can terminate at a common tundish (funnel) with a visible air break at each drain discharge point.

# MANIFOLD INSTALLATIONS

## Manifold Arrangement

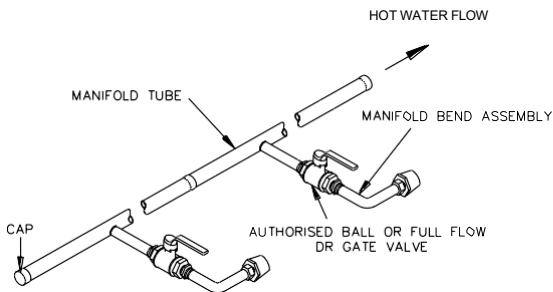

**Hot Manifold Assembly**

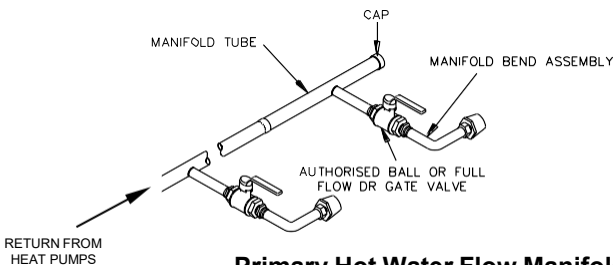

**Primary Hot Water Flow Manifold Assembly**

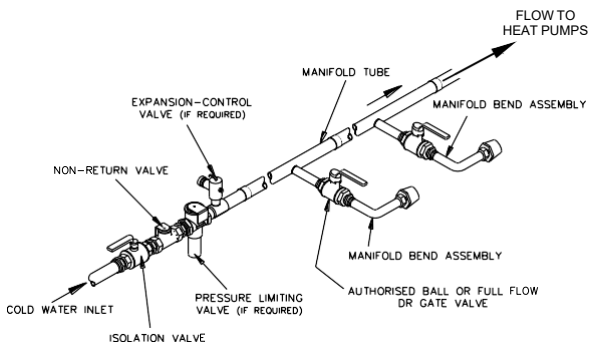

**Cold Manifold Assembly**

# MANIFOLD INSTALLATIONS

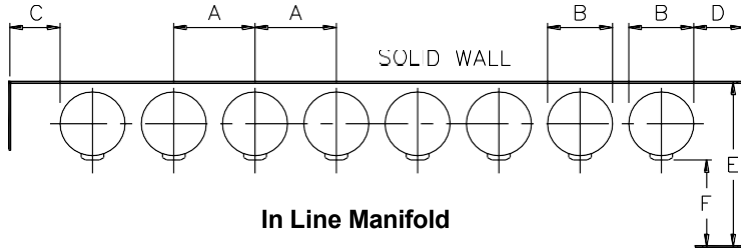

**In Line Manifold**

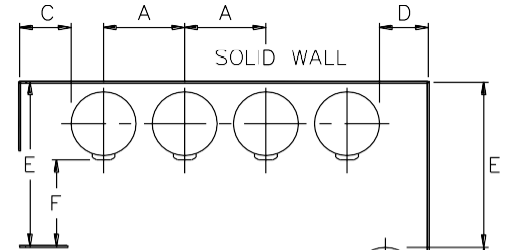

**Angle Manifold**

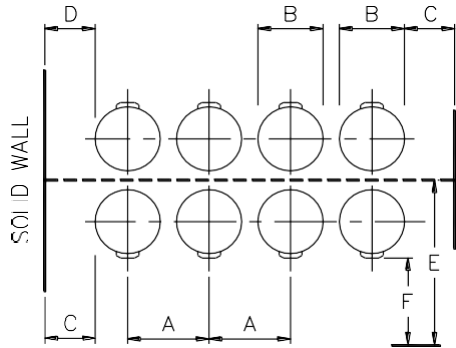

**Back to Back Manifold**

<b>NOTES:</b>						
Minimum recommended space between wall and back of water heater is 100 mm.						
A minimum of 900 mm (E* & F*) should be left in front of the water heater for access, servicing and water heater removal.						
<b>Installation Layout Minimum Dimensions</b>						
Model	A	B	C	D	E*	F*
610 430	935	685	300	100	1685	900
RT1000	1250	1000	300	100	2100	1000
RT2000	1550	1300	300	100	2700	1300
RT3000	1700	1450	300	100	3000	1450
RT4000	1850	1600	300	100	3300	1600
RT5000	2050	1800	300	100	3700	1800

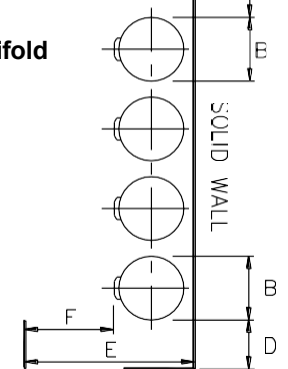

## INSTALLATION DIMENSIONS – MULTIPLE RHEEM STORAGE TANKS

# CONNECTIONS – PLUMBING

## CONNECTION SIZES

Model	20kW	45kW
Heat pump water heater inlet connection	R1½ BSPM	R2 BSPM
Heat pump water heater outlet connection	R1½ BSPM	R2 BSPM
Condensate drain connection	20mm O.D	

All plumbing work must be carried out by a qualified person and in accordance with the Plumbing Standard AS/NZS 3500.4 and local authority requirements.

## WATER INLET AND OUTLET

The pipe work must be cleared of foreign matter before connection and purged before attempting to operate the water heater. All olive compression fittings must use brass or copper olives. Use thread sealing tape or approved thread sealant on all screwed fittings.

An isolation valve and non-return valve must be installed on the cold water line to the water heater system. An acceptable arrangement is shown in the diagram. Refer also to “Hot Water Delivery” on [page 21](#) and to “Mains Water Supply” on [page 21](#).

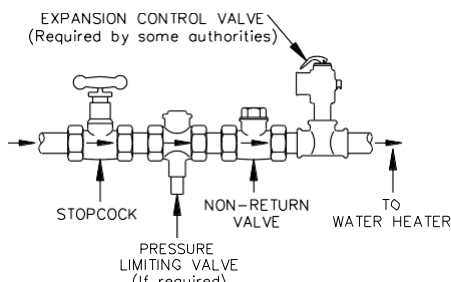

Disconnection unions are provided at the cold side and hot side water inlets and outlets on the water heater to allow for disconnection of the water heater. Use a spanner on the back nut when tightening unions to prevent the pipe from rotating or twisting within the heat pump.

## PIPE SIZES

To achieve true mains pressure operation, the cold water line to the storage tanks should be the same size or bigger than the hot water line from the storage tanks.

The pipe sizing for hot water supply systems should be carried out by persons competent to do so, choosing the most suitable pipe size for each individual application. Reference to the technical specifications of the water heater and local regulatory authority requirements must be made.

Refer to the table on [page 33](#) for correct primary flow and return pipe sizing.

# CONNECTIONS - PLUMBING

## RELIEF VALVE

The heat pump is supplied with an integral pressure relief valve located on the inside of the heat pump cabinet and will discharge into the tray of the heat pump. Refer to Condensate Drain on [page 39](#) for drainage instructions.

## EXPANSION CONTROL VALVE

Local regulations may make it mandatory to install an expansion control valve (ECV) in the cold water line to the water heater system. In other areas, an ECV is not required unless the saturation index is greater than +0.4 (refer to "Water Supplies" on [page 14](#)). However, an ECV may be needed in a corrosive water area where there are sufficient quantities of silica dissolved in the water.

The expansion control valve must always be installed after the non return valve and be the last valve installed prior to the water heater system (refer to diagram on [page 35](#)).

## EXPANSION CONTROL VALVE DRAIN

A copper drain line must be fitted to the relief valve to carry the discharge clear of the water heater. Connect the drain line to the relief valve using a disconnection union. The pipe work from the relief valve to the drain should be as short as possible and fall all the way from the water heater with no restrictions. It should have no more than three right angle bends in it. Use DN15 pipe.

The outlet of the drain line must be in such a position that flow out of the pipe can be easily seen (refer to AS/NZS 3500.4) - but arranged so hot water discharge will not cause injury, damage or nuisance. The drain line must discharge at an outlet or air break not more than 9 metres from the relief valve.

In locations where water pipes are prone to freezing, the drain line must be insulated and not exceed 300 mm in length. In this instance, the drain line is to discharge into a tundish through an air gap of between 75 mm and 150 mm.

## CONDENSATE DRAIN

A drain line may be fitted to the condensate drains to carry the discharge clear of the water heater. The drain line can be extended using 20 mm O.D. rigid hose or conduit. Where installed externally, the drain line pipe work must be UV resistant or protected from sunlight. The outlet of the drain line must be in such a position that flow out of the pipe can be easily seen - but arranged so water discharge will not cause damage or nuisance.

**The condensate drain must not be connected to the pressure relief or expansion control valve drain line but may discharge at the same point.**

# CONNECTIONS – ELECTRICAL

**The power supply to the water heater must not be switched on until the water heater is filled with water and a satisfactory megger reading is obtained.**

## MEGGER READING

When a megger test is conducted on this water heater, then the following should be noted.

**⚠ Warning:** This water heater contains electronic equipment and 500 V insulation tests must only be conducted between actives and earth and between neutral and earth. An active to neutral test WILL damage the electronics.

**An insulation test result of above 1 MΩ should be obtained for this water heater.**

## ELECTRICAL CONNECTION

All electrical work and permanent wiring must be carried out by a qualified person and in accordance with the Wiring Rules AS/NZS 3000 and local authority requirements.

### Heat Pump

The heat pump water heater must be directly connected to a 415 V AC 50 Hz mains power supply. The heat pump must be on its own circuit with an isolating switch installed at the switchboard. A secondary isolating switch must be installed within reach of the water heater.

A conduit is required for the electrical cable to the heat pump water heater. The conduit is to be connected to the unit with a 20mm terminator. Holes are provided on the electrical panel for cabling. Connect the power supply and earth wires directly to the terminal block, ensuring there are no excess wire loops inside the electrical enclosure. Correct phase connection is required.

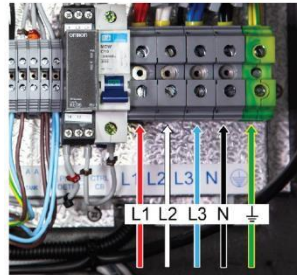

### Electrical Data Table

Model	20kW	45kW
<b>Electrical Connection</b>	3 Phase / 415 Volts / 50 Hz	
<b>Max Current per Phase (running, incl pumps)</b>	13.96 A	29.94A
<b>Minimum Circuit Size (per phase)</b>	20A	40A

## Hot Side and Cold Side Pumps

The power to the hot side pump and cold side pump for each heat pump is supplied from the water heater (heat pump enclosure). Connect the active, neutral and earth wire to each pump terminals as shown in the diagram inside the pump cover and to the terminals located within the heat pump electrical enclosure.

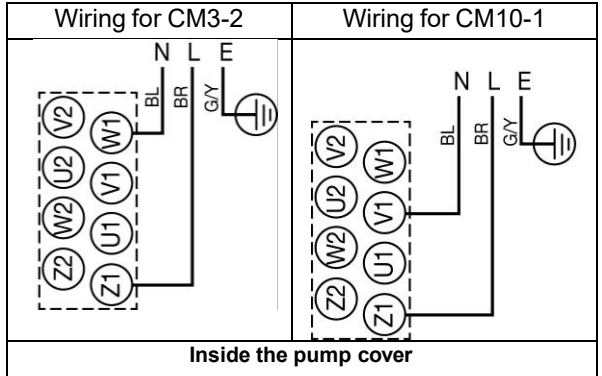

A 20 mm conduit is required for the electrical cable between the water heater and each pump. The conduit is to be connected to the water heater with a 20 mm terminator.

Holes are provided on the electrical panel for cabling.

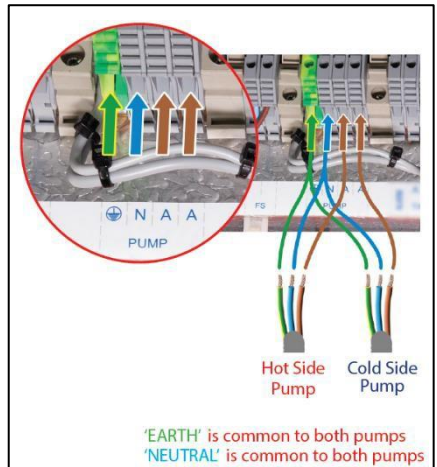
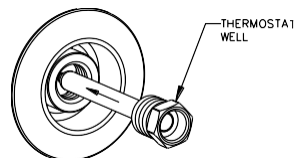

Photo inside the heat pump enclosure

## Tank Sensor Installation

Connect one of the supplied temperature sensors to the connection terminal on the heat pump marked “Tank Sensor”.

- Run out the sensor to the nearest storage tank.



- For 610 series tanks, a thermostat well is supplied within each tank.
- For RT series tanks, a thermostat well is supplied which needs to be fitted to the fitting (2<sup>nd</sup> from the bottom) as shown.

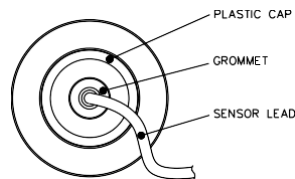
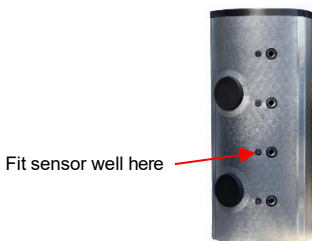

- For 610 series tanks, remove the plastic cover from the fitting located 90° from the water connections on the storage tank, but do not discard.
- Make a small hole in the centre of the plastic cap and thread the sensor through the hole.
- Insert the sensor all the way into the thermostat well and fit the plastic cap back onto the storage tank.
- To prevent the sensor dislodging from the well, screw the cable to the tank jacket using a cable clamp.
- Cable tie the sensor lead, curling up and tying off any excess lead.

## Building Flow Temperature Sensor Installation

- Connect the 2<sup>nd</sup> temperature sensor to the connection terminal on the heat pump marked “Building Flow Sensor”.
- Run out the sensor to the building flow pipe.
- Fit a thermostat well (not supplied) in the pipe ensuring the end of the sensor is in the flow of water. To prevent the sensor dislodging from the well, secure the sensor to the insulation using a cable tie. Alternatively, clamp the sensor to the outside of the pipe using a pipe clamp prior to the insulation being fitted.

**Note:** For multiple heat pump installation, the preferred method is to interconnect the heat pumps (up to 4 maximum) via LAN cables, available as an accessory (part number: 17534).

In this case, only one tank sensor and building flow temperature sensor is required, which are connected to the heat pump designated as the Master.

Alternatively, each heat pump can operate independently in which case each tank sensor and building flow temperature sensor must be connected and fitted as described above.

# Auxiliary Boost Element

Depending on the installation, an auxiliary boost element may be supplied with an RT series storage tank.

If a single auxiliary boost element is supplied by Rheem, remove bridging wire connected at the terminals as shown in the as 'Bridging Wire' behind the element controller cover and connect the 'Bridging Wire' terminals of the element to the voltage free terminal marked 'VF / VF' in the heat pump enclosure to control the operation of the boost element. Wiring is not polarity sensitive. Refer to the diagram below and photo on next page.

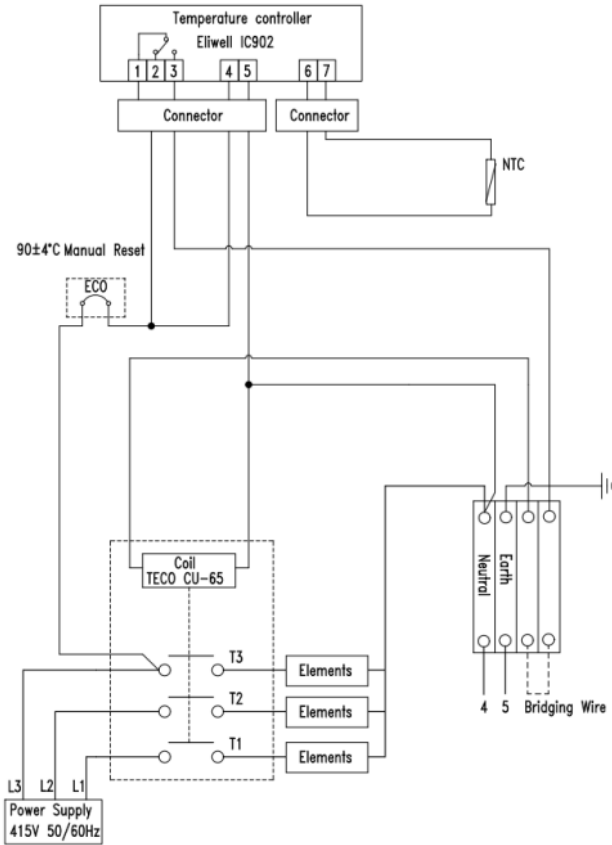

**Electric Heating Unit – Wiring Diagram**

# CONNECTIONS - ELECTRICAL



**Picture of heat pump terminal strip showing VF connections**

Where multiple auxiliary boost elements are required, and the number of auxiliary boost elements matches the number of heat pumps, each element may be interlocked with an individual heat pump directly using the method described above. In this case, the heat pumps should operate independently and each have their own tank and building flow temperature sensor connected.

Where the number of auxiliary boost does not match the number of heat pumps or the heat pumps are connected in a Master/Slave arrangement using LAN cables (refer to [page 45](#)), then the heat pumps must be connected via LAN cables and control of the auxiliary boost elements will be via the Master heat pump using an intermediary relay arrangement. Refer to Application Guide for more detail.

## **Auxiliary Boost Heater (external to storage tank)**

Depending on the installation, an auxiliary heater and/or boost pump may be supplied. Refer to Application Guide for auxiliary boost options.

In the heat pump enclosure, terminals marked “SA”, “N” and “GND” provide 240V to control the auxiliary heater and/or auxiliary pump or multiple boost elements depending on the system design. Maximum current is 1A. Refer to Application Guide for further information to connect auxiliary boost heater.

**Note:** Where multiple heat pumps are required, the heat pumps must be connected in a Master/Slave arrangement using LAN cables (refer to [page 45](#)), and control of the auxiliary boost heaters will be via the Master heat pump. Refer to Application Guide for more details.

# CONNECTIONS - ELECTRICAL

## Multiple Heat Pump Installation

Up to four heat pumps can be interconnected by daisy chaining the LAN cables for operation as shown below. LAN cable is available as an accessory (part number: 17534).

### Step 1:

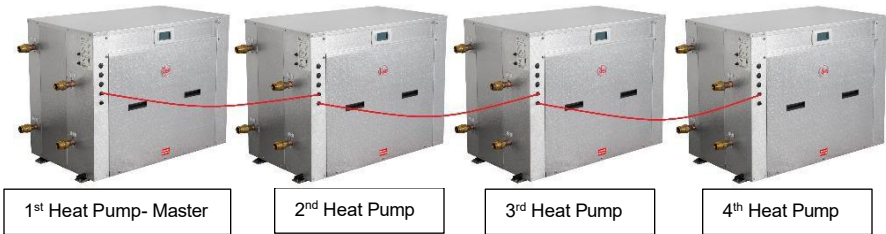

Interconnect the heat pumps as shown above by using the LAN cables. Determine the 1<sup>st</sup> heat pump as Master. Route the cables neatly to prevent damage and trip hazards. Do not route across access panels.

Note: Any of the two LAN connections will be acceptable.

### Step 2:

In 2<sup>nd</sup> heat pump enclosure: Connect “DI3” with “DIC1”. Connect “DIC1” with the existing wire as shown in the picture.

Note: Terminal plug can be removed for ease of making connections by pulling downwards as shown in the picture.



# CONNECTIONS - ELECTRICAL

In 3<sup>rd</sup> heat pump enclosure:  
Connect "DI4" with "DIC1".  
Connect "DIC1" with the existing  
wire as shown in the picture.

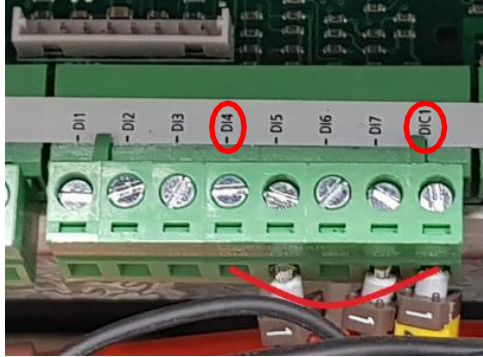

In 4<sup>th</sup> heat pump enclosure:  
Connect "DI3" with "DI4" and  
"DIC1". Connect "DIC1" with the  
existing wire as shown in the  
picture.

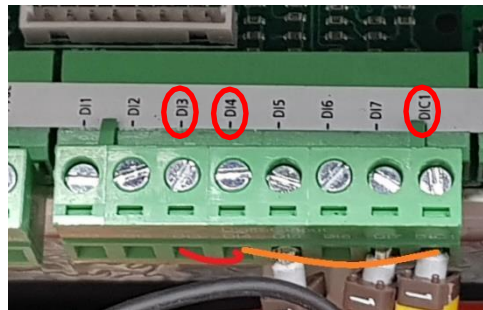

## Note

1. Tank temperature sensor for the Master heat pump must be connected, otherwise the heat pumps will not operate due to fault. There is no need to connect tank temperature sensors for Slave heat pumps.
2. Building temperature sensor for the Master heat pump must be connected. There is no need to connect building temperature sensors for Slave heat pumps.
3. Ignore the values for tank and building temperature sensors on the display of Slave heat pumps as these are not connected.

# CONNECTIONS - ELECTRICAL

## **Building Management Systems (BMS/BAS)**

Each water heater can be connected to a BMS or BAS system via interface cards (Modbus RS485 or BACnet MS-TP or BACnet TCP/IP Ethernet), available as an accessory.

Based on site requirement, a suitable interface card needs to be connected to Rheem IQ control panel as shown in the diagram below.



- If the system is comprised of single or multiple standalone heat pumps, each heat pump will have its own BMS card.

Insert the BMS card into the connector for each heat pump, taking care that the card is firmly placed as shown in red circle.

- If the system is comprised of multiple heat pumps for Master/Slave operation, only master heat pump will have a BMS card and the slave heat pumps will be connected via LAN cables.

Follow the instruction on **page 45** for Interconnecting Multiple Heat Pumps from step 1 to step 2.

Insert the BMS card into the connector for Master heat pump, taking care that the card is firmly placed as shown in red circle.

# 20KW HEAT PUMP WIRING DIAGRAM

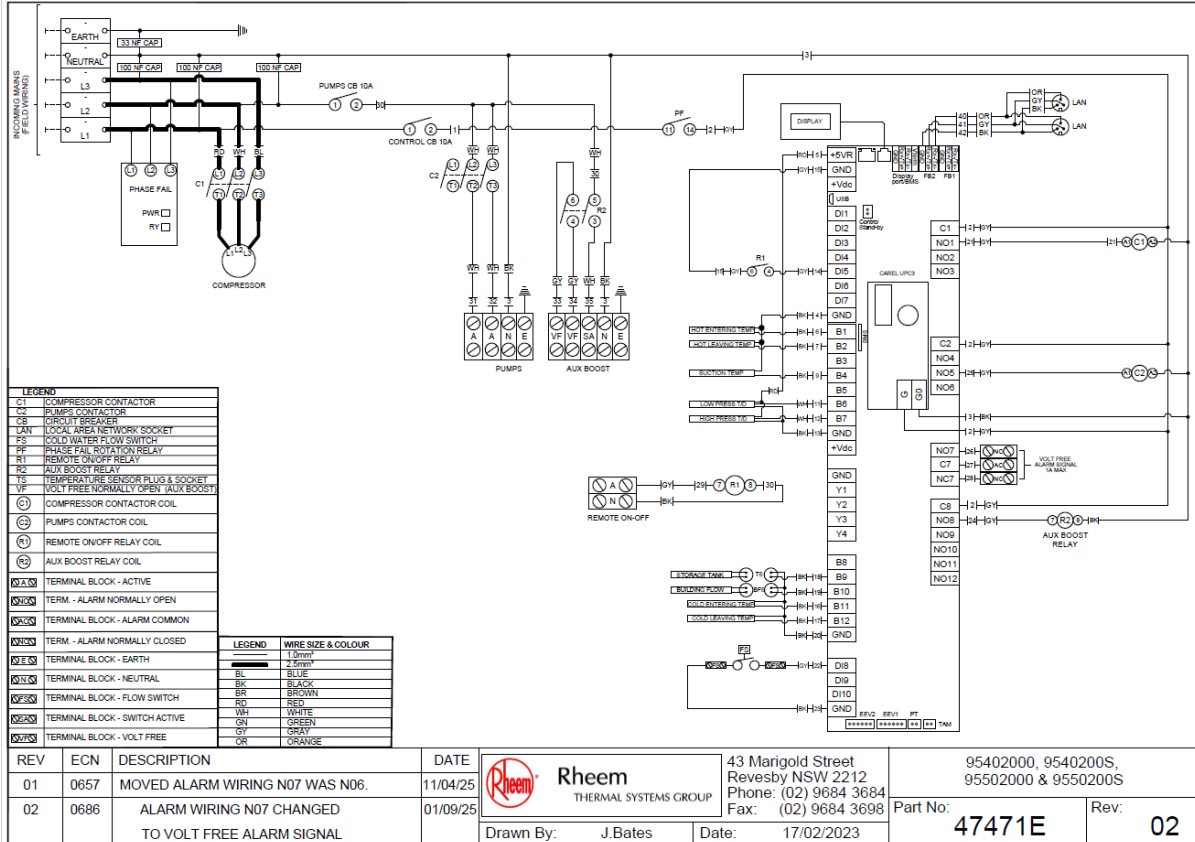

# CONNECTIONS - ELECTRICAL

## 45KW HEAT PUMP WIRING DIAGRAM

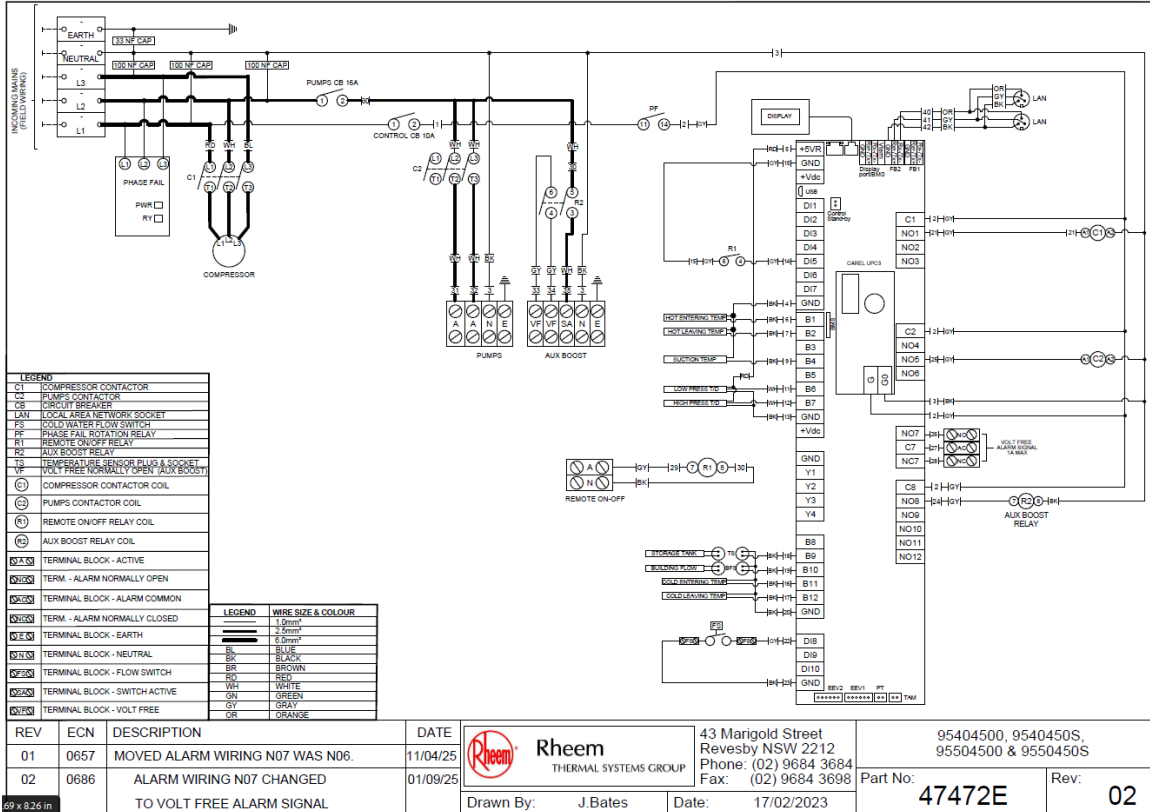

# CONNECTIONS - ELECTRICAL

## Controller and Display Information

Rheem parameter sheet 0126  
W2VWH Software V2.0.3-24

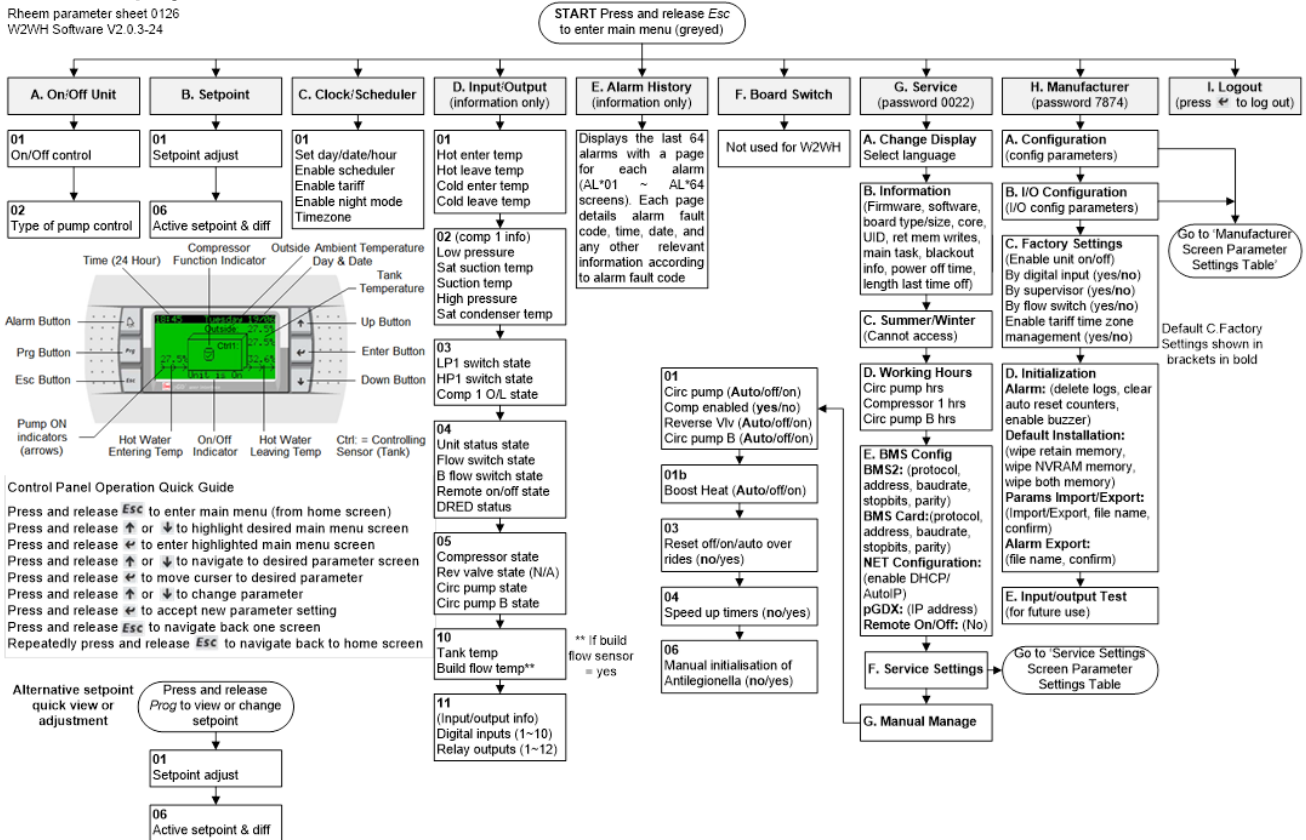

**Note:** If no keys are pressed for 60 seconds, screen reverts to main display screen and any changes made and not confirmed will be lost.

### **Set Point Quick Setting**

Press '**prg**' from the main display screen and the Set Point page will appear. Cursor will be on the set temperature. Pressing the up and down keys will adjust the setting in 0.1 increments. Hold down for rapid change. Press '**Enter**' to confirm change. Press '**esc**' to return to the main display screen. The factory setting is 61°C. The set point can be adjusted up to 65°C depending on site suitability after consulting with Rheem.

### **Menu Item**

- A. **On/Off** – Press '**enter**' to access change. Press '**up**' or '**down**' to turn unit on or off. Press '**enter**' to confirm.  
Press '**down**' key to display type of circulating pump control.  
Default: AUTOMATIC ON TEMP  
Press '**esc**' to return to Menu Master.
  
- B. **Set Point** - displays the tank maximum set point at which the compressor will be deactivated. Cursor will be on the set temperature. Pressing the '**up**' and '**down**' keys will adjust the setting in 0.1 increments. Hold down for rapid change. Press '**enter**' to confirm change. Press '**esc**' to return to the Menu Master.
  
- C. **Clock / Scheduler** – time and date are set here. Other adjustments include:
  - i. **Enable Scheduler:** No (controls heat pump operating time based on programmed time period)
  - ii. **Enable Tariff:** No (controls heat pump operating time based on tariffs)
  - iii. **Enable Night mode:** No (shifts performance to a low speed at night)
  - iv. **Time zone:** (UTC+10:00) Canberra, Melbourne, Sydney (+others equivalent) (displays the time zone of the unit)

# CONNECTIONS - ELECTRICAL

- i. **Enabling Scheduler** to 'Yes' will open a 2<sup>nd</sup> page which will allow the user to program specified operating times on a 7-day basis.  
E.g.:

**Clock Schedule**

Mon 00:00 to 00:00

Tue 00:00 to 00:00

Pressing the '**down**' key will reveal a 2<sup>nd</sup> page in the Clock Scheduler:

- Do you want to enable Special Event: No  
(programs the temperature to be maintained during a specified date range)

Enabling the Special Event to 'Yes' allows user to program in the desired date range, set point and differential to be maintained during the Special Event period.

- ii. **Enabling Tariff** to Yes will open the Tariff Time Band pages which allows the user to program which hours are off peak, shoulder and peak in 12 hour blocks as Weekday AM, Weekday PM, Weekend AM, Weekend PM.

A third page allows the user to load the default for NSW or QLD or Custom.

Press '**esc**' until page returns to the Menu Master.

# CONNECTIONS - ELECTRICAL

D. **Input/output View** – Displays the actual readings as follows:

Hot Enter Temp:	Potable water temperature entering and leaving the condenser heat exchanger (A2W and W2W heat pumps)
Hot Leave Temp:	
Cold enter Temp:	Non-potable/chilled water temperature entering and leaving the evaporator heat exchanger (W2W heat pump)
Cold Leave Temp:	
Compressor 1 –	Compressor temperature and pressure readings
Low Press:	
sat. suction:	
Suction:	
High Press:	
sat. condenser:	
LP1 switch: OK	Hi and Lo pressure switches closed or open circuit
HP1 switch: OK	
Comp O/Load: On/Off	Compressor overload activated
Unit Status:	
Flow switch:	
B Flow switch:	
Remote: On/Off	Remote control of heat pump activated
Compressor 1: On/Off	Compressor status
Rev. valve: On/Off	Reversing valve status (NA)
Fan: On/Off	Fan status (A2W heat pump)
Circ. Pump: On/Off	Primary pump/s status (NB: both non-potable/chilled and potable water pumps are activated by same relay in W2W heat pump)
Outside Temp:	Ambient air sensor temperature (A2W heat pump)
Tank Temp:	Temperature at near bottom of tank
Building Flow Temp:	Temperature being delivered to building flow
Digital Inputs:	Displays the number of inputs and outputs
Relay Outputs:	

# CONNECTIONS - ELECTRICAL

- E. **Alarm History** – will display up to 150 alarm events and then will overwrite oldest event. Alarms can be cleared by pressing the '**Alarm Bell**' key.
- F. **Board switch** – NA for W2W
- G. **Service** – password: 0022
  - a. Change display (do not use)
  - b. Information – software version information
  - c. Summer/Winter (not applicable to this product)
  - d. Working Hours:
    - i. Circ. Pump / reset counter
    - ii. Compressor 1 / reset counter
    - iii. Outdoor Fan 1 / reset counter
  - e. BMS configuration (will time out after 5 minutes if no buttons pressed)
    - Address: 1 (if BMS Interface Card Modbus on RS485 is used, change the address value based on the unique address set by the customer's network. For all other BMS interface cards, ignore this value)
  
    - Protocol: CAREL/Modbus (choose Modbus only for BMS Interface Card Modbus on RS485. For all other BMS interface cards, choose CAREL)
  
    - Speed: 19200 (if BMS Interface Card Modbus on RS485 is used, change the speed value based on the customer's network. For all other BMS interface cards, use 19200 as speed)

# CONNECTIONS - ELECTRICAL

- f. Service Settings
  - a. Working Hour Set
  - b. Prove Adjustment
  - c. Thermoregulation (for multiple heat pump installation, change the no. of compressor and other settings from here.)

f. Service Settings Screen	Parameter	Sub Parameter	Master	Slave
c. Thermoregulation	Thermoregulation 01	Setpoint	60.0°C	Screen N/A
		Differential	3.0°C	Screen N/A
		Dead band	0.5°C	Screen N/A
	Thermoregulation 04 (PumpA settings)	Flow proof delay	10s	Screen N/A
		Pump min run	5m	Screen N/A
		Pump run on time	3m	Screen N/A
		Flow recheck del	3m	Screen N/A
		Flow switch fitted	No	Screen N/A
	Thermoregulation 04a (PumpB settings)	Pump min run	5m	Screen N/A
		Pump run on time	3m	Screen N/A
		PumpB>PumpA No	10s	Screen N/A
		PumpA>Comp No	5s	Screen N/A
		Comp>PumpA Off	60s	Screen N/A
	Thermoregulation 04b (PumpB settings)	PumpA>PumpB Off	30s	Screen N/A
		Flow switch fitted	Yes	Screen N/A
	Thermoregulation 05	Blackout delay	10s	Screen N/A
		No of compressors	Set as required (default 1)	Screen N/A
		Compressor staging	Simultaneous	Screen N/A
		Controlling sensor	Tank	Screen N/A
	I/O Config 05	Out air sensor	No	No
		Sensor type	Carel NTC	Carel NTC
	Thermoregulation 06 (Enable unit On/Off)	By digital input	No	Screen N/A
		By supervisor	No	Screen N/A
		By flow switch	No	Screen N/A
		Dig input 6 is for	Comp O/Load <sup>(4)</sup>	Screen N/A
	I/O Config 06b	Storage tank temp	Yes	No
		Sensor type	Carel NTC	Carel NTC
		Building flow temp	Yes	No
	Thermoregulation 07 (HP/LP Safety)	Sensor type	Carel NTC	Carel NTC
		LP trip set	0.4 Bar	0.1 Bar
	Thermoregulation 08 (Anti-freeze safety for PHE evaporator leave)	HP trip set	27.5 Bar	27.5 Bar
		Low limit set	5.0°C	Screen N/A
	Thermoregulation 09	Aux. Boost Fitted:	Yes	Screen N/A
% compressor in alarm to activate boost		50 %	Screen N/A	
Boost. act. Delay		5m	Screen N/A	
Thermoregulation 11 (Low outside air temp) <sup>(4)</sup>	Water temp. delta too big trip point:	10.0°C	Screen N/A	
	Leaving Water Hi Temp. trip point:	71.0°C	Screen N/A	
	Leaving Water Hi Temp. reset point:	63.0°C	Screen N/A	

<sup>(1)</sup> Parameter only available where 'H. Manufacturer > Configuration 01 > No. Compressors' = 2, 3 or 4.

<sup>(2)</sup> Parameter only available where 'H. Manufacturer > Configuration 01 > No. Compressors' = 3 or 4.

<sup>(3)</sup> Parameter only available where 'H. Manufacturer > Configuration 01 > No. Compressors' = 4.

<sup>(4)</sup> Component is not present for W2WHP and should be ignored.

## d. User DEV/Change PW1

# **CONNECTIONS - ELECTRICAL**

For more information, please refer to the service manual for heat pumps.

# COMMISSIONING

## TO FILL AND TURN ON THE WATER HEATER

**The power supply to the water heater and controller must not be switched on until the water heater is filled with water and a satisfactory megger reading is obtained.**



**Warning:** This water heater contains electronic equipment and 500 V insulation tests must only be conducted between actives and earth and between neutral and earth. An active to neutral test WILL damage the electronics.

## Commissioning Procedure – Standalone Heat Pump Configuration

Perform this procedure to commission a single (standalone) heat pump. If the system is comprised of multiple standalone heat pumps, perform this procedure for each heat pump.

- Open all of the hot water tap(s) in the building (don't forget the shower(s)) and supply cock(s) and valve(s) in the system.
- Open the isolation valves fully on the cold, return and hot water branches to the storage tank(s) installed in a bank.
- Open the cold water isolation valve on the cold water line to the storage tank(s).
- Air will be forced out of the taps.
- Close each tap as water flows freely from it.
- Check the pipe work for leaks.
- Switch on the electrical supply at the isolating switch to the water heater and controller.
- Set time/tariff control if required.
- Reset alarms. Skip this step if there are no alarms.

If the water heater is full of cold water, heating will commence unless the flow rate of the cold side or the temperature of the cold side or hot side is below the set point, in which case the auxiliary boost will operate, if installed.

It is important to wait for five minutes after the heat pump has activated to ensure it continues to operate and is functioning correctly.

**Note:** The water heater may not turn on immediately when it is first switched on, if it is switched on within 20 minutes to 2 hours of it having been switched off at the isolating switch, or the heat pump has just completed a heating cycle. The water heater will wait until the conditions for start-up are favourable in order to protect the compressor from damage. This may take up to 20 minutes to 2 hours. The auxiliary booster (if installed) will operate instead of the heat pump if the temperature or the flow rate of the cold side is below the set point.

Explain to a responsible officer the functions and operation of the heat pump water heater. Upon completion of the installation and commissioning of the water heating system, leave this guide with the responsible officer.

## **Commissioning Procedure – Multiple Heat Pump (Master/Slave) Configuration**

Perform this procedure if the system is comprised of multiple heat pumps to be configured for Master/Slave operation.

- Open all of the hot water taps in the building (don't forget the showers) and supply cocks and valves in the system.
- Open the isolation valves fully on the cold, return and hot water branches to the storage tanks.
- Open the main cold water isolation valve on the cold water line to the storage tanks.
- Air will be forced out of the taps.
- Close each tap as water flows freely from it.
- Check the pipe work for leaks.





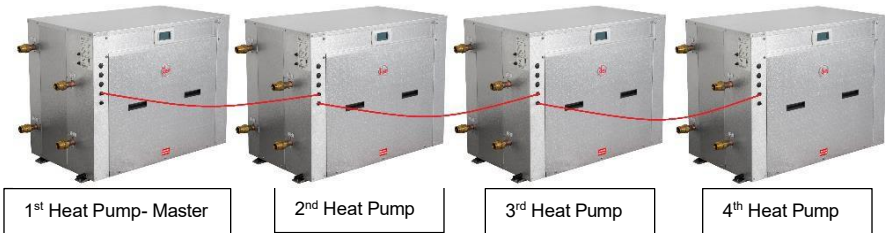

Before commencing the Master/Slave commissioning procedure, ensure the

### **'Multiple Heat Pump Installation**

- step 1 and step 2 have been completed as stated on **page 45**.

The commissioning procedure **MUST** be performed in the order shown.



1. Ensure all heat pumps are turned OFF at the isolating switch.
2. Turn ON slave 1 heat pump (2<sup>nd</sup> heat pump).
3. Configure heat pump address.
  - Whilst in the home screen on control panel, simultaneously press and hold Up , Down  and Enter  for 5 seconds to enter the setup menu.
  - Use Up  or Down  buttons to set values.
  - Press and release Enter  to move cursor to next line.
  - Change the following values as shown below.

Menu	Slave 1	Slave 2	Slave 3	Master	Example Screen Image of Slave 1
Display address setting	17	18	19	16	
I/O board address	02	03	04	01	
trm1	32	32	32	32	
trm2	17	18	19	16	
trm3 None -Ok?	Yes	Yes	Yes	Yes	

- Press “Enter”  to confirm settings. The screen will change to the home screen and settings will be saved.

Note that the slave's pump will start and an alarm may occur – ignore at this stage.

4. Change slave heat pump 'Storage tank temp' sensor and 'Building flow temp' sensor parameters to 'No'.
  - Go to the Service menu (Service>Service Settings- password 0022>Thermoregulation). Refer to [page 50](#) to see the chart for navigating Service menu and [page 55](#) for Thermoregulation section or see the table below.

Parameter	Sub Parameter	Master	Slave
Thermoregulation 05	Blackout delay	15s	Screen N/A
	No of compressors	Set as required (default 1)	Screen N/A
	Compressor staging	Simultaneous	Screen N/A
	Controlling sensor	Tank	Screen N/A
I/O Config 05	Out air sensor	No	No
	Sensor type	Carel NTC	Carel NTC
Thermoregulation 06 (Enable unit On/Off)	By digital input	No	Screen N/A
	By supervisor	No	Screen N/A
	By flow switch	Not avail	Screen N/A
	Dig input 6 is for:	Comp O/Load	Screen N/A
	<b>Storage tank temp</b>	Yes	<b>No</b>
I/O Config 06b	Sensor type	Carel NTC	Carel NTC
	<b>Building flow temp</b>	No	<b>No</b>

5. Turn OFF the Slave heat pump.
  - If there is only 1 slave proceed directly to step 6.
  - If there are 2 or 3 Slave heat pumps repeat step 3 to step 5 for Slave 2 and Slave 3 respectively using the values for respective Slave heat pumps.
6. Turn ON Master heat pump and set the master address as stated in step 3.
7. After commissioning the Master heat pump, go to the Service menu (Service>Service Settings- password 0022>Thermoregulation>no. of compressor) on the Master heat pump and change the number of compressors according to the number of heat pumps interconnected together.



Refer to [page 50](#) to see the chart for navigating Service menu and [page 55](#) for Thermoregulation section or see the table below.

Parameter	Sub Parameter	Master
Thermoregulation 05	Blackout delay	10s
	<b>No of compressors</b> (Number of heat pumps)	<b>Set as required</b> <b>(default 1)</b>
	Compressor staging	Simultaneous
	Controlling sensor	Tank

8. Turn on all the heat pumps.
9. Reset alarms on each heat pump. Skip this step if there are no alarms.

**10.** Set time/tariff control on Master heat pump if required. Refer to **page 50** to see the chart for navigating the control panel display.

If the water heater is full of cold water, heating will commence unless the flow rate of the cold side or the temperature of the cold side and hot side is below the set point, in which case the auxiliary boost will operate, if installed.

It is important to wait for five minutes after the heat pump has activated to ensure it continues to operate and is functioning correctly.

**Note:** The water heater may not turn on immediately when it is first switched on, if it is switched on within 20 minutes to 2 hours of it having been switched off at the isolating switch, or the heat pump has just completed a heating cycle. The water heater will wait until the conditions for start-up are favorable in order to protect the compressor from damage. This may take up to 20 minutes to 2 hours. The auxiliary booster (if installed) will operate instead of the heat pump if the temperature or the flow rate of the cold side is below the set point.

Explain to a responsible officer the functions and operation of the heat pump water heater. Upon completion of the installation and commissioning of the water heating system, leave this guide with the responsible officer.

## Commissioning Procedure- BMS Configuration

Before commencing the commissioning procedure, ensure the '**Building Management Systems (BMS/BAS)**' installation procedure has been completed as stated on page 47.

- If the system is comprised of single or multiple standalone heat pumps, perform this procedure for each heat pump. Each heat pump will have its own BMS card.
- If the system is comprised of multiple heat pumps for Master/Slave operation, perform this procedure for only master heat pump. Only master heat pump will have a BMS card and the slave heat pumps will be connected via LAN cable.

Configure BMS settings from the display of the heat pump.

After commissioning the Master heat pump, go to the Service menu (Service- password 0022>BMS config). Refer to page 50 to see the chart for navigating Service menu.

### Configuration: BMS Interface Card Modbus on RS485

1. Go to BMS configuration (will time out after 5 minutes if no buttons pressed)

Change the settings for BMS configuration from the display menu as mentioned below.

**Address:** Change the address value based on the unique address set by the customer's network.

**Protocol:** Choose option 'Modbus'

**Speed:** Change the speed value based on the customer's network.

2. Parameter table is provide for customers to follow for further configuration to customer's network on page 64.

### Configuration: BMS Interface card BACnet MS-TP

1. Go to BMS configuration (will time out after 5 minutes if no buttons pressed)

Change the settings for BMS configuration from the display menu as mentioned below.

**Address:** No change required (address is irrelevant for this card).

**Protocol:** CAREL

**Speed:** 19200 (this value is set from factory to communicate between heat pump and BMS card)

2. Open the heat pump enclosure and check the BMS card.

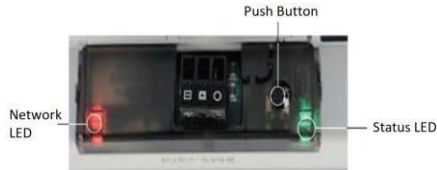

The BACnet MS-TP card features a button (PUSHBUTTON) and two indicator lights (STATUS LED and NETWORK LED).

Functions of the button: When starting up the BACnet MS-TP, this is used to select, for network communication, whether to use the factory parameters or the user parameters

In normal operation, reboots BACnet MS-TP without needing to disconnect the power supply

Status LED: indicates the status of communication with the heat pump and the card. Once the starting sequence has been completed, the Status LED flashes to indicate the quality of communication.

- a. If Status LED flashes green, then communication with the BACnet MS-TP is OK.
- b. If LED is red or green-red-green, then the communication is not established. In that case, check the BMS configuration.

Network LED: The Network LED (right) indicates the status of communication with customer's network. Once the starting sequence has been completed, the Network LED flashes to indicate the quality of communication with customer's network.

- a. If Network LED flashes green with occasional red flashes then communication is OK.
  - b. If Network LED flashes green and red ON together (BACnet MS/TP meaning: continuous Poll-For-Master): communication not established (connection problems, or no network device found); this may depend on electrical connection difficulties or communication settings that are not compatible with the other network devices connected.
3. For further configuration of BACnet MS-TP card, please follow the "BACnet MS-TP Configuration Guide".
  4. Parameter table is provided for customers to follow for further configuration to customer's network on **page 64**.

## Configuration: BMS Interface card BACnet TCP/IP Ethernet

1. Go to BMS configuration (will time out after 5 minutes if no buttons pressed)

Change the settings for BMS configuration from the display menu as mentioned below.

**Address:** No change required (address is irrelevant for this card).

**Protocol:** CAREL

**Speed:** 19200 (this value is set from factory to communicate between heat pump and BMS card)

2. Open the heat pump enclosure and check the BMS card.

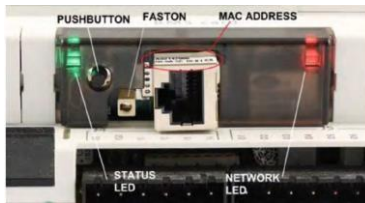

The BACnet TCP/IP Ethernet card features a button (PUSHBUTTON) and two indicator lights (STATUS LED and NETWORK LED).

Functions of the button: When starting up the TCP/IP Ethernet card, this is used to select, for network communication, whether to use the factory parameters or the user parameters. In normal operation, reboots TCP/IP Ethernet card without needing to disconnect the power supply.

Status LED: indicates the status of communication with the heat pump and the card. Once the starting sequence has been completed, the Status LED flashes to indicate the quality of communication.

- a. If Status LED flashes green or green steady, then communication with the BACnet TCP/IP Ethernet card is OK.
- b. If LED is red or green-red-green, then the communication is not established. In that case, check the BMS configuration.

Network LED: Displays the status of the physical network connection (Ethernet connection signals), regardless of whether the network parameters are correct; usually this must be green and flash when data is transmitted/received.

3. For further configuration of BACnet TCP/IP Ethernet card, please follow the "BACnet TCP/IP Ethernet Configuration Guide".
4. Parameter table is provided for customers to follow for further configuration to customer's network on **page 64**.

Refer to the parameter tables below for BMS:

Types	Index	Size	Variable Name	Variable Description	DataType	Default Value	Min	Max	UoM	Direction
Coil	1	1	DummyBol_01		Bool				NoUnits	ReadWrite
Coil	2	1	DummyBol_02		Bool				NoUnits	ReadWrite
Coil	3	1	DummyBol_03		Bool				NoUnits	ReadWrite
Coil	4	1	DummyBol_04		Bool				NoUnits	ReadWrite
Coil	5	1	DummyBol_05		Bool				NoUnits	ReadWrite
Coil	6	1	DummyBol_06		Bool				NoUnits	ReadWrite
Coil	7	1	DummyBol_07		Bool				NoUnits	ReadWrite
Coil	8	1	DummyBol_08		Bool				NoUnits	ReadWrite
Coil	9	1	DummyBol_09		Bool				NoUnits	ReadWrite
Coil	10	1	DummyBol_10		Bool				NoUnits	ReadWrite
Coil	19	1	Dout_01	Relay Output 01	Bool				NoUnits	ReadWrite
Coil	20	1	Dout_02	Relay Output 02	Bool				NoUnits	ReadWrite
Coil	21	1	Dout_03	Relay Output 03	Bool				NoUnits	ReadWrite
Coil	22	1	Dout_04	Relay Output 04	Bool				NoUnits	ReadWrite
Coil	23	1	Dout_05	Relay Output 05	Bool				NoUnits	ReadWrite
Coil	24	1	Dout_06	Relay Output 06	Bool				NoUnits	ReadWrite
Coil	25	1	Dout_07	Relay Output 07	Bool				NoUnits	ReadWrite
Coil	26	1	Dout_08	Relay Output 08	Bool				NoUnits	ReadWrite
Coil	27	1	Dout_09	Relay Output 09	Bool				NoUnits	ReadWrite
Coil	28	1	Dout_10	Relay Output 10	Bool				NoUnits	ReadWrite
Coil	29	1	Dout_11	Relay Output 11	Bool				NoUnits	ReadWrite
Coil	30	1	Dout_12	Relay Output 12	Bool				NoUnits	ReadWrite
Coil	31	1	Dout_13	Relay Output 13	Bool				NoUnits	ReadWrite

Coil	32	1	Pmp	Circulating Pump	Bool				NoUnits	ReadWrite
Coil	33	1	PmpB	Circulating Pump for Source water	Bool				NoUnits	ReadWrite
Coil	35	1	Comp1_En	remote / maintenance enable of compressor 1	Bool	TRUE			NoUnits	ReadWrite
Coil	36	1	Comp2_En	remote / maintenance enable of compressor 2	Bool	TRUE			NoUnits	ReadWrite
Coil	37	1	Comp3_En	remote / maintenance enable of compressor 3	Bool	TRUE			NoUnits	ReadWrite
Coil	38	1	Comp4_En	remote / maintenance enable of compressor 4	Bool	TRUE			NoUnits	ReadWrite
Coil	39	1	Comp5_En	remote / maintenance enable of compressor 5	Bool	TRUE			NoUnits	ReadWrite
Coil	40	1	Comp6_En	remote / maintenance enable of compressor 6	Bool	TRUE			NoUnits	ReadWrite
Coil	41	1	DeviceStatusComp1	Actual status of compressor 1	Bool				NoUnits	ReadWrite
Coil	42	1	DeviceStatusComp2	Actual status of compressor 2	Bool				NoUnits	ReadWrite
Coil	43	1	DeviceStatusComp3	Actual status of compressor 3	Bool				NoUnits	ReadWrite
Coil	44	1	DeviceStatusComp4	Actual status of compressor 4	Bool				NoUnits	ReadWrite
Coil	45	1	DeviceStatusComp5	Actual status of compressor 5	Bool				NoUnits	ReadWrite
Coil	46	1	DeviceStatusComp6	Actual status of compressor 6	Bool				NoUnits	ReadWrite
Coil	49	1	UnitOn	Unit On status: TRUE = Unit ON	Bool				NoUnits	ReadWrite
Coil	50	1	OnOffUnitMng.BmsOnOff	Unit On/Off by BMS	Bool				NoUnits	ReadWrite
Coil	51	1	AlarmMng.AlrmResByBms	Alarm reset by BMS	Bool				NoUnits	ReadWrite
Coil	52	1	En_tfr	Enable Tariff	Bool	TRUE			NoUnits	ReadWrite
Coil	53	1	DeviceStatusRevVlv1	Actual status of Reverse Valve 1	Bool				NoUnits	ReadWrite
Coil	54	1	DeviceStatusRevVlv2	Actual status of Reverse Valve 2	Bool				NoUnits	ReadWrite
Coil	55	1	DeviceStatusRevVlv3	Actual status of Reverse Valve 3	Bool				NoUnits	ReadWrite
Coil	56	1	DeviceStatusRevVlv4	Actual status of Reverse Valve 4	Bool				NoUnits	ReadWrite
Coil	57	1	DeviceStatusRevVlv5	Actual status of Reverse Valve 5	Bool				NoUnits	ReadWrite
Coil	58	1	DeviceStatusRevVlv6	Actual status of Reverse Valve 6	Bool				NoUnits	ReadWrite
Coil	60	1	En_Elect_Heat	Electric boost element is installed	Bool	TRUE			NoUnits	ReadWrite

Coil	61	1	BMS_Boost	Boost heat activated by BMS	Bool			NoUnits	ReadWrite
Coil	62	1	En_BMS_demand	Enable BMS demand capacity	Bool			NoUnits	ReadWrite
Coil	63	1	En_PwrLim	Enable power limiting	Bool			NoUnits	ReadWrite
Coil	64	1	EnSchedOnOff	Enable Scheduler	Bool			NoUnits	ReadWrite
Coil	65	1	Special_act	Special timezone active	Bool			NoUnits	ReadWrite
Coil	66	1	LowAmbMode	Enable Setback offset	Bool			NoUnits	ReadWrite
Coil	67	1	En_NightMode	Enable Night Mode	Bool			NoUnits	ReadWrite
Coil	68	1	Night_act	Night Mode active	Bool			NoUnits	ReadWrite
Coil	69	1	En_FrostSaf	Enable frost protection safety	Bool	TRUE		NoUnits	ReadWrite
Coil	70	1	Pmp_HR_Res	Pump hour run reset	Bool			NoUnits	ReadWrite
Coil	71	1	PmpB_HR_Res	Pump B hour run reset	Bool			NoUnits	ReadWrite
Coil	72	1	Comp_HR_Res1	Compressor 1 Hour run reset	Bool			NoUnits	ReadWrite
Coil	73	1	Comp_HR_Res2	Compressor 2 Hour run reset	Bool			NoUnits	ReadWrite
Coil	74	1	Comp_HR_Res3	Compressor 3 Hour run reset	Bool			NoUnits	ReadWrite
Coil	75	1	Comp_HR_Res4	Compressor 4 Hour run reset	Bool			NoUnits	ReadWrite
Coil	76	1	Comp_HR_Res5	Compressor 5 Hour run reset	Bool			NoUnits	ReadWrite
Coil	77	1	Comp_HR_Res6	Compressor 6 Hour run reset	Bool			NoUnits	ReadWrite
Coil	78	1	OdoorFanHR_Res1	Outdoor fan 1 hour run reset	Bool			NoUnits	ReadWrite
Coil	79	1	OdoorFanHR_Res2	Outdoor fan 2 hour run reset	Bool			NoUnits	ReadWrite
Coil	80	1	OdoorFanHR_Res3	Outdoor fan 3 hour run reset	Bool			NoUnits	ReadWrite
Coil	81	1	OdoorFanHR_Res4	Outdoor fan 4 hour run reset	Bool			NoUnits	ReadWrite
Coil	82	1	OdoorFanHR_Res5	Outdoor fan 5 hour run reset	Bool			NoUnits	ReadWrite
Coil	83	1	OdoorFanHR_Res6	Outdoor fan 6 hour run reset	Bool			NoUnits	ReadWrite
Coil	84	1	Flw_SW_Present	Flow switch present	Bool	TRUE		NoUnits	ReadWrite
Coil	85	1	EnLWTCtrl	Enable Leaving water temp control	Bool			NoUnits	ReadWrite

Coil	86	1	En_CompLowAmb	Keep compressor enabled in low ambient condition	Bool	TRUE		NoUnits	ReadWrite
Coil	87	1	En_PoolSpa	Pool/Spa Installed	Bool			NoUnits	ReadWrite
Coil	119	1	GlbAlrm	Global alarms (at least one active alarm)	Bool			NoUnits	Read
Coil	120	1	Al_Prb_01.Trigger	Probe 01 Alarm - Alarm status Trigger	Bool			NoUnits	ReadWrite
Coil	121	1	Al_Prb_02.Trigger	Probe 02 Alarm - Alarm status Trigger	Bool			NoUnits	ReadWrite
Coil	122	1	Al_Prb_03.Trigger	Probe 03 Alarm - Alarm status Trigger	Bool			NoUnits	ReadWrite
Coil	123	1	Al_Prb_04.Trigger	Probe 04 Alarm - Alarm status Trigger	Bool			NoUnits	ReadWrite
Coil	124	1	Al_Prb_05.Trigger	Probe 05 Alarm - Alarm status Trigger	Bool			NoUnits	ReadWrite
Coil	125	1	Al_Prb_06.Trigger	Probe 06 Alarm - Alarm status Trigger	Bool			NoUnits	ReadWrite
Coil	126	1	Al_Prb_07.Trigger	Probe 07 Alarm - Alarm status Trigger	Bool			NoUnits	ReadWrite
Coil	127	1	Al_Prb_08.Trigger	Probe 08 Alarm - Alarm status Trigger	Bool			NoUnits	ReadWrite
Coil	128	1	Al_Prb_09.Trigger	Probe 09 Alarm - Alarm status Trigger	Bool			NoUnits	ReadWrite
Coil	129	1	Al_Prb_10.Trigger	Probe 10 Alarm - Alarm status Trigger	Bool			NoUnits	ReadWrite
Coil	130	1	Al_Prb_11.Trigger	Probe 11 Alarm - Alarm status Trigger	Bool			NoUnits	ReadWrite
Coil	131	1	Al_Prb_12.Trigger	Probe 12 Alarm - Alarm status Trigger	Bool			NoUnits	ReadWrite
Coil	132	1	DeviceAlarmComp1	Alarm Comp 1	Bool			NoUnits	ReadWrite
Coil	133	1	DeviceAlarmComp2	Alarm Comp 2	Bool			NoUnits	ReadWrite
Coil	134	1	DeviceAlarmComp3	Alarm Comp 3	Bool			NoUnits	ReadWrite
Coil	135	1	DeviceAlarmComp4	Alarm Comp 4	Bool			NoUnits	ReadWrite
Coil	136	1	DeviceAlarmComp5	Alarm Comp 5	Bool			NoUnits	ReadWrite
Coil	137	1	DeviceAlarmComp6	Alarm Comp 6	Bool			NoUnits	ReadWrite
Coil	138	1	Comp1OL	Compressor 1 O/L	Bool			NoUnits	ReadWrite
Coil	139	1	Comp2OL	Compressor 2 O/L	Bool			NoUnits	ReadWrite
Coil	140	1	Comp3OL	Compressor 3 O/L	Bool			NoUnits	ReadWrite
Coil	141	1	Comp4OL	Compressor 4 O/L	Bool			NoUnits	ReadWrite

Coil	142	1	Comp5OL	Compressor 5 O/L	Bool			NoUnits	ReadWrite
Coil	143	1	Comp6OL	Compressor 6 O/L	Bool			NoUnits	ReadWrite
Coil	144	1	TDelta_AL1	Temperature Delta Alarm 1 (Hot side)	Bool			NoUnits	ReadWrite
Coil	145	1	TDelta_AL2	Temperature Delta Alarm 2 (Hot side)	Bool			NoUnits	ReadWrite
Coil	146	1	TDelta_AL3	Temperature Delta Alarm 3 (Hot side)	Bool			NoUnits	ReadWrite
Coil	147	1	TDelta_AL4	Temperature Delta Alarm 4 (Hot side)	Bool			NoUnits	ReadWrite
Coil	148	1	TDelta_AL5	Temperature Delta Alarm 5 (Hot side)	Bool			NoUnits	ReadWrite
Coil	149	1	TDelta_AL6	Temperature Delta Alarm 6 (Hot side)	Bool			NoUnits	ReadWrite
Coil	150	1	TDeltaB_AL1	Temperature Delta Alarm 1 (Cool side)	Bool			NoUnits	ReadWrite
Coil	151	1	TDeltaB_AL2	Temperature Delta Alarm 2 (Cool side)	Bool			NoUnits	ReadWrite
Coil	152	1	TDeltaB_AL3	Temperature Delta Alarm 3 (Cool side)	Bool			NoUnits	ReadWrite
Coil	153	1	TDeltaB_AL4	Temperature Delta Alarm 4 (Cool side)	Bool			NoUnits	ReadWrite
Coil	154	1	TDeltaB_AL5	Temperature Delta Alarm 5 (Cool side)	Bool			NoUnits	ReadWrite
Coil	155	1	TDeltaB_AL6	Temperature Delta Alarm 6 (Cool side)	Bool			NoUnits	ReadWrite
Coil	156	1	AI_LWT_Hi.Trigger	High Leaving Water Temperature Alarm - Alarm status Trigger	Bool			NoUnits	ReadWrite
HoldingRegister	1	1	BMS_DummyReal_01		Int			NoUnits	ReadWrite
HoldingRegister	2	1	BMS_DummyReal_02		Int			NoUnits	ReadWrite
HoldingRegister	3	1	BMS_DummyReal_03		Int			NoUnits	ReadWrite
HoldingRegister	4	1	BMS_DummyReal_04		Int			NoUnits	ReadWrite
HoldingRegister	5	1	BMS_DummyReal_05		Int			NoUnits	ReadWrite
HoldingRegister	6	1	BMS_DummyReal_06		Int			NoUnits	ReadWrite
HoldingRegister	7	1	BMS_DummyReal_07		Int			NoUnits	ReadWrite
HoldingRegister	8	1	BMS_DummyReal_08		Int			NoUnits	ReadWrite
HoldingRegister	9	1	BMS_DummyReal_09		Int			NoUnits	ReadWrite
HoldingRegister	10	1	BMS_DummyReal_10		Int			NoUnits	ReadWrite

HoldingRegister	11	1	BMS_DummyReal_11		Int			NoUnits	ReadWrite
HoldingRegister	12	1	BMS_DummyReal_12		Int			NoUnits	ReadWrite
HoldingRegister	13	1	BMS_Aout_01	Modulating Output 01	Int			NoUnits	ReadWrite
HoldingRegister	14	1	BMS_Aout_02	Modulating Output 02	Int			NoUnits	ReadWrite
HoldingRegister	15	1	BMS_Aout_03	Modulating Output 03	Int			NoUnits	ReadWrite
HoldingRegister	16	1	BMS_Aout_04	Modulating Output 04	Int			NoUnits	ReadWrite
HoldingRegister	17	1	BMS_Aout_05	Modulating Output 05	Int			NoUnits	ReadWrite
HoldingRegister	18	1	BMS_Aout_06	Modulating Output 06	Int			NoUnits	ReadWrite
HoldingRegister	23	1	BMS_CtrlT	Current Controlling Temperature	Int			NoUnits	ReadWrite
HoldingRegister	24	1	BMS_OAT	Outside Air Temperature	Int			NoUnits	ReadWrite
HoldingRegister	25	1	BMS_EW_T	Entering Water Temperature (Hot side)	Int			NoUnits	ReadWrite
HoldingRegister	26	1	BMS_LW_T	Leaving Water Temperature (Hot side)	Int			NoUnits	ReadWrite
HoldingRegister	27	1	BMS_CondT	Condenser Temperature	Int			NoUnits	ReadWrite
HoldingRegister	28	1	BMS_setP_active	Current Active Setpoint	Int			NoUnits	ReadWrite
HoldingRegister	29	1	BMS_diff_active	Current Active Differential	Int			NoUnits	ReadWrite
HoldingRegister	30	1	BMS_SetP	Setpoint (non Pool / Spa)	Int			NoUnits	ReadWrite
HoldingRegister	31	1	BMS_Ctrl_DB	Control Dead Band	Int			NoUnits	ReadWrite
HoldingRegister	32	1	BMS_PB	Proportional Band / Differential	Int			NoUnits	ReadWrite
HoldingRegister	33	1	BMS_EW_TB	Entering Water Temperature (Cold side)	Int			NoUnits	ReadWrite
HoldingRegister	34	1	BMS_LW_TB	Leaving Water Temperature (Cold side)	Int			NoUnits	ReadWrite
HoldingRegister	35	1	BMS_TankT	Tank Temperature	Int			NoUnits	ReadWrite
HoldingRegister	36	1	BMS_Bld_SupplyT	Building Supply Temperature	Int			NoUnits	ReadWrite
HoldingRegister	39	1	BMS_WaterDelta	Entering Vs Leaving water temperature delta	Int			NoUnits	ReadWrite
HoldingRegister	50	1	BMS_LW_HiTrip	Leave Water Hi Trip Temperature	Int			NoUnits	ReadWrite
HoldingRegister	51	1	BMS_LW_HiRes	Leave Water Hi Reset Temperature	Int			NoUnits	ReadWrite
HoldingRegister	52	1	BMS_LW_LoTrip	Leave Water Lo Trip Temperature	Int			NoUnits	ReadWrite

HoldingRegister	53	1	BMS_LW_LoRes	Leave Water Lo Reset Temperature	Int				NoUnits	ReadWrite
HoldingRegister	54	1	BMS_EW_LoTrip	Entering Water Lo Trip Temperature	Int				NoUnits	ReadWrite
HoldingRegister	55	1	BMS_EW_LoReset	Entering Water Lo Reset Temperature	Int				NoUnits	ReadWrite
HoldingRegister	56	1	BMS_Comp_HiTrip	Compressor Discharge Temperature Trip	Int				NoUnits	ReadWrite
HoldingRegister	60	1	BMS_BLDC_spd		Int				NoUnits	ReadWrite
HoldingRegister	65	1	BMS_EEV_pos		Int				NoUnits	ReadWrite
HoldingRegister	100	1	BMS_tfr_0_set		Int				NoUnits	ReadWrite
HoldingRegister	101	1	BMS_tfr_1_set		Int				NoUnits	ReadWrite
HoldingRegister	102	1	BMS_tfr_2_set		Int				NoUnits	ReadWrite
HoldingRegister	103	1	BMS_tfr_3_set		Int				NoUnits	ReadWrite
HoldingRegister	104	1	BMS_tfr_0_diff		Int				NoUnits	ReadWrite
HoldingRegister	105	1	BMS_tfr_1_diff		Int				NoUnits	ReadWrite
HoldingRegister	106	1	BMS_tfr_2_diff		Int				NoUnits	ReadWrite
HoldingRegister	107	1	BMS_tfr_3_diff		Int				NoUnits	ReadWrite
HoldingRegister	108	1	BMS_DRED_SetP_Offset		Int				NoUnits	ReadWrite
HoldingRegister	109	1	BMS_DRED_SetP_Abs		Int				NoUnits	ReadWrite
HoldingRegister	110	1	BMS_DRED_diff_Offset		Int				NoUnits	ReadWrite
HoldingRegister	111	1	BMS_DRED_diff_Abs		Int				NoUnits	ReadWrite
HoldingRegister	112	1	BMS_SetbackLoLim		Int				NoUnits	ReadWrite
HoldingRegister	113	1	BMS_SetbackUpLim		Int				NoUnits	ReadWrite
HoldingRegister	114	1	BMS_SetbackDelta		Int				NoUnits	ReadWrite
HoldingRegister	115	1	BMS_OAT_Lo		Int				NoUnits	ReadWrite
HoldingRegister	116	1	BMS_OAT_LoDiff		Int				NoUnits	ReadWrite
HoldingRegister	117	1	BMS_PoolSetP		Int				NoUnits	ReadWrite
HoldingRegister	118	1	BMS_PoolDiff		Int				NoUnits	ReadWrite
HoldingRegister	119	1	BMS_SpaSetP		Int				NoUnits	ReadWrite

HoldingRegister	120	1	BMS_SpaDiff		Int				NoUnits	ReadWrite
HoldingRegister	121	1	BMS_FrostSetp		Int				NoUnits	ReadWrite
HoldingRegister	122	1	BMS_FrostDiff		Int				NoUnits	ReadWrite
HoldingRegister	167	1	BMS_PumpSpeedMax		Int				NoUnits	ReadWrite
HoldingRegister	168	1	BMS_PumpSpeedMin		Int				NoUnits	ReadWrite
HoldingRegister	169	1	BMS_LWT_PB		Int				NoUnits	ReadWrite
HoldingRegister	170	1	BMS_LWT_Ti		Int				NoUnits	ReadWrite
HoldingRegister	171	1	BMS_LWT_Td		Int				NoUnits	ReadWrite
HoldingRegister	173	1	BMS_PoolPrb		Int				NoUnits	ReadWrite
HoldingRegister	174	1	BMS_SpaPrb		Int				NoUnits	ReadWrite
HoldingRegister	175	1	BMS_LP_P_set		Int				NoUnits	ReadWrite
HoldingRegister	176	1	BMS_HP_P_set		Int				NoUnits	ReadWrite
HoldingRegister	177	1	BMS_De_Ice_init		Int				NoUnits	ReadWrite
HoldingRegister	178	1	BMS_De_Ice_Thrsh		Int				NoUnits	ReadWrite
HoldingRegister	179	1	BMS_MaxDemandLim		Int				NoUnits	ReadWrite
HoldingRegister	5002	1	tfr_00	type of tariff - timeband 0 weekday	Int	0	2		NoUnits	ReadWrite
HoldingRegister	5003	1	tfr_01	type of tariff - timeband 1 weekday	Int	0	2		NoUnits	ReadWrite
HoldingRegister	5004	1	tfr_02	type of tariff - timeband 2 weekday	Int	0	2		NoUnits	ReadWrite
HoldingRegister	5005	1	tfr_03	type of tariff - timeband 3 weekday	Int	0	2		NoUnits	ReadWrite
HoldingRegister	5006	1	tfr_04	type of tariff - timeband 4 weekday	Int	0	2		NoUnits	ReadWrite
HoldingRegister	5007	1	tfr_05	type of tariff - timeband 5 weekday	Int	0	2		NoUnits	ReadWrite
HoldingRegister	5008	1	tfr_06	type of tariff - timeband 6 weekday	Int	0	2		NoUnits	ReadWrite
HoldingRegister	5009	1	tfr_07	type of tariff - timeband 7 weekday	Int	0	2		NoUnits	ReadWrite
HoldingRegister	5010	1	tfr_08	type of tariff - timeband 8 weekday	Int	0	2		NoUnits	ReadWrite
HoldingRegister	5011	1	tfr_09	type of tariff - timeband 9 weekday	Int	0	2		NoUnits	ReadWrite
HoldingRegister	5012	1	tfr_10	type of tariff - timeband 10 weekday	Int	0	2		NoUnits	ReadWrite

HoldingRegister	5013	1	tfr_11	type of tariff - timeband 11 weekday	Int		0	2	NoUnits	ReadWrite
HoldingRegister	5014	1	tfr_12	type of tariff - timeband 12 weekday	Int		0	2	NoUnits	ReadWrite
HoldingRegister	5015	1	tfr_13	type of tariff - timeband 13 weekday	Int		0	2	NoUnits	ReadWrite
HoldingRegister	5016	1	tfr_14	type of tariff - timeband 14 weekday	Int		0	2	NoUnits	ReadWrite
HoldingRegister	5017	1	tfr_15	type of tariff - timeband 15 weekday	Int		0	2	NoUnits	ReadWrite
HoldingRegister	5018	1	tfr_16	type of tariff - timeband 16 weekday	Int		0	2	NoUnits	ReadWrite
HoldingRegister	5019	1	tfr_17	type of tariff - timeband 17 weekday	Int		0	2	NoUnits	ReadWrite
HoldingRegister	5020	1	tfr_18	type of tariff - timeband 18 weekday	Int		0	2	NoUnits	ReadWrite
HoldingRegister	5021	1	tfr_19	type of tariff - timeband 19 weekday	Int		0	2	NoUnits	ReadWrite
HoldingRegister	5022	1	tfr_20	type of tariff - timeband 20 weekday	Int		0	2	NoUnits	ReadWrite
HoldingRegister	5023	1	tfr_21	type of tariff - timeband 21 weekday	Int		0	2	NoUnits	ReadWrite
HoldingRegister	5024	1	tfr_22	type of tariff - timeband 22 weekday	Int		0	2	NoUnits	ReadWrite
HoldingRegister	5025	1	tfr_23	type of tariff - timeband 23 weekday	Int		0	2	NoUnits	ReadWrite
HoldingRegister	5026	1	trfw_00	type of tariff - timeband 0 week end	Int	0	0	2	NoUnits	ReadWrite
HoldingRegister	5027	1	trfw_01	type of tariff - timeband 1 week end	Int		0	2	NoUnits	ReadWrite
HoldingRegister	5028	1	trfw_02	type of tariff - timeband 2 week end	Int		0	2	NoUnits	ReadWrite
HoldingRegister	5029	1	trfw_03	type of tariff - timeband 3 week end	Int		0	2	NoUnits	ReadWrite
HoldingRegister	5030	1	trfw_04	type of tariff - timeband 4 week end	Int		0	2	NoUnits	ReadWrite
HoldingRegister	5031	1	trfw_05	type of tariff - timeband 5 week end	Int		0	2	NoUnits	ReadWrite
HoldingRegister	5032	1	trfw_06	type of tariff - timeband 6 week end	Int		0	2	NoUnits	ReadWrite
HoldingRegister	5033	1	trfw_07	type of tariff - timeband 7 week end	Int		0	2	NoUnits	ReadWrite
HoldingRegister	5034	1	trfw_08	type of tariff - timeband 8 week end	Int		0	2	NoUnits	ReadWrite
HoldingRegister	5035	1	trfw_09	type of tariff - timeband 9 week end	Int		0	2	NoUnits	ReadWrite
HoldingRegister	5036	1	trfw_10	type of tariff - timeband 10 week end	Int	0	0	2	NoUnits	ReadWrite
HoldingRegister	5037	1	trfw_11	type of tariff - timeband 11 week end	Int	0	0	2	NoUnits	ReadWrite

HoldingRegister	5038	1	trfw_12	type of tariff - timeband 12 week end	Int	0	0	2	NoUnits	ReadWrite
HoldingRegister	5039	1	trfw_13	type of tariff - timeband 13 week end	Int	0	0	2	NoUnits	ReadWrite
HoldingRegister	5040	1	trfw_14	type of tariff - timeband 14 week end	Int	0	0	2	NoUnits	ReadWrite
HoldingRegister	5041	1	trfw_15	type of tariff - timeband 15 week end	Int	0	0	2	NoUnits	ReadWrite
HoldingRegister	5042	1	trfw_16	type of tariff - timeband 16 week end	Int	0	0	2	NoUnits	ReadWrite
HoldingRegister	5043	1	trfw_17	type of tariff - timeband 17 week end	Int	0	0	2	NoUnits	ReadWrite
HoldingRegister	5044	1	trfw_18	type of tariff - timeband 18 week end	Int	0	0	2	NoUnits	ReadWrite
HoldingRegister	5045	1	trfw_19	type of tariff - timeband 19 week end	Int	0	0	2	NoUnits	ReadWrite
HoldingRegister	5046	1	trfw_20	type of tariff - timeband 20 week end	Int	0	0	2	NoUnits	ReadWrite
HoldingRegister	5047	1	trfw_21	type of tariff - timeband 21 week end	Int	0	0	2	NoUnits	ReadWrite
HoldingRegister	5048	1	trfw_22	type of tariff - timeband 22 week end	Int	0	0	2	NoUnits	ReadWrite
HoldingRegister	5049	1	trfw_23	type of tariff - timeband 23 week end	Int	0	0	2	NoUnits	ReadWrite
HoldingRegister	5050	1	tfr_active	current active Tariff	Int				NoUnits	ReadWrite
HoldingRegister	5104	1	GeneralMng.Year	Actual year	UInt		0	99	NoUnits	ReadWrite
HoldingRegister	5105	1	GeneralMng.Month	Actual month	UInt		0	99	NoUnits	ReadWrite
HoldingRegister	5106	1	GeneralMng.Day	Actual day	UInt		0	99	NoUnits	ReadWrite
HoldingRegister	5107	1	GeneralMng.Hour	Actual hour	UInt		0	99	NoUnits	ReadWrite
HoldingRegister	5108	1	GeneralMng.Minute	Actual minute	UInt		0	99	NoUnits	ReadWrite
HoldingRegister	5109	1	Mode	mode of unit (1=heat only 2=cool only 3=Auto)	Int	3	1	3	NoUnits	ReadWrite
HoldingRegister	5110	1	BMS_BMS_demand	BMS demand capacity	Int				NoUnits	ReadWrite
HoldingRegister	5111	1	BMS_BMS_PwrReq	BMS Maximum Power Request	Int				NoUnits	ReadWrite
HoldingRegister	5112	1	BMS_MaxPwrOffline	Maximum power when offline	Int				NoUnits	ReadWrite
HoldingRegister	5113	1	PwrLimOffDT	Offline delay	Int	120	15	300	Seconds	ReadWrite
HoldingRegister	5114	1	NightEndHr	Night Mode End Hour	Int	7	0	23	NoUnits	ReadWrite
HoldingRegister	5115	1	NightEndMin	Night Mode End Minute	Int	0	0	59	NoUnits	ReadWrite

HoldingRegister	5116	1	NightStartHr	Night Mode Start Hour	Int	20	0	23	NoUnits	ReadWrite
HoldingRegister	5117	1	NightStartMin	Night Mode Start Minute	Int	0	0	59	NoUnits	ReadWrite
HoldingRegister	5119	1	PmpStageDT	Pump Stage Delay Time to compressor	Int	5	0	99	Seconds	ReadWrite
HoldingRegister	5120	1	PmpStageOffDT	Pump Stage Off Delay Time	Int	60	0	999	Seconds	ReadWrite
HoldingRegister	5121	1	PmpBStageOffDT	Pump B Stage delay after Pump A	Int	30	0	999	Seconds	ReadWrite
HoldingRegister	5122	1	Pmp_Pulse	Variable Speed Pump Pulse duration on start	Int	5	0	30	Seconds	ReadWrite
HoldingRegister	5123	1	Blackout_DT	Delay time start up after blackout	Int	20	10	60	Seconds	ReadWrite
HoldingRegister	5124	1	CtrlSenSel	Controlling Sensor Selection	Int	0	0	CtrlSenSelLimit	NoUnits	ReadWrite
HoldingRegister	5125	1	PoolPrbSel	Pool probe selection	Int	0	0	PriorityPrbMax	NoUnits	ReadWrite
HoldingRegister	5126	1	CompStart_DT	Delay after Compressor request is sent to Safety block	Int	0	0	120	Seconds	ReadWrite
HoldingRegister	5127	1	HeatLPLockDT	LP lock out delay for Hesat Start	Int	180	5	600	Seconds	ReadWrite
HoldingRegister	5128	1	ElectrCompNo	Percentage of compressors in AL to force Electric	Int	50	0	100	NoUnits	ReadWrite
HoldingRegister	5129	1	BoostAct_DT	Active Boost Delay Time	Int	5	0	99	Minutes	ReadWrite
HoldingRegister	5130	1	PoolSpaPriority	0 = off; 1 = pool priority; 2 = spa priority;	Byte	0	0	2	NoUnits	ReadWrite
HoldingRegister	5131	1	PoolChgOver	Pool change over time	Int	30	15	300	Minutes	ReadWrite
HoldingRegister	5132	1	SpaChgOver	Spa change over time	Int	30	15	300	Minutes	ReadWrite
HoldingRegister	5136	1	UnitStatus	Unit status	UInt		0	9	NoUnits	ReadWrite
HoldingRegister	5141	1	PmpHRCnt	Pump hour run count	UInt				Hours	ReadWrite
HoldingRegister	5142	1	PmpBHRCnt	Pump B hour run count	UInt				Hours	ReadWrite
HoldingRegister	5143	1	Comp1HRCnt	Compressor 1 Hour run count	UInt				Hours	ReadWrite
HoldingRegister	5144	1	Comp2HRCnt	Compressor 2 Hour run count	UInt				Hours	ReadWrite
HoldingRegister	5145	1	Comp3HRCnt	Compressor 3 Hour run count	UInt				Hours	ReadWrite
HoldingRegister	5146	1	Comp4HRCnt	Compressor 4 Hour run count	UInt				Hours	ReadWrite
HoldingRegister	5147	1	Comp5HRCnt	Compressor 5 Hour run count	UInt				Hours	ReadWrite
HoldingRegister	5148	1	Comp6HRCnt	Compressor 6 Hour run count	UInt				Hours	ReadWrite

HoldingRegister	5149	1	OdoorFan1HRCnt	Outdoor fan 1 Hour run count	UInt				Hours	ReadWrite
HoldingRegister	5150	1	OdoorFan2HRCnt	Outdoor fan 2 Hour run count	UInt				Hours	ReadWrite
HoldingRegister	5151	1	OdoorFan3HRCnt	Outdoor fan 3 Hour run count	UInt				Hours	ReadWrite
HoldingRegister	5152	1	OdoorFan4HRCnt	Outdoor fan 4 Hour run count	UInt				Hours	ReadWrite
HoldingRegister	5153	1	OdoorFan5HRCnt	Outdoor fan 5 Hour run count	UInt				NoUnits	ReadWrite
HoldingRegister	5154	1	OdoorFan6HRCnt	Outdoor fan 6 Hour run count	UInt				NoUnits	ReadWrite
HoldingRegister	5155	1	PmpHRCntThrsh	Pump hour run count threshold	UInt	10000	0	65000	Hours	ReadWrite
HoldingRegister	5156	1	PmpBHRcntThrsh	Pump B hour run count threshold	UInt	10000	0	65000	Hours	ReadWrite
HoldingRegister	5157	1	Comp1HRCntThrsh	Compressor 1 Hour run threshold	UInt	10000	0	65000	Hours	ReadWrite
HoldingRegister	5158	1	Comp2HRCntThrsh	Compressor 2 Hour run threshold	UInt	10000	0	65000	Hours	ReadWrite
HoldingRegister	5159	1	Comp3HRCntThrsh	Compressor 3 Hour run threshold	UInt	10000	0	65000	Hours	ReadWrite
HoldingRegister	5160	1	Comp4HRCntThrsh	Compressor 4 Hour run threshold	UInt	10000	0	65000	Hours	ReadWrite
HoldingRegister	5161	1	Comp5HRCntThrsh	Compressor 5 Hour run threshold	UInt	10000	0	65000	Hours	ReadWrite
HoldingRegister	5162	1	Comp6HRCntThrsh	Compressor 6 Hour run threshold	UInt	10000	0	65000	Hours	ReadWrite
HoldingRegister	5163	1	OdoorFan1HRCntThrsh	Outdoor fan 1 Hour run threshold	UInt	10000	0	65000	Hours	ReadWrite
HoldingRegister	5164	1	OdoorFan2HRCntThrsh	Outdoor fan 2 Hour run threshold	UInt	10000	0	65000	Hours	ReadWrite
HoldingRegister	5165	1	OdoorFan2HRCntThrsh	Outdoor fan 2 Hour run threshold	UInt	10000	0	65000	Hours	ReadWrite
HoldingRegister	5166	1	OdoorFan4HRCntThrsh	Outdoor fan 4 Hour run threshold	UInt	10000	0	65000	Hours	ReadWrite
HoldingRegister	5167	1	OdoorFan5HRCntThrsh	Outdoor fan 5 Hour run threshold	UInt	10000	0	65000	NoUnits	ReadWrite
HoldingRegister	5168	1	OdoorFan6HRCntThrsh	Outdoor fan 6 Hour run threshold	UInt	10000	0	65000	NoUnits	ReadWrite
HoldingRegister	5169	1	Frost_DT	Frost Activation delay	Int	5	0	99	Minutes	ReadWrite
HoldingRegister	5170	1	De_ice_Init_time	de-ice initialisation cumulative time	Int	5	0	99	Minutes	ReadWrite
HoldingRegister	5171	1	de_ice_DT_MinRub	Comp min run time before defrost	Int	20	0	999	Minutes	ReadWrite
HoldingRegister	5172	1	De_ice_Max	Maximum duration of a de-ice cycle	Int	15	0	999	Minutes	ReadWrite
HoldingRegister	5173	1	De_ice_DT_OnOn	Delay between 2 consecutive de-ice cycles	Int	30	0	999	Minutes	ReadWrite

HoldingRegister	5174	1	De_Ice_DeW	Fan only coil de-water Delay Time	Int	30	0	999	Seconds	ReadWrite
HoldingRegister	5175	1	De_IceLPLOCKDT	LP lock out delay after De Ice finish	Int	300	5	600	Seconds	ReadWrite
HoldingRegister	5176	1	PmpMinOn	Pump Minimum on time	Int	300	0	999	Seconds	ReadWrite
HoldingRegister	5177	1	Pmp_Run_On	Pump run on time delay	Int	180	0	999	Seconds	ReadWrite
HoldingRegister	5178	1	BMS_PumpSpeedFlt		Int				NoUnits	ReadWrite
HoldingRegister	5179	1	PmpCycleT	Pump cycle time for temperature testinf (0.5 hour increments)	Int	4	1	10	Hours	ReadWrite
HoldingRegister	5180	1	PmpBMinOn	Pump B Minimum on time	Int	300	0	999	Seconds	ReadWrite
HoldingRegister	5181	1	PmpB_Run_On	Pump run on time delay (cold pump)	Int	180	0	999	Seconds	ReadWrite
HoldingRegister	5182	1	PmpBStageDT	Pump B Stage Delay Time to Pump A	Int	10	0	99	Seconds	ReadWrite
HoldingRegister	5183	1	Flw_Recheck	Time delay for Flow Re Checking	Int	180	0	999	Seconds	ReadWrite
HoldingRegister	5184	1	Flw_Proof_DT	Flow Proof Delay	Int	30	0	30	Seconds	ReadWrite
HoldingRegister	5185	1	FlwDT_Off	Off delay when flow switch used for on/off	Int	2	1	6	Seconds	ReadWrite

## To Turn Off the Water Heater

If it is necessary to turn off the water heater on completion of the installation, such as on a building site or where the premises are vacant, then:

- Switch off the electrical supply at the isolating switch to the water heater.
- Close the cold water isolation valve at each inlet to the water heater.

# DRAINING THE WATER HEATER

To drain the water heater:

- Turn off the water heater (refer to “To Turn Off The Water Heater” on **page 71**).
- Close all hot water taps.
- Operate the relief valve release lever on one of the storage tanks - do not let the lever snap back or you will damage the valve seat.  
Operating the lever will release the pressure in the water heater.
- Close the isolation valves at the inlets and outlets of the water heater (cold and hot side) and place a bucket under each inlet side.
  - Undo the unions at the inlets and outlets of the water heater. The heat pump heat exchanger holds 5 litres of water and will drain into the bucket.

# TROUBLE SHOOTING

- **Heat Pump Won't Start**

A delay of up to 20 minutes can be experienced before heat pump starts operating

- **Incorrect Phase Rotation**



PHASE  
DETECT  
RELAY



The phase detect relay will open circuit if the heat pump has been wired with incorrect phase rotation or if a phase has failed. Both **green and yellow** LEDs on the relay will be illuminated if phase rotation is correct.

- **Alarm light on heat pump controller**

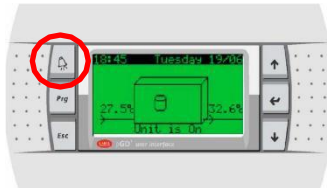

If the alarm light is flashing RED, check the alarm by pressing the alarm button. Phone your nearest Rheem Service Department or Accredited Service Agent (or Service Centre in NZ) to inform about the alarm.

- **Activation of Freeze Protection**

Check the control panel of the heat pump. Read the error message/ warning if it shows on the display.

- **Heat pump starts then turns off soon after**

This could be caused by:

- a. Insufficient water flow rate through heat exchanger. Check pipe sizing per chart, check obstructions, check lines and pump are bled, check pump is operating.

**Note:** Tanks and heat pumps are to be manifolded in Equa-Flow. It is important that the branches to each storage tank **ONLY** contain a gate or ball valve and union. Fitting of loose jumper valves, non-return valves or pressure limiting valves in the branches or primary flow and return lines between the heat pump and tanks **WILL** affect performance of the heat pump.

b. Refrigerant charge too high

c. Refrigerant charge too low?

Turn heat pump off then on again at isolating switch to reset system.

- **Heat pump compressor excessively noisy**  
Check for correct phase rotation (refer to [page 71](#)).

# **RHEEM HEAT PUMP WATER HEATER WARRANTY -AUSTRALIA & NEW ZEALAND ONLY -**

## **HEAT PUMP WATER HEATER MODELS 95402000, 95404500, 9540200S, 9540450S**

### **1. THE RHEEM WARRANTY – GENERAL**

- 1.1 This warranty is given by Rheem Australia Pty Limited ABN 21 098 823 511 of 1 Alan Street, Rydalmere New South Wales.
- 1.2 Rheem offer a trained and qualified national service network who will repair or replace components at the address of the water heater subject to the terms of the Rheem warranty. Rheem Service, in addition can provide preventative maintenance and advice on the operation of your water heater. The Rheem Service contact number is 131031, with Contact Centre personnel available 24 hours, 7 days a week to take your call and if necessary to arrange a service call for during normal working hours Monday to Friday (hours subject to change).
- 1.3 For details about this warranty, you can contact us on 131 031 or by email at [warrantyenquiry@rheem.com.au](mailto:warrantyenquiry@rheem.com.au) (not for service bookings) and for New Zealand on 0800 657 335.
- 1.4 The terms of this warranty and what is covered by it are set out in section 2 and apply to water heaters manufactured after 1<sup>st</sup> July 2019.
- 1.5 If a subsequent version of this warranty is published, the terms of that warranty and what is covered by it will apply to water heaters manufactured after the date specified in the subsequent version.

### **2. TERMS OF THE RHEEM WARRANTY AND EXCLUSIONS TO IT**

- 2.1 The decision of whether to repair or replace a faulty component is at Rheem's sole discretion.
- 2.2 Where a failed component or cylinder is replaced under this warranty, the balance of the original warranty period will remain effective. The replacement does not carry a new Rheem warranty.
- 2.3 Where the water heater is installed outside the boundaries of a metropolitan area as defined by Rheem or further than 25 km from either a regional Rheem branch office or an Accredited Rheem Service Agent's office, the cost of transport, insurance and travelling between the nearest branch office or Rheem Accredited Service Agent's office and the installed site shall be the owner's responsibility.
- 2.4 Where the water heater is installed in a position that does not allow safe or ready access, the cost of that access, including the cost of additional materials handling and/or safety equipment, shall be the owner's responsibility. In other words, the cost of dismantling or removing cupboards, doors or walls and the cost of any special equipment to bring the water heater to floor or ground level or to a serviceable position is not covered by this warranty.
- 2.5 This warranty only applies to the original and genuine Rheem water heater in its original installed location and any genuine Rheem replacement parts.
- 2.6 If the water heater is not sized to supply the hot water demand in accordance with the guidelines in Rheem's water heater literature, any resultant fault will not be covered by Rheem's warranty.
- 2.7 The Rheem warranty does not cover faults that are a result of:
  - a) Accidental damage to the water heater or any component (for example: (i) Acts of God such as floods, storms, fires, lightning strikes and the like; and (ii) third party acts or omissions).
  - b) Misuse or abnormal use of the water heater.
  - c) Installation not in accordance with the Owner's Guide and Installation Instructions or with relevant statutory and local requirements in the State or Territory in which the water heater is installed.

# **RHEEM HEAT PUMP WATER HEATER WARRANTY -AUSTRALIA & NEW ZEALAND ONLY -**

- d) Connection at any time to a water supply that does not comply with the water supply guidelines as outlined in the Owner's Guide and Installation Instructions.
  - e) Repairs, attempts to repair or modifications to the water heater by a person other than Rheem Service or a Rheem Accredited Service Agent.
  - f) Faulty plumbing or faulty power supply.
  - g) Failure to maintain the water heater in accordance with the Owner's Guide and Installation Instructions.
  - h) Transport damage.
  - i) Fair wear and tear from adverse conditions (for example, corrosion).
  - j) Cosmetic defects.
- 2.8 If you require a call out and we find that the fault is not covered by the Rheem warranty, you are responsible for our standard call out charge. If you wish to have the relevant component repaired or replaced by Rheem, that service will be at your cost.
- 2.9 Subject to any statutory provisions to the contrary, this warranty excludes any and all claims for damage to furniture, carpet, walls, foundations or any other consequential loss either directly or indirectly due to leakage from the water heater, or due to leakage from fittings and/ or pipe work of metal, plastic or other materials caused by water temperature, workmanship or other modes of failure.

### **3. WHAT IS COVERED BY THE RHEEM WARRANTY FOR THE WATER HEATERS DETAILED IN THIS DOCUMENT**

- 3.1 Rheem will repair or replace a faulty component of your water heater if it fails to operate in accordance with its specifications as follows:

What components are covered	The period in which the fault must appear in order to be covered	What coverage you receive
All components	Year 1	Repair and/or replacement of the faulty component, free of charge, including labour.
<b>Sealed System*</b> components	Year 2	Repair and/or replacement of the faulty component, free of charge, including labour.

\* The Sealed System includes components that carry refrigerant only, e.g. Compressor, Condenser, TX Valve, Receiver / Drier, Evaporator and associated pipe work.

### **4. ENTITLEMENT TO MAKE A CLAIM UNDER THIS WARRANTY**

- 4.1 To be entitled to make a claim under this warranty you need to:
- a) Be the owner of the water heater or have consent of the owner to act on their behalf
  - b) Contact Rheem Service without undue delay after detection of the defect and, in any event, within the applicable warranty period.
- 4.2 You are **not** entitled to make a claim under this warranty if your water heater:
- a) Does not have its original serial numbers or rating labels.
  - b) Is not installed in Australia.

# **RHEEM HEAT PUMP WATER HEATER WARRANTY -AUSTRALIA & NEW ZEALAND ONLY -**

## **5. HOW TO MAKE A CLAIM UNDER THIS WARRANTY**

- 5.1 If you wish to make a claim under this warranty, you need to:
- a) Contact Rheem on 131031 (for Australia) or 0800 657 335 (for New Zealand) and provide owner's details, address of the water heater, a contact number and date of installation of the water heater or if that's unavailable, the date of manufacture and serial number (from the rating label on the water heater)
  - b) Rheem will arrange for the water heater to be tested and assessed on-site.
  - c) If Rheem determines that you have a valid warranty claim, Rheem will repair or replace the water heater in accordance with this warranty
- 5.2 Any expenses incurred in the making of a claim under this warranty will be borne by you.

## **6. THE AUSTRALIAN CONSUMER LAW**

- 6.1 Our goods come with guarantees that cannot be excluded under the *Australian Consumer Law*. You are entitled to a replacement or refund for a major failure and for compensation for any other reasonably foreseeable loss or damage. You are also entitled to have the goods repaired or replaced if the goods fail to be of acceptable quality and the failure does not amount to a major failure.
- 6.2 The Rheem warranty (set out above) is in addition to any rights and remedies that you may have under the *Australian Consumer Law*.

**RHEEM AUSTRALIA PTY LTD**  
A.B.N. 21 098 823 511  
[www.rheem.com.au](http://www.rheem.com.au)

FOR SERVICE TELEPHONE  
**131 031 AUSTRALIA**  
**0800 657 335 NEW ZEALAND**