

Owner's Guide and Installation Instructions



RJ Heavy Duty Stainless Steel Storage Tank



Install a Rheem

*This storage tank must be installed and serviced by a qualified person.
Please leave this guide with the householder and/or responsible officer.*



WARNING: Plumber – Be Aware

This water heater must be installed in compliance with the Plumbing Code of Australia (PCA).

- For the continued safety of this appliance, it must be installed, operated and maintained in accordance with the manufacturer's instructions.
- **Warning:** This appliance may deliver water at high temperature. Refer to the Plumbing Code of Australia (PCA), local requirements and installation instructions to determine if additional delivery temperature control is required.
- The primary flow and return pipes between the storage tank(s) and the primary water heating source, including the solar hot and solar cold pipes between the solar storage tank(s) and the solar collectors, **MUST BE** of copper or metallic pipe. All compression fittings must use brass or copper olives.
- The full length of the primary flow and return pipes **MUST BE** insulated.

The insulation must:

- be of a type suitable for the application and capable of withstanding the temperature of the water generated by the primary water heating source

The specification of the chosen insulation material should be checked with the insulation manufacturer prior to installation as different materials may vary in temperature tolerance.

- be at least 13 mm thick, however thicker insulation may be required to comply with the requirements of AS/NZS 3500.4
- be weatherproof and UV resistant if exposed.
- be fitted up to and cover the connections on both the storage tank(s) and the primary heating source.

The insulation will reduce pipe heat losses and also assist in avoiding accidental contact with the pipe work as high temperature water can flow from the primary heating source and the storage tank(s).

In addition, the insulation on the solar hot and solar cold pipes must also:

- extend through any penetrations in the eaves, ceiling and roof.
- cover valves and fittings in the solar hot and solar cold pipe work

Note: Failure to observe these requirements also increases the risk of freeze damage.

The insulation is essential to assist in providing freeze protection and will offer corrosion protection to a metal roof against water runoff over the copper pipe.

Uninsulated pipe work, including concealed in cavities and roof spaces or where it may be in contact with a metal roof, may lead to freeze damage. The system has NO WARRANTY for freeze damage if the solar hot and solar cold pipes are not insulated in accordance with the installation instructions.

Plumber: It is important to refer to and read in full the complete "Warning: Plumber – Be Aware" statement commencing on page 23.

PATENTS

This storage tank may be protected by one or more patents or registered designs in the name of Rheem Australia Pty Ltd.

TRADEMARKS

© Registered trademark of Rheem Australia Pty Ltd.
™ Trademark of Rheem Australia Pty Ltd.

Note: Every care has been taken to ensure the accuracy in preparation of this publication. No liability can be accepted for any consequences, which may arise as a result of its publication.

CONTENTS

RESPONSIBLE OFFICER - We recommend you read pages 6 - 14.
The other pages are intended for the installer but may be of interest.

Contents	3
Rheem Australia Storage Tank Warranty	4
About Your Storage Tank	6
Regular Care	9
Water Supplies.....	11
Save A Service Call	14
Installation.....	15
Connections – Plumbing	20
Multiple Installations	24
Connections – Electrical.....	32
Commissioning.....	33
Draining The Storage Tank.....	34
Lifting The Tank.....	35

*This storage tank must be installed and serviced by a qualified person.
Please leave this guide with the householder and/or responsible officer.*

RHEEM AUSTRALIA STORAGE TANK WARRANTY

STORAGE TANK MODEL: RJ1050N80

1. THE RHEEM WARRANTY – GENERAL

- 1.1 This warranty is given by Rheem Australia Pty Limited ABN 21 098 823 511 of 1 Alan Street, Rydalmere New South Wales.
- 1.2 Rheem offer a trained and qualified national service network who will repair or replace components at the address of the storage tank subject to the terms of the Rheem warranty. Rheem Service, in addition can provide preventative maintenance and advice on the operation of your storage tank. The Rheem Service contact number is available 7 days a week on 131031 with Service personnel available to take your call from 8am to 8pm daily (hours subject to change).
- 1.3 For details about this warranty, you can contact us on 131031 or by email at warrantyenquiry@rheem.com.au (not for service bookings).
- 1.4 The terms of this warranty and what is covered by it are set out in sections 2 and 3 and apply to storage tanks manufactured after 1st June 2015.
- 1.5 If a subsequent version of this warranty is published, the terms of that warranty and what is covered by it will apply to storage tanks manufactured after the date specified in the subsequent version.

2. TERMS OF THE RHEEM WARRANTY AND EXCLUSIONS TO IT

- 2.1 The decision of whether to repair or replace a faulty component is at Rheem's sole discretion.
- 2.2 If you require a call out and we find that the fault is not covered by the Rheem warranty, you are responsible for our standard call out charge. If you wish to have the relevant component repaired or replaced by Rheem, that service will be at your cost.
- 2.3 Where a failed component or cylinder is replaced under this warranty, the balance of the original warranty period will remain effective. The replacement does not carry a new Rheem warranty.
- 2.4 Where the storage tank is installed outside the boundaries of a metropolitan area as defined by Rheem or further than 25 km from either a regional Rheem branch office or an Accredited Rheem Service Agent's office, the cost of transport, insurance and travelling between the nearest branch office or Rheem Accredited Service Agent's office and the installed site shall be the owner's responsibility.
- 2.5 Where the storage tank is installed in a position that does not allow safe or ready access, the cost of that access, including the cost of additional materials handling and/or safety equipment, shall be the owner's responsibility. In other words, the cost of dismantling or removing cupboards, doors or walls and the cost of any special equipment to bring the storage tank to floor or ground level or to a serviceable position is not covered by this warranty.
- 2.6 This warranty only applies to the original and genuine Rheem storage tank in its original installed location and any genuine Rheem replacement parts.
- 2.7 The Rheem warranty does not cover faults that are a result of:
 - a) Accidental damage to the storage tank or any component (for example: (i) Acts of God such as floods, storms, fires, lightning strikes and the like; and (ii) third party acts or omissions).
 - b) Misuse or abnormal use of the storage tank.
 - c) Installation not in accordance with the Owner's Guide and Installation Instructions or with relevant statutory and local requirements in the State or Territory in which the storage tank is installed.
 - d) Connection at any time to a water supply that does not comply with the water supply guidelines as outlined in the Owner's Guide and Installation Instructions.
 - e) Repairs, attempts to repair or modifications to the storage tank by a person other than Rheem Service or a Rheem Accredited Service Agent.
 - f) Faulty plumbing or faulty power supply.
 - g) Failure to maintain the storage tank in accordance with the Owner's Guide and Installation Instructions.
 - h) Transport damage.
 - i) Fair wear and tear from adverse conditions (for example, corrosion).
 - j) Cosmetic defects.
- 2.8 Subject to any statutory provisions to the contrary, this warranty excludes any and all claims for damage to furniture, carpet, walls, foundations or any other consequential loss either directly or indirectly due to leakage from the storage tank, or due to leakage from fittings and/ or pipe work of metal, plastic or other materials caused by water temperature, workmanship or other modes of failure.
- 2.9 If the storage tank is not sized to supply the hot water demand in accordance with the guidelines in the Rheem storage tank literature, any resultant fault will not be covered by the Rheem warranty.

PATENTS

This storage tank may be protected by one or more patents or registered designs in the name of Rheem Australia Pty Ltd.

TRADEMARKS

© Registered trademark of Rheem Australia Pty Ltd.
™ Trademark of Rheem Australia Pty Ltd.

Note: Every care has been taken to ensure the accuracy in preparation of this publication. No liability can be accepted for any consequences, which may arise as a result of its publication.

RHEEM AUSTRALIA STORAGE TANK WARRANTY

STORAGE TANK MODEL: RJ1050N80

3. WHAT IS COVERED BY THE RHEEM WARRANTY FOR THE STORAGE TANKS DETAILED IN THIS DOCUMENT

3.1 Rheem will repair or replace a faulty component of your storage tank if it fails to operate in accordance with its specifications as follows:

What components are covered	The period from the date of installation in which the fault must appear in order to be covered	What coverage you receive
All components	Year 1	Repair and/or replacement of the faulty component, free of charge, including labour.
The cylinder	Years 2 to 5	Repair and / or replacement of the cylinder, free of charge, including labour.
	Years 6 to 8	Replacement cylinder, free of charge. Installation and repair labour costs are the responsibility of the owner.

4. ENTITLEMENT TO MAKE A CLAIM UNDER THIS WARRANTY

- 4.1 To be entitled to make a claim under this warranty you need to:
- Be the owner of the storage tank or have consent of the owner to act on their behalf.
 - Contact Rheem Service without undue delay after detection of the defect and, in any event, within the applicable warranty period.
- 4.2 You are **not** entitled to make a claim under this warranty if your storage tank:
- Does not have its original serial numbers or rating labels.
 - Is not installed in Australia.

5. HOW TO MAKE A CLAIM UNDER THIS WARRANTY

- 5.1 If you wish to make a claim under this warranty, you need to:
- Contact Rheem on 131031 and provide owner's details, address of the storage tank, a contact number and date of installation of the storage tank or if that's unavailable, the date of manufacture and serial number (from the rating label on the storage tank).
 - Rheem will arrange for the storage tank to be tested and assessed on-site.
 - If Rheem determines that you have a valid warranty claim, Rheem will repair or replace the storage tank in accordance with this warranty.
- 5.2 Any expenses incurred in the making of a claim under this warranty will be borne by you.

6. THE AUSTRALIAN CONSUMER LAW

- 6.1 Our goods come with guarantees that cannot be excluded under the *Australian Consumer Law*. You are entitled to a replacement or refund for a major failure and for compensation for any other reasonably foreseeable loss or damage. You are also entitled to have the goods repaired or replaced if the goods fail to be of acceptable quality and the failure does not amount to a major failure.
- 6.2 The Rheem warranty (set out above) is in addition to any rights and remedies that you may have under the *Australian Consumer Law*.

RHEEM AUSTRALIA PTY LTD, A.B.N. 21 098 823 511, www.rheem.com.au
For Service Telephone 131 031 AUSTRALIA or 0800 657 335 NEW ZEALAND

ABOUT YOUR STORAGE TANK

STORAGE TANK APPLICATION

This storage tank is designed for the purpose of storing heated potable water. Its use in an application other than this may shorten its life.

This water heater complies with the Lead Free requirements of the National Construction Code Volume Three.

MODEL TYPE

The Rheem® Commercial hot water storage tank you have chosen can be installed indoors or outdoors.

Water is stored in a stainless-steel cylinder and heated by an external primary heating source. The temperature is controlled by the thermostat(s) on the heating source. Automatic safety controls must be fitted to the primary heating source to provide safe and efficient operation.

MAINS PRESSURE

The storage tank is designed to operate at mains pressure by connecting directly to the mains water supply. If the mains supply pressure in your area exceeds that shown on **page 16**, a pressure limiting valve must be fitted. The supply pressure should be greater than 350 kPa for true mains pressure operation to be achieved.

HOW HOT SHOULD THE WATER BE?

The storage tank is designed for a maximum allowable water temperature of 80°C. Refer to the installation instructions supplied with the primary heating source plant for further information on water temperatures.

Note: Australian Standard AS 3498 and New Zealand Building Code Clause G12 requires that a water heater provides the means to inhibit the growth of Legionella bacteria in potable water.

If this storage tank is installed as part of a solar water heater to an in-series storage water heater, then these AS 3498 and Clause G12 requirements can be satisfied provided the storage water heater is energised and the thermostat setting is 60°C or higher.

If this storage tank is installed as part of a solar water heater to an in-series continuous flow gas booster, then these AS 3498 and Clause G12 requirements can be satisfied provided the booster is energised, its preset outlet temperature setting is 70°C or higher and a remote temperature controller is not used.

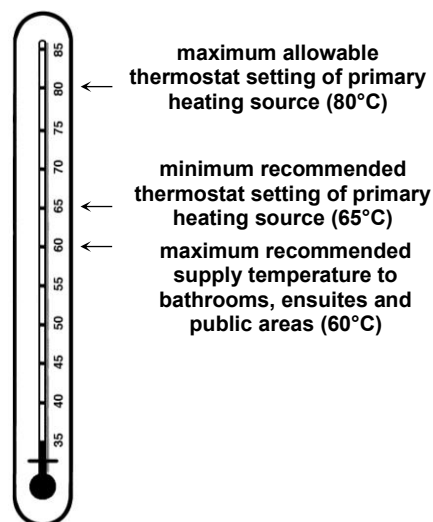

HOTTER WATER INCREASES THE RISK OF SCALD INJURY.

This storage tank can deliver water at temperatures which can cause scalding. Check the water temperature before use, such as when entering a shower or filling a bath or basin, to ensure it is suitable for the application and will not cause scald injury.

We recommend and it may also be required by regulations that an approved temperature limiting device be fitted into the hot water pipe work to the bathing and public areas when this storage tank is installed. This will keep the water temperature below 50°C or the maximum permitted by AS/NZS 3500.4 to these areas. The risk of scald injury will be reduced and still allow hotter water to the kitchen, laundry and other areas requiring sanitising temperatures.

TEMPERATURE ADJUSTMENT

We advise the thermostats of the primary heating plant are adjusted to the lowest temperature setting that meets your needs, especially if there are young children or elderly people in the premises, but they should not be set to less than 60°C. Refer to “Hotter Water Increases the Risk of Scald Injury” on **page 6**.

⚠ WARNING

This storage tank is only intended to be operated by persons who have the experience or the knowledge and the capabilities to do so. This storage tank is not intended to be operated by persons with reduced physical, sensory or mental capabilities i.e. the infirm, or by children. Children should be supervised to ensure they do not interfere with the storage tank.

SAFETY

The storage tank is supplied with temperature and pressure relief. In addition, the heating source connected to the storage tank may also have temperature and pressure relief. The valve(s) must not be tampered with or removed. The storage tank and its primary heating source must not be operated unless each of these devices is fitted and is in working order.

If a remote thermostat (Tankstat) is fitted to the storage tank and the electrical conduit is damaged, it must be replaced by a qualified person in order to avoid a hazard. Phone Rheem Service or their nearest Accredited Service Agent to arrange for an inspection.

⚠ Warning: For continued safety of this water heating system it must be installed, operated and maintained in accordance with the Owner's Guide and Installation Instructions.

The Rheem warranty may not cover faults if relief valves or other safety devices are tampered with or if the installation is not in accordance with these instructions.

PRECAUTIONS

Where damage to property can occur in the event of the storage tank leaking, the storage tank must be installed in a safe tray. Construction, installation and draining of a safe tray must comply with AS/NZS 3500.4 and all local codes and regulatory authority requirements.

The storage tank must be maintained in accordance with the Owner's Guide and Installation Instructions. Refer to "Regular Care" on page 9.

If this storage tank is to be used where an uninterrupted hot water supply is necessary for your application or business, you should ensure that you have back up redundancy within the hot water system design. This should ensure the continuity of hot water supply in the event that this storage tank were to become inoperable for any reason. We recommend you seek advice from your plumber or specifier about your needs and building back up redundancy into your hot water supply system.

Where booster pump sets are used, damping must be incorporated to prevent cyclic water hammer acting on the cylinder. **Any resultant faults to the cylinder due to water hammer will not be covered by the Rheem warranty.**

TO TURN OFF THE STORAGE TANK

If it is necessary to turn off the storage tank:

- Turn off the primary water heating plant and switch off the electrical supply at the isolating switch to the circulating pump(s).
- Close the cold water isolation valve on the cold water line to the storage tank(s) to shut down the entire system, or;
- Close the isolation valves on the cold, flow / return and hot water branches to shut down an individual storage tank in a bank.

TO TURN ON THE STORAGE TANK

- Open the isolation valves fully on the cold, flow / return and hot water branches to the storage tank(s) installed in a bank.
- Open the cold water isolation valve on the cold water line to the storage tank(s). Air will be forced out of the taps.
- Switch on the electrical supply at the isolating switch to the circulating pump(s) and turn on the primary water heating plant.

HOW DO I KNOW IF THE STORAGE TANK IS INSTALLED CORRECTLY?

Installation requirements are shown on pages 15 to 22 and 24 to 31. The storage tank must be installed:

- by a qualified person, and
- in accordance with the installation instructions, and
- in compliance with Standard AS/NZS 3500.4 and all local codes and regulatory authority requirements.

In New Zealand the installation must also conform with the New Zealand Building Code.

VICTORIAN CUSTOMERS

Notice to Victorian Customers from the Victorian Plumbing Industry Commission. This storage tank must be installed by a licensed person as required by the Victorian Building Act 1993.

Only a licensed person will give you a Compliance Certificate, showing that the work complies with all the relevant Standards. Only a licensed person will have insurance protecting their workmanship for 6 years. Make sure you use a licensed person to install this storage tank and ask for your Compliance Certificate.

DOES THE WATER CHEMISTRY AFFECT THE STORAGE TANK?

The storage tank is suitable for most public water supplies, however some water chemistries may have detrimental effects on the storage tank, its components and fittings. Refer to "Water Supplies" on page 11.

If you are in a known harsh water area or you are not sure of your water chemistry, have your water checked against the conditions described on pages 11 to 13.

HOW LONG WILL THE STORAGE TANK LAST?

The storage tank is supported by a manufacturer's warranty (refer to page 4). There are a number of factors that will affect the length of service the storage tank will provide. These include but are not limited to the water chemistry, the water pressure, the water temperature (inlet and outlet) and the water usage pattern. Refer to "Precautions" on page 7.

REGULAR CARE

MINOR SIX MONTH MAINTENANCE

It is recommended minor maintenance be performed every six months by a responsible officer.

The minor maintenance includes:

- Operate the easing lever on the temperature pressure relief valve. It is very important you raise and lower the lever gently. Refer to "Temperature Pressure Relief Valve" on page 10.
⚠ Warning: Exercise care to avoid any splashing of water, as water discharged from the drain line will be hot. Stand clear of the drain line's point of discharge when operating the valve's lever.
- Operate the easing lever on the expansion control valve (if fitted). It is very important you raise and lower the lever gently. Refer to "Expansion Control Valve" on page 10.
- Check the drain line from the safe tray (if one is installed) is not blocked.

MAJOR FIVE YEAR SERVICE

It is recommended a major five year service be conducted on the storage tank. The service must be conducted by a qualified person. Phone Rheem Service or their nearest Accredited Service Agent.

Note: The five year service and routine replacement of any components, such as the relief valve(s), are not included in the Rheem warranty. A charge will be made for this work. Only genuine replacement parts should be used on this storage tank.

The major service includes the following actions:

- Replace the temperature pressure relief valve.
- Inspect and flush the expansion control valve (if fitted). If required, replace the valve.
- Drain and flush the storage tank if required.

In commercial applications where large volumes of hot water are used, sediment may build up on the bottom of the cylinder. In extreme cases, particularly in areas of high water sediment, draining and flushing out may be necessary.

- Visually check the unit for any potential problems.
- Inspect all connections.
- Check the drain line from the safe tray (if one is installed) is not blocked.

Note: The storage tank may need to be drained during this service. After the completion of the service, the water heater will take some time to reheat the water. Depending upon the heating source, hot water may not be available for a while.

TEMPERATURE PRESSURE RELIEF VALVE

This valve is near the top of the storage tank and is essential for its safe operation. It is possible for the valve to release a little water through the drain line during each heating period. This occurs as the water is heated and expands by approximately 1/50 of its volume.

Continuous leakage of water from the valve and its drain line may indicate a problem with the water heater (refer to “Temperature Pressure Relief Valve Running” on page 14).

⚠ Warning: Never block the outlet of this valve or its drain line for any reason.

Operate the easing lever on the temperature pressure relief valve once every six months. Refer to “Minor Six Month Maintenance” on page 9. **It is very important the lever is raised and lowered gently.**

⚠ Warning: Failure to do this may result in the storage tank cylinder failing.

⚠ Warning: Exercise care to avoid any splashing of water, as water discharged from the drain line will be hot. Stand clear of the drain line’s point of discharge when operating the valve’s lever.

If water does not flow freely from the drain line when the lever is lifted, then the storage tank must be checked. Phone Rheem Service or their nearest Accredited Service Agent.

The temperature pressure relief valve should be replaced at intervals not exceeding 5 years, or more frequently in areas where there is a high incidence of water deposits (refer to “Water Supplies” on page 11).

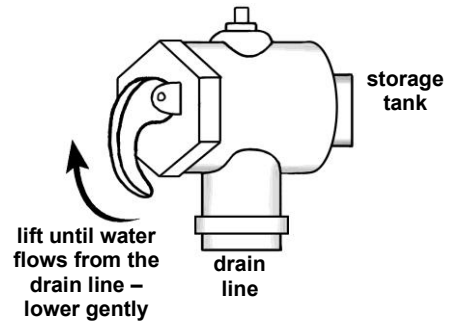

EXPANSION CONTROL VALVE

In many areas, including Queensland, South Australia, Western Australia and scaling water areas, it is mandatory an expansion control valve is fitted to the cold water line to the storage tank. The expansion control valve may discharge a small quantity of water from its drain line during the heating period instead of the temperature pressure relief valve on the storage tank.

Operate the easing lever on the expansion control valve once every six months. Refer to “Minor Six Month Maintenance” on page 9. **It is very important the lever is raised and lowered gently.** If water does not flow freely from the drain line when the lever is lifted, then the storage tank should be checked by Rheem Service or their nearest Accredited Service Agent. The expansion control valve should be checked for performance or replaced at intervals not exceeding 5 years, or more frequently in areas where there is a high incidence of water deposits.

WATER SUPPLIES

This storage tank must be installed in accordance with this advice to be covered by the Rheem warranty.

This storage tank is manufactured to suit the water conditions of most public reticulated water supplies. However, there are some known water chemistries which can have detrimental effects on the storage tank and its operation and / or life expectancy.

A list of postcodes is available on the Rheem website (www.rheem.com.au) indicating known areas where the stainless steel cylinder is not covered by the Rheem warranty due to the water chemistry of the area. The list is not necessarily exhaustive and there may be areas outside of these postcodes where the stainless steel cylinder is not covered by the Rheem warranty due to the water chemistry of the area.

If you are unsure of your water chemistry, you may be able to obtain information from your local water supply authority. This storage tank should only be connected to a water supply which complies with these guidelines, which takes precedence over the list of postcodes, for the Rheem warranty to apply.

It is recommended to install a suitable filter on the cold water supply line to the storage tank if the water supply contains or has a future risk of containing suspended solids. The Rheem warranty will not cover resultant faults on components including the stainless steel cylinder due to the effects of sludge and / or sediment settling in the storage tank.

CHANGE OF WATER SUPPLY

The changing or alternating from one water supply to another can have a detrimental effect on the operation and / or life expectation of a storage tank cylinder and a temperature pressure relief valve.

Where there is a changeover from one water supply to another, e.g., a rainwater tank supply, bore water supply, desalinated water supply, public reticulated water supply or water brought in from another supply, then water chemistry information should be sought from the supplier or it should be tested to ensure the water supply meets the requirements given in these guidelines for the Rheem warranty to apply.

CHLORIDE AND PH

In a high chloride and sulphate water supply, the water can corrode stainless steel parts and cause them to fail.

The stored water temperature also affects the level of chloride and sulphate that the stainless steel cylinder can withstand. Where the chloride and sulphate levels exceed the numbers listed in the below table for the given water temperature, the Rheem warranty does not apply to a stainless steel cylinder.

	up to 60 °C	60-70 °C	up to and including 80 °C
Chlorides (Cl ⁻)	≤250 mg/L	≤200 mg/L	≤150 mg/L
Sulphates (SO ₄ ²⁻)	≤250 mg/L	≤200 mg/L	≤150 mg/L

pH is a measure of whether the water is alkaline or acidic. In an acidic or very alkaline water supply, the water can attack stainless steel parts and cause them to fail.

Where the pH is less than 6.0 or greater than 9.5, the Rheem warranty does not apply to a stainless steel cylinder. Water with a pH less than 6.0 may be treated to raise the pH.

The water supply from a rainwater tank in a metropolitan area is likely to be corrosive due to the dissolution of atmospheric contaminants. This may result in pH of less than 6.0. It is recommended an analysis on the water from a rainwater tank be conducted prior to connecting this type of water supply to a storage tank with a stainless steel cylinder.

SATURATION INDEX

The saturation index (SI) is used as a measure of the water's corrosive or scaling properties. The saturation index figures stated are calculated using a water temperature of 80°C.

In a corrosive water supply, the water can attack copper parts and cause them to fail.

In a scaling water supply calcium carbonate is deposited out of the water onto any hot metallic surface.

Where the saturation index exceeds 0.40, the water is very scaling. An expansion control valve must be fitted on the cold water line after the non-return valve to protect and for the Rheem warranty to apply to the temperature pressure relief valve and storage tank cylinder.

Where the saturation index exceeds 0.80 or is less than -1.0, the Rheem warranty does not apply to a stainless steel cylinder.

Water which is scaling may be treated with a water softening device to reduce the saturation index of the water.

Refer to the Saturation Index chart on page 12.

Refer to the cold water connection diagram on page 20 for the position of the expansion control valve.

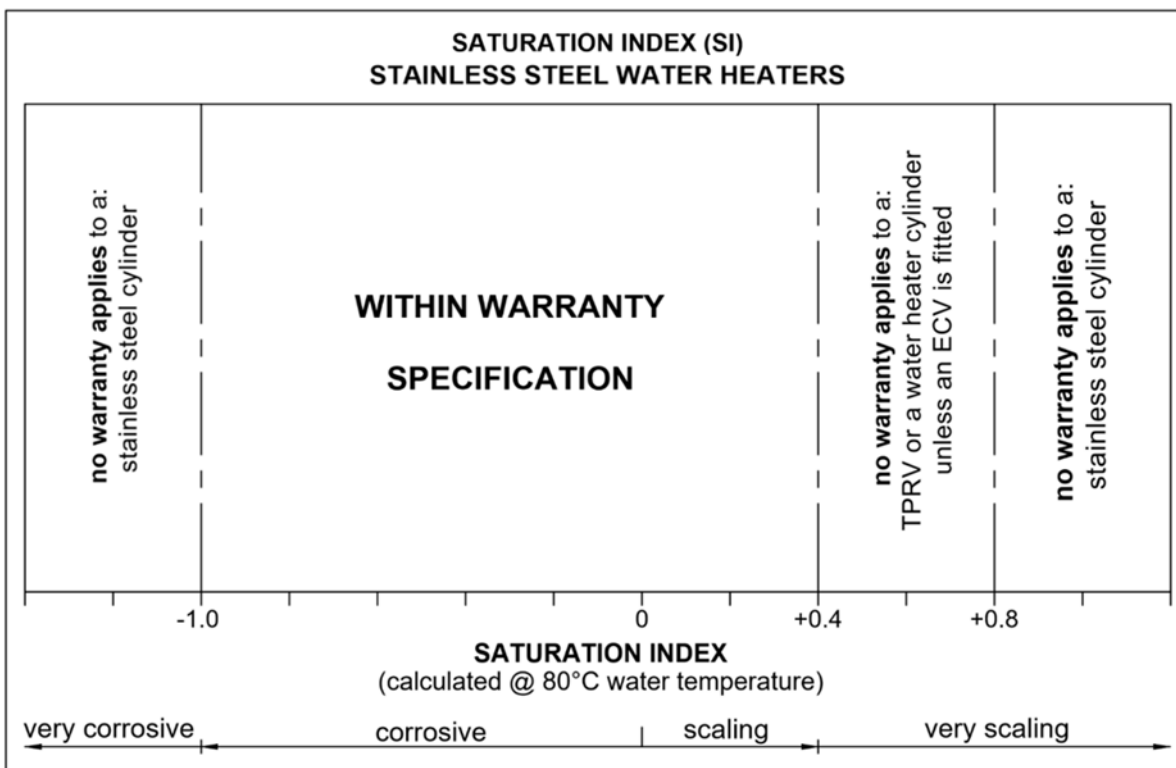

TOTAL DISSOLVED SOLIDS

The stainless steel cylinder is not covered by the Rheem warranty when the total dissolved solids (TDS) content in the water is greater than 600 mg / L.

Note: Some water analysis reports may state the conductivity of the water rather than the level of total dissolved solids. Conductivity, measured in microsiemens per centimetre ($\mu\text{S} / \text{cm}$), is directly proportional to the TDS content of the water. TDS, in mg / L, is approximately 70% of the conductivity in $\mu\text{S} / \text{cm}$.

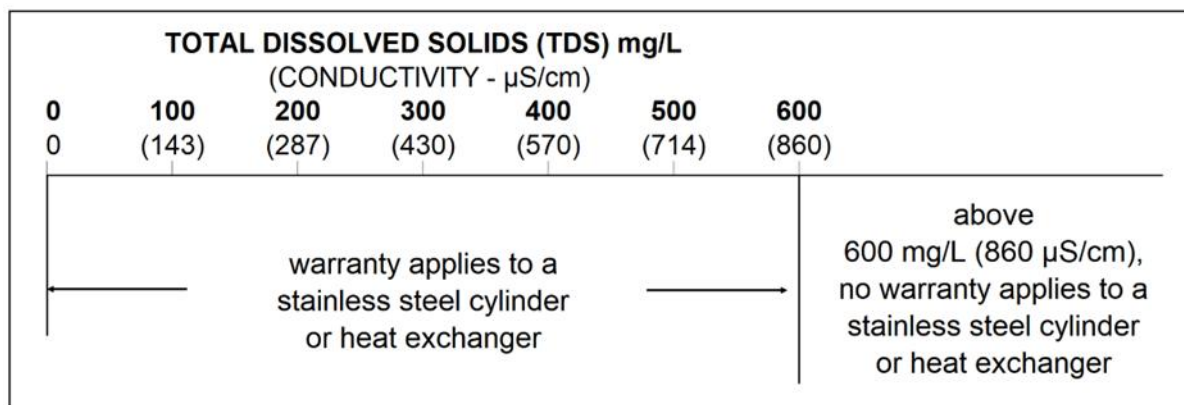

SUMMARY OF WATER CHEMISTRY ADVICE AFFECTING WARRANTY

The storage tank and its components are not suitable for certain water chemistries. Those chemistries are listed below. If the storage tank is connected at any time to a water supply with the following water chemistry, the Rheem warranty will not cover any resultant faults on the components listed below:

Water Chemistry	Component
Chloride and Sulphate > 250 mg / L at 60°C	storage tank cylinder
pH < 6.0 or > 9.5	storage tank cylinder
Total Dissolved Solids (TDS) > 600 mg / L	storage tank cylinder
Saturation Index (SI) > 0.4 (if expansion control valve is not fitted) at 80°C	storage tank cylinder temperature pressure relief valve
Saturation Index (SI) > 0.8 at 80°C	storage tank cylinder
Saturation Index (SI) < -1.0 at 80°C	storage tank cylinder

SAVE A SERVICE CALL

Check the items below before making a service call. You will be charged for attending to any condition or fault that is not related to manufacture or failure of a part.

NOT ENOUGH HOT WATER (OR NO HOT WATER)

- **Are you using more hot water than you think?**
Are outlets (especially the showers) using more hot water than you think? Very often it is not realised the amount of hot water used, particularly when showering. Carefully review the hot water usage. Have your plumber fit a flow control valve to each shower outlet to reduce water usage.
- **Temperature pressure relief valve running**
Is the relief valve discharging too much water? Refer to "Temperature Pressure Relief Valve Running" on page 14.
- **Thermostat setting**
Ensure the thermostat setting of the primary heating source is appropriate. You may choose to have your electrician adjust the thermostats upwards to gain additional hot water capacity.

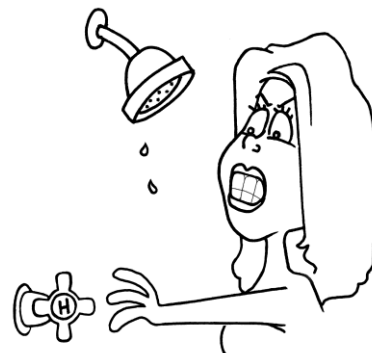

⚠ Warning: Hotter water increases the risk of scald injury.

- **Storage tank size**
Do you have the correct size water heater or sufficient storage for your requirements? The sizing guide in the Rheem sales literature and on the Rheem website (www.rheem.com.au) suggests average sizes that may be needed.

TEMPERATURE PRESSURE RELIEF VALVE RUNNING

- **Normal Operation**
It is normal and desirable that this valve allows a small quantity of water to escape during the heating cycle. However, if the discharge is deemed excessive (more than 2% of hot water used), there may be another problem.
 - **Continuous dribble**
Try gently raising the easing lever on the relief valve for a few seconds (refer to "Temperature Pressure Relief Valve" on page 10). This may dislodge a small particle of foreign matter and clear the fault. Release the lever gently.
 - **Steady flows for long period (often at night)**
This may indicate the mains water pressure sometimes rises above the designed pressure of the storage tank. Ask your installing plumber to fit a pressure limiting valve.
- ⚠ Warning:** Never replace the relief valve with one of a higher pressure rating.
- **Heavy flows of hot water until storage tank is cold - then stops until water reheats**
The primary heating source **must** be shut down and the energy source isolated. Phone Rheem Service or their nearest Accredited Service Agent to arrange for inspection.

EXPANSION CONTROL VALVE RUNNING

If an expansion control valve is fitted in the cold water line to the storage tank (refer to page 20) it may discharge a quantity of water instead of the temperature pressure relief valve on the storage tank. The benefit is that energy is conserved as the discharged water is cooler.

IF YOU HAVE CHECKED ALL THE FOREGOING AND STILL BELIEVE YOU NEED ASSISTANCE, PHONE RHEEM SERVICE OR THEIR NEAREST ACCREDITED SERVICE AGENT

INSTALLATION

THIS STORAGE TANK IS NOT SUITABLE FOR POOL HEATING

INSTALLATION STANDARDS

The storage tank must be installed:

- by a qualified person, and
- in accordance with the installation instructions, and
- in compliance with Standard AS/NZS 3500.4 and all local codes and regulatory authority requirements.

In New Zealand the installation must also conform to the New Zealand Building Code.

All packaging materials must be removed from the storage tank prior to its installation.

STORAGE TANK APPLICATION

This storage tank is designed for the purpose of storing heated potable water. Its use in an application other than this may shorten its life.

If this storage tank is to be used where an uninterrupted hot water supply is necessary for the application or business, then there should be redundancy within the hot water system design. This should ensure the continuity of hot water supply in the event that this storage tank was to become inoperable for any reason. We recommend you provide advice to the system owner about their needs and building backup redundancy into the hot water supply system.

STORAGE TANK LOCATION

This storage tank is suitable for either outdoor or indoor installation,

Whether located outdoor or indoor, the storage tank should be installed either close to the most frequently used outlets or with a circulated flow and return system, and its position chosen with safety and service in mind.

Clearance must be allowed for servicing of the storage tank. The storage tank must be accessible without the use of a ladder or scaffold. Make sure the temperature pressure relief valve lever is accessible and the thermostat (Tankstat) if fitted can be removed for service.

You must be able to read the information on the rating plate. Remember you may have to take the entire storage tank out later for servicing.

The storage tank is to be installed at ground or floor level and must stand vertically upright on a stable base as acceptable to local authorities and AS/NZS3500.4.

Note: The storage tank should not be placed in direct contact with a concrete surface that is less than two months old and not fully cured as this may attack the support legs. A moisture barrier should be used between the two surfaces in this instance

Lifting of Storage Tank

Each storage tank is supplied with suitable lifting lugs located at the top of the cylinder. Refer to storage tank technical data on page 19 and the rating plate for tank weight. Employ safe lifting techniques when locating the tank during installation, following instructions on page 35.

Remember all local authorities have regulations about putting storage tanks into roof spaces.

Refer to the instructions on pages 24 to 31 for storage tank installation options.

SAFE TRAY

Where damage to property can occur in the event of the storage tank leaking, the storage tank must be installed in a safe tray or the area suitably bunded. Construction, installation and draining of a safe tray must comply with AS/NZS 3500.4 and all local codes and regulatory authority requirements. AS/NZS 3500.4 also has particular requirements when a safe tray must be installed.

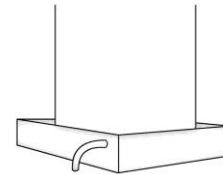

MAINS WATER SUPPLY

Where the mains water supply pressure exceeds that shown in the table below, an approved pressure limiting valve is required and should be fitted as shown in the installation diagram (refer to installation diagram on page 20).

Tank Nominal Capacity	933 L
Relief valve setting	850kPa
Expansion control valve setting*	700kPa
Max. mains supply pressure	
Without expansion control valve	680kPa
With expansion control valve	550kPa

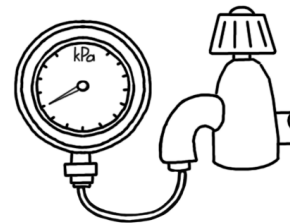

* Expansion control valve not supplied with storage tank

Where booster pump sets are used, damping must be incorporated to prevent cyclic water hammer acting on the cylinder. **Any resultant faults to the cylinder due to water hammer will not be covered by the Rheem warranty.**

TANK WATER SUPPLY

If the storage tank is supplied with water from a tank supply and a pressure pump system is not installed, then the bottom of the supply tank must be at least 1 m above the highest point of the hot water plumbing system, including the storage tank. Greater minimum pressures may apply depending on the method of heating being employed. Care must be taken to avoid air locks. The cold water line to the storage tank should be adequately sized and fitted with a full flow gate valve or ball valve. Consideration must be given to any minimum water supply pressure requirements of storage tank(s) which are part of the hot water plumbing system.

Hot Water Delivery

This storage tank can deliver water at temperatures which can cause scalding.

It is necessary and we recommend that a temperature limiting device be fitted between the storage tank and the hot water outlets in any ablution and public areas such as bathrooms, ensuites or public amenities to reduce the risk of scalding. The installing plumber may have a legal obligation to ensure the installation of this storage tank meets the delivery water temperature requirements of AS/NZS 3500.4 so that scalding water temperatures are not delivered to a bathroom, ensuite, or other ablution or public area.

Where a temperature limiting device is installed adjacent to the storage tank, the cold water line to the temperature limiting device can be branched off the cold water line either before or after the isolation valve and pressure limiting valve to the solar storage tank, but it **MUST BE** before the non return valve. If an expansion control valve is required, it must always be installed after the non return valve and be the last valve prior to the solar storage tank.

⚠ Warning: A non return valve **MUST BE** installed on the cold water line to the **solar** storage tank **AFTER** the cold water branch to a temperature limiting device.

If a combination isolation valve and non return valve (duo or trio valve) is installed on the cold water line to the storage tank and the cold water line to the temperature limiting device branches off after this valve, then a second non return valve must be installed between the cold water branch and the solar storage tank.

If a pressure limiting valve is installed on the cold water line to the storage tank and the cold water line to a temperature limiting device branches off before this valve or from another cold water line in the premises, then a pressure limiting valve of an equal pressure setting may be required prior to the temperature limiting device.

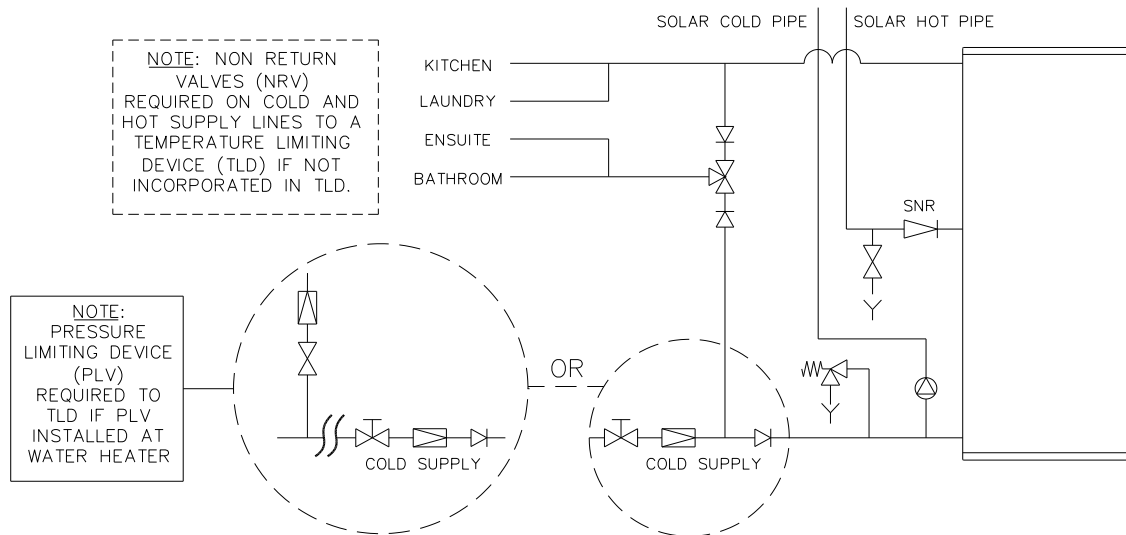

Two Temperature Zones Using a Temperature Limiting Device

CIRCULATED HOT WATER FLOW AND RETURN SYSTEM

If a storage tank is used with a primary water heating source and is to be installed as part of a circulated hot water flow and return system, the primary heating source must be able to provide a hot water outlet temperature of at least 60°C. **Note:** The thermostat must always be set to at least 60°C. Refer to the diagram on page 18.

If a storage tank is used as part of a solar water heater, it should not be installed as part of a circulated hot water flow and return system in a building. The benefits of solar gain will be significantly reduced and energy gained from the sun lost through the pipe work. If a circulated flow and return system is required, it is necessary to connect the return line after the solar preheat system and prior to the in-series booster water heater supplied from the solar preheat system. The in-series booster water heater must be able to provide a hot water outlet temperature of at least 60°C. **Note:** The thermostat must always be set to at least 60°C.

Temperature Limiting Device

A temperature limiting device cannot be installed in circulated hot water flow and return pipe work unless it is specifically designed to do so, such as the Rheem Guardian warm water system.

The tempered water from a temperature limiting device cannot be circulated. Where a circulated hot water flow and return system is required in a building, a temperature limiting device can only be installed on a dead leg, branching off the circulated hot water flow and return pipe.

If circulated tempered water were to be returned back to the water heater or storage tank, depending on the location of the return line connection on the water supply line to the water heater or storage tank, then either:

- water will be supplied to the cold water inlet of the temperature limiting device at a temperature exceeding the maximum recommended water supply temperature, or
- when the hot taps are closed no water will be supplied to the cold water inlet of the temperature limiting device whilst hot water will continue to be supplied to the hot water inlet of the temperature limiting device.

These conditions may result in either water at a temperature exceeding the requirements of AS/NZS 3500.4 being delivered to the hot water outlets in the ablution areas, or the device closing completely and not delivering water at all, or the device failing. Under either condition, the operation and performance of the device cannot be guaranteed.

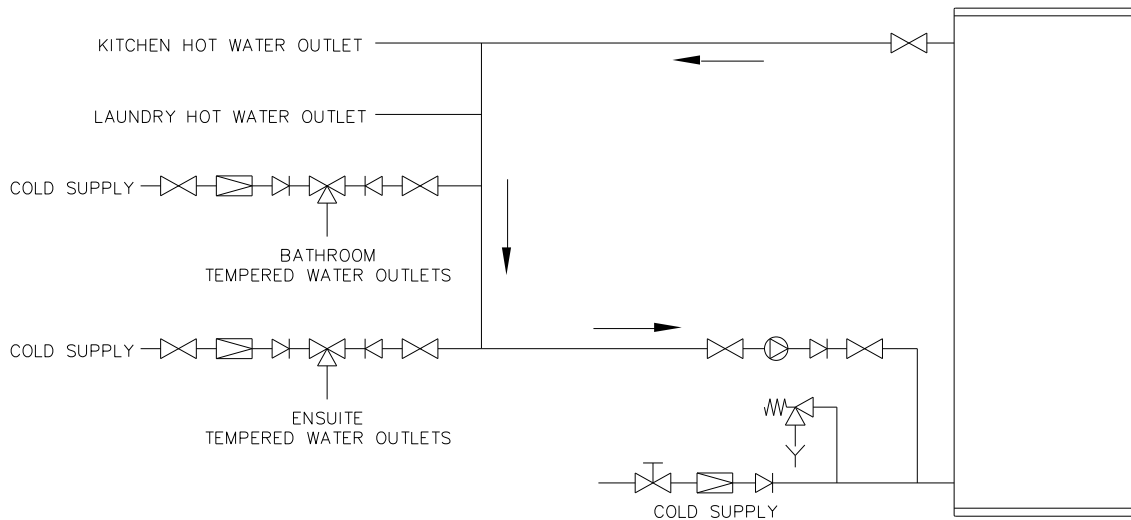

**Circulated Hot Water Flow and Return System
Storage Tank with Primary Water Heater**

REDUCING HEAT LOSSES

The cold water line to, primary flow and return lines and the hot water line from the storage tank must be insulated in accordance with the requirements of AS/NZS 3500.4. The insulation must be weatherproof and UV resistant if exposed.

Keep temperature settings down. Lower temperatures reduce heat losses and prolong cylinder life. Do not set the controlling thermostats on the primary heating plant above 70°C unless it is necessary.

SADDLING PIPE WORK

Pipe work must not be saddled to the tank.

Note: If the cylinder or insulation is damaged as a result of attaching pipe clips or saddles to the jacket, any resultant faults will not be covered by the Rheem warranty.

DIMENSIONS AND TECHNICAL DATA

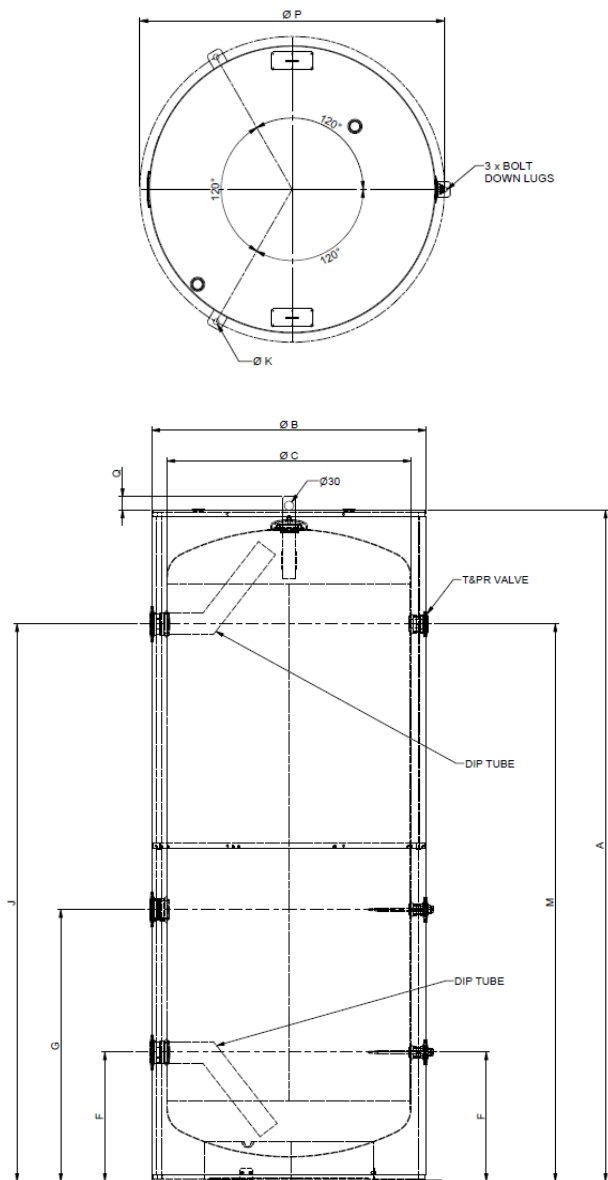

Model Designation			RJ1050N80	Notes
Storage Capacity		Litre	933	
Dimensions	A	mm	2170	
	B	mm	889	
	C	mm	790	
	F	mm	417	
	G	mm	879	
	J	mm	1803	
	K	mm	17	Tie-down feet bolt hole diameter
	M	mm	1803	
	P	mm	944	Tie-down feet centre line, or set-
	Q	mm	50	
Weight Empty		kg	121	
Inlet/Outlet Connections (BSPP)		in	Rp 2	
T&PR Valve Connection BSPP)		in	Rp 1	
Sensor Connection (thermowell supplied) (BSPP)			Rp 1/2 or Rp 3/4	

CONNECTIONS – PLUMBING

All plumbing work must be carried out by a qualified person and in accordance with the Standard AS/NZS 3500.4 and all local codes and regulatory authority requirements. In New Zealand the installation must also conform with the New Zealand Building Code.

CONNECTION SIZES

The storage tank is supplied with three water connections. The diagrams on pages 265 to 31 show some of the more common system configurations.

Disconnection unions and isolation valves must be installed on all piping connections to the storage tank. Unused fittings must be plugged (plugs not supplied).

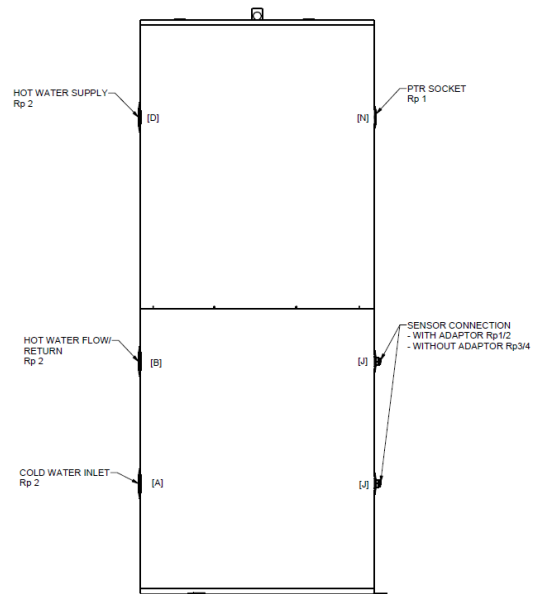

Fitting	Description
A, B, D	WATER CONNECTION FITTINGS BSP Rp 2

WATER INLET AND OUTLET

All pipe work must be cleared of foreign matter before connection and purged before attempting to operate the storage tank. All olive compression fittings must use brass or copper olives. Use thread sealing tape or approved thread sealant on all fittings.

An isolation valve and non-return valve must be installed on the cold water line to the storage tank. An acceptable arrangement is shown in the diagram and on pages 26, 28 or 30 for multiple installations. Refer also to "Hot Water Delivery" on page 16 and to "Mains Water Supply" on page 16.

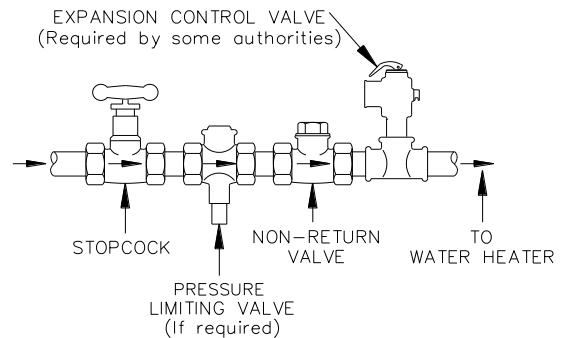

PIPE SIZES

The pipe sizing of hot water supply systems for commercial installations should be carried out by persons competent to do so, choosing the most suitable pipe size for each individual application. Reference to the technical specifications of the primary heating source, storage tank and local regulatory authority requirements must be made.

TEMPERATURE AND PRESSURE RELIEF VALVE

The storage tank is supplied with a 1" Temperature and Pressure Relief Valve. The valve is supplied in a box with the included installation kit.

The temperature pressure relief valve must be fitted before the storage tank is operated. Before fitting the relief valve, make sure the probe has not been bent. Seal the thread with an approved thread sealant such as Teflon tape - never hemp. Make sure the tape does not hang over the end of the thread.

Screw the temperature and pressure relief valve into the correct opening (refer to the tank diagram on page 20) leaving the valve drain pointing downwards.

Do not use a wrench on the valve body - use the spanner flats provided. A copper drain line must be fitted to the temperature pressure relief valve (refer to "Relief Valve Drain" on page 22).

The valve must be insulated with closed cell polymer insulation or similar (minimum thickness 9 mm) and the insulation installed so as not to impede the operation of the valve. The insulation must be weatherproof and UV resistant if exposed.

CONNECTIONS – PLUMBING

EXPANSION CONTROL VALVE

Local regulations may make it mandatory to install an expansion control valve (ECV) in the cold water line to the storage tank. In other areas, an ECV is required if the saturation index is greater than +0.4 (refer to “Water Supplies” on page 11).

The expansion control valve must always be installed after the non return valve and be the last valve installed prior to the storage tank (refer to diagram on page 20). A copper drain line must be fitted to the expansion control valve (refer to "Relief Valve Drain" on page 22).

The valve, if installed within 500 mm of the storage tank, must be insulated with closed cell polymer insulation or similar (minimum thickness 9 mm) and the insulation installed so as not to impede the operation of the valve. The insulation must be weatherproof and UV resistant if exposed.

RELIEF VALVE DRAIN

Copper drain lines, no smaller than the outlet size of the relevant temperature pressure relief valve/s and expansion control valve (if one is installed) must be fitted to carry the discharge clear of the storage tank. Connect the drain lines to the valve and/or tundish using disconnection unions. The drain line from the valve to the point of discharge should be as short as possible, have a continuous fall all the way from the storage tank to the discharge outlet and have no tap, valves or other restrictions in the pipe work. A drain line from a relief valve must comply with the requirements of AS/NZS 3500.4.

A drain line must be no longer than 9 metres with no more than three bends greater than 45° before discharging at an outlet or air break. The maximum length of 9 metres for a drain line is reduced by 1 metre for each additional bend required of greater than 45°, up to a maximum of three additional bends. Where the distance to the point of final discharge exceeds this length, the drain line can discharge into a tundish.

Subject to local regulatory authority approval, the drain lines from the temperature pressure relief valve and expansion control valve from an individual storage tank may be interconnected.

The outlet of a drain line must be in such a position that flow out of the pipe can be easily seen, but arranged so discharge will not cause injury, damage or nuisance. The termination point of a drain line must comply with the requirements of AS/NZS 3500.4. Drain lines must not discharge into a safe tray.

In locations where water pipes are prone to freezing, drain lines must be insulated, must not exceed 300 mm in length and are to discharge into a tundish through an air gap of between 75 mm and 150 mm.

If a drain line discharges into a tundish, the drain line from the tundish must be not less than DN32. The drain line from a tundish must meet the same requirements as for a drain line from a relief valve.

For multiple installations the drain lines from several storage tanks can discharge into a common tundish (refer to “Multiple Installations” on page 25).

⚠ Warning: As the function of the temperature pressure relief valve on this storage tank is to discharge high temperature water under certain conditions, it is strongly recommended the pipe work downstream of the relief valve be capable of carrying water exceeding 93°C. Failure to observe this precaution may result in damage to pipe work and property.

VENTED STORAGE APPLICATIONS

If the storage tank is to be used in an open vented application, the storage tank must be fitted with a permanently open vent to atmosphere. The vent must be suitably sized to ensure sufficient discharge capacity to prevent the pressure in the storage tank exceeding the rated working pressure under conditions of uncontrolled maximum input.



WARNING: Plumber – Be Aware

- The primary flow and return pipes between the storage tank(s) and the primary water heating source, including the solar hot and solar cold pipes between the solar storage tank(s) and the solar collectors, **MUST BE** of copper, or metallic. All compression fittings must use brass or copper olives.
- Plastic pipe **MUST NOT** be used, as it will not withstand the temperature of the water generated by the primary heating source under certain conditions. The primary heating source may generate extremely high water temperatures and high water pressure of 850 kPa. Plastic pipe cannot withstand these temperatures and pressures, and **MUST NOT** be used. Failure of plastic pipe can lead to the release of high temperature water and cause severe water damage and flooding.
- A non return valve **MUST BE** installed on the cold water line to the storage tank **AFTER** the cold water branch to a temperature limiting device.
- The full length of the primary flow and return pipes **MUST BE** insulated.

The insulation must:

- be of a type suitable for the application and capable of withstanding the temperature of the water generated by the primary water heating source

The specification of the chosen insulation material should be checked with the insulation manufacturer prior to installation as different materials may vary in temperature tolerance.

- be at least 13 mm thick, however thicker insulation may be required to comply with the requirements of AS/NZS 3500.4
- be weatherproof and UV resistant if exposed
- be fitted up to and cover the connections on both the storage tank(s) and the primary heating source.

The insulation will reduce pipe heat losses and also assist in avoiding accidental contact with the pipe work as high temperature water can flow from the primary heating source and the storage tank(s).

- In addition, the insulation on the solar hot and solar cold pipes must also:
 - extend through any penetrations in the eaves, ceiling and roof
 - cover valves and fittings in the solar hot and solar cold pipe work

Note: Failure to observe these requirements also increases the risk of freeze damage.

The insulation is essential to assist in providing freeze protection and will offer corrosion protection to a metal roof against water runoff over the copper pipe.

Uninsulated pipe work, including concealed in cavities and roof spaces or where it may be in contact with a metal roof, may lead to freeze damage. The system has NO WARRANTY for freeze damage if the solar hot and solar cold pipes are not insulated in accordance with the installation instructions.

MULTIPLE INSTALLATIONS

A multiple installation of storage tanks on a single manifold or multiple manifolds is possible, using the Equa-Flow® manifold system, where large volumes of hot water is required. The Equa-Flow principle will function with storage tanks in line, around a corner or in rows back to back (refer to the diagrams on page 245).

The cold water and hot water manifolds must be designed to balance the flow from each storage tank. To achieve this, there are basic installation requirements and principles which must be followed:

1. The maximum number of storage tanks in a bank should be 10, however several banks of storage tanks can be installed.
2. The hot water line from the manifold must leave from the opposite end to which the cold water line enters the manifold.
3. The storage tanks must be of the same model.
4. The cold water line, cold and hot headers and hot water line must be sized to meet the requirements of both AS/NZS 3500.4 and the application.
5. The primary flow and return lines must be sized to meet the requirements of AS/NZS 3500.4 and suit the primary heating source. Refer to the literature supplied with the primary heating source.
6. A non return valve, isolation valve and if required a pressure limiting valve and expansion control valve, must be installed on the cold water line to the system.
7. A full flow gate valve or ball valve (not a stop tap, as used on a single storage tank installation) must be installed on the cold water branch, primary flow /return branch and hot water branch of each storage tank.
8. Non return valves or pressure limiting valves must not be installed on the branch lines to the storage tanks.
9. All fittings, valves and branch lines must be matched sets all the way along the manifold.
10. Sufficient space must be left to enable access, servicing or removal of any storage tank.
11. The temperature pressure relief valve drain line from each storage tank can terminate at a common tundish (funnel) with a visible air break at each drain discharge point (refer to the 5 and to "Relief Drain Line" on page 22).

Refer to the diagrams on pages 245 to 31 for installation and plant layout details.

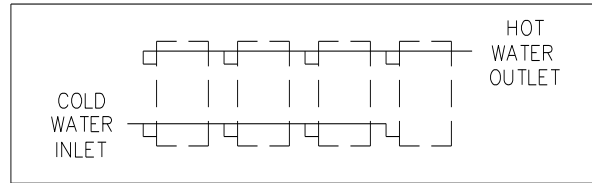
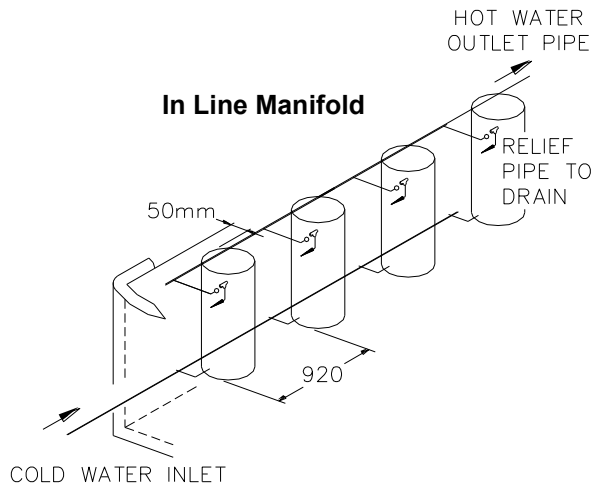

Single Bank of Storage Tanks

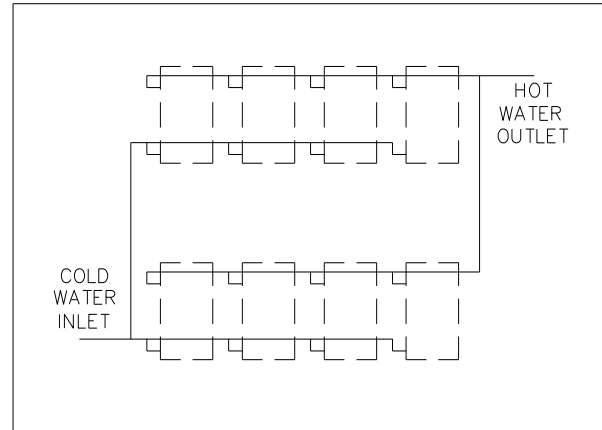
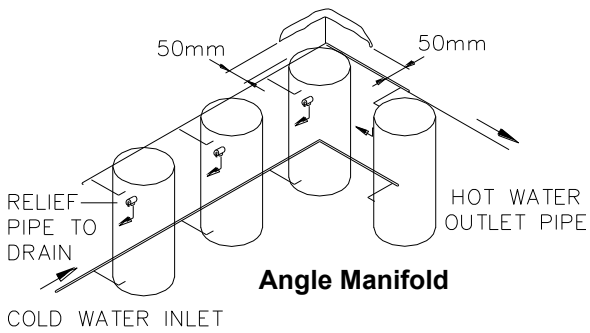

Multiple Banks of Storage Tanks

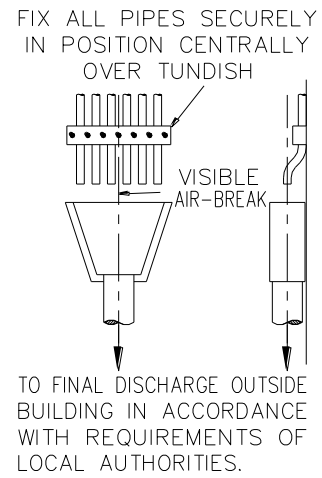
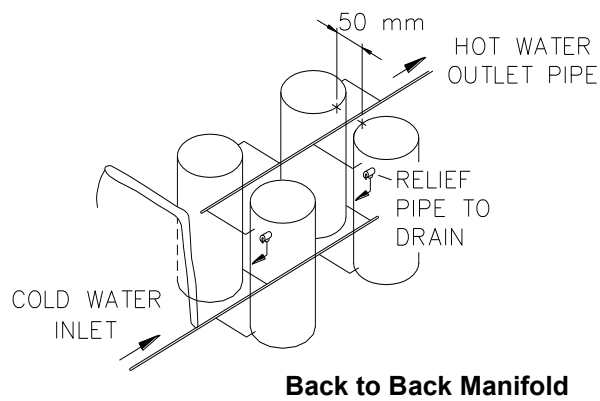

TPR Valve Drain Line Common Discharge Point

MANIFOLD ARRANGEMENT – DIRECT SOLAR INSTALLATION

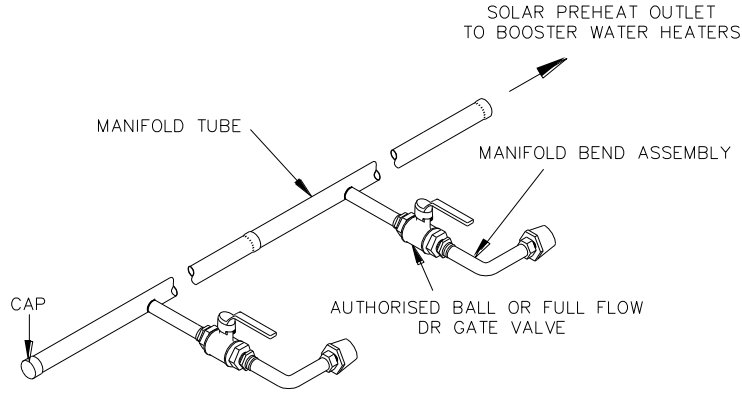

Hot Manifold Assembly

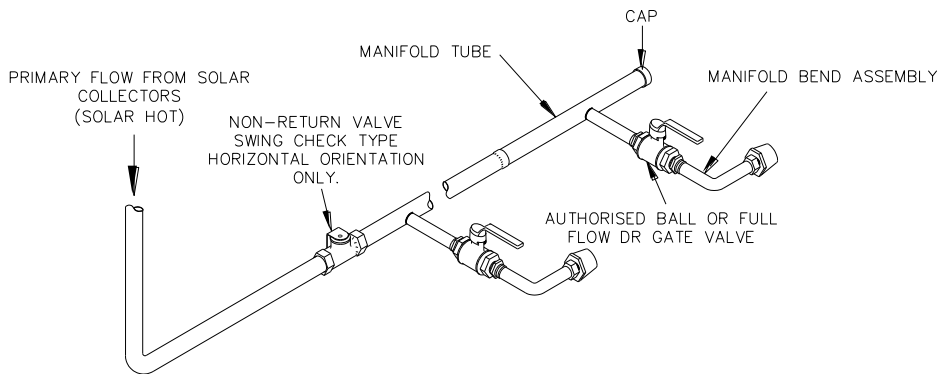

Solar Primary Flow Manifold Assembly

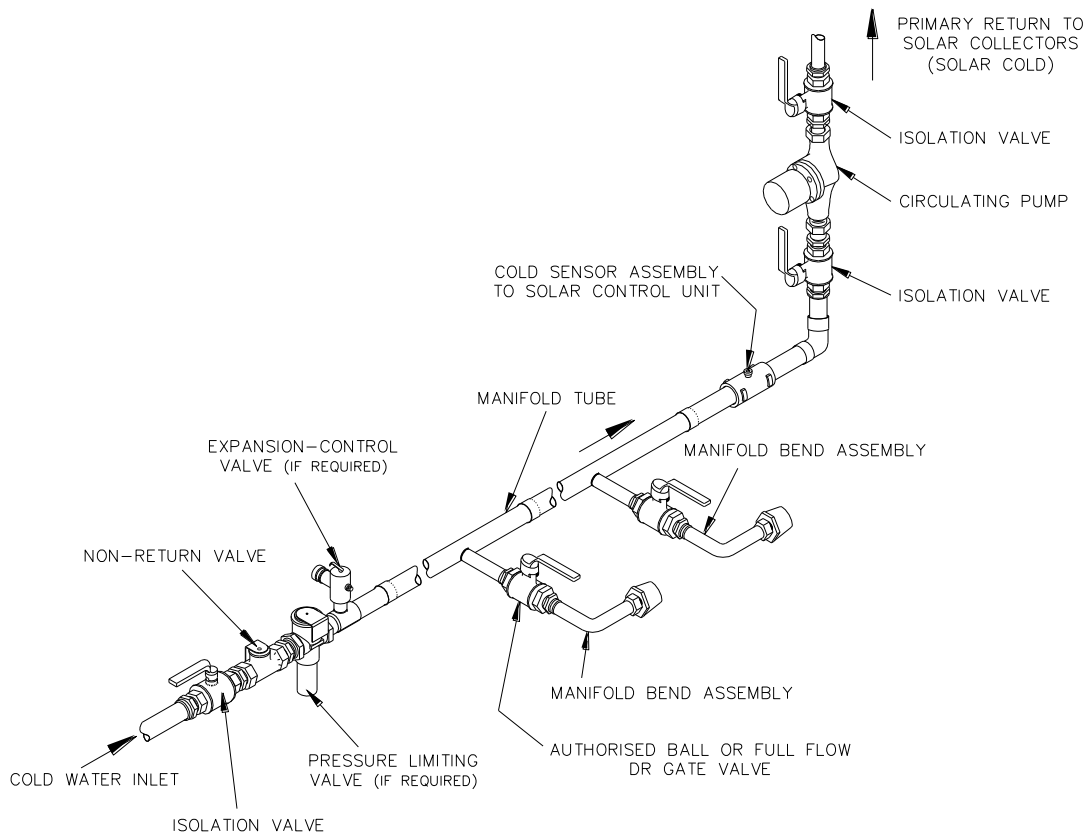

Cold Manifold Assembly

TYPICAL INSTALLATION – DIRECT SOLAR STORAGE TANKS

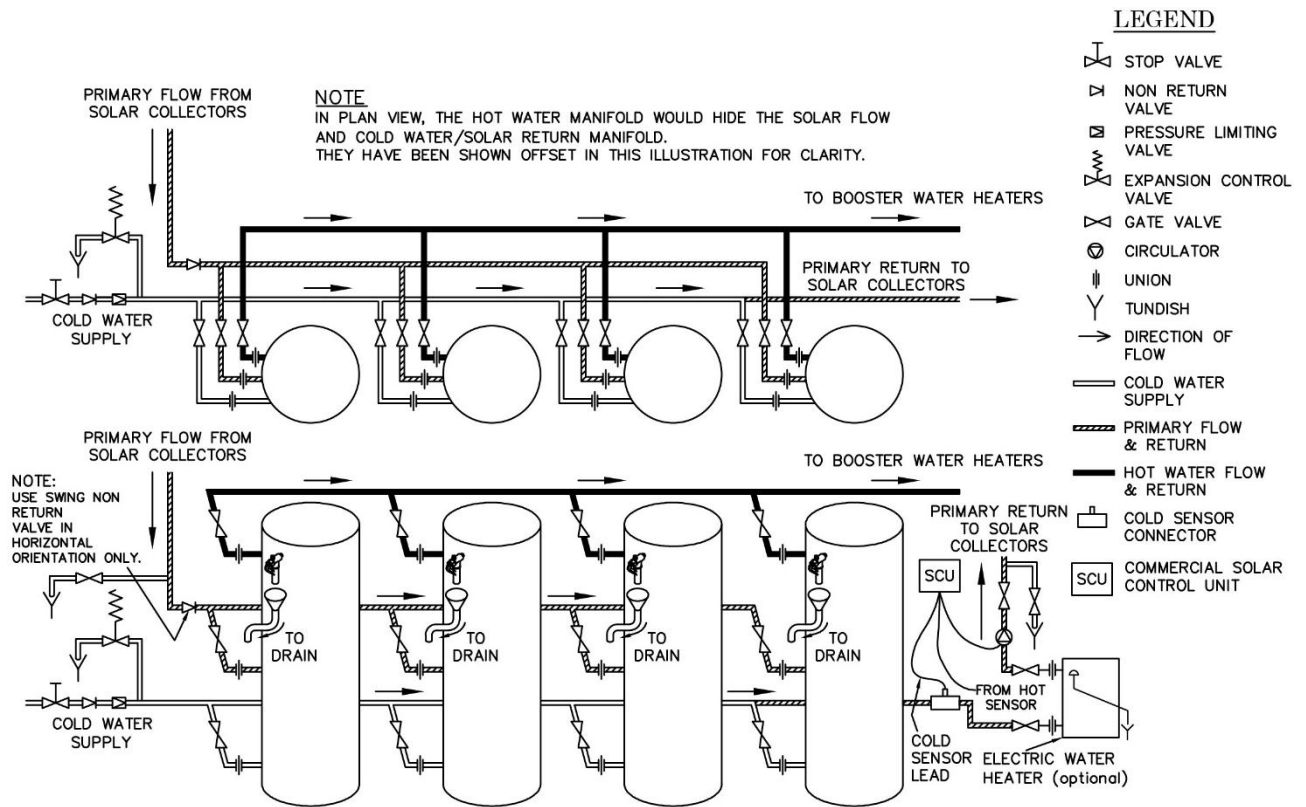

INSTALLATION DIMENSIONS – COMMERCIAL STORAGE TANKS

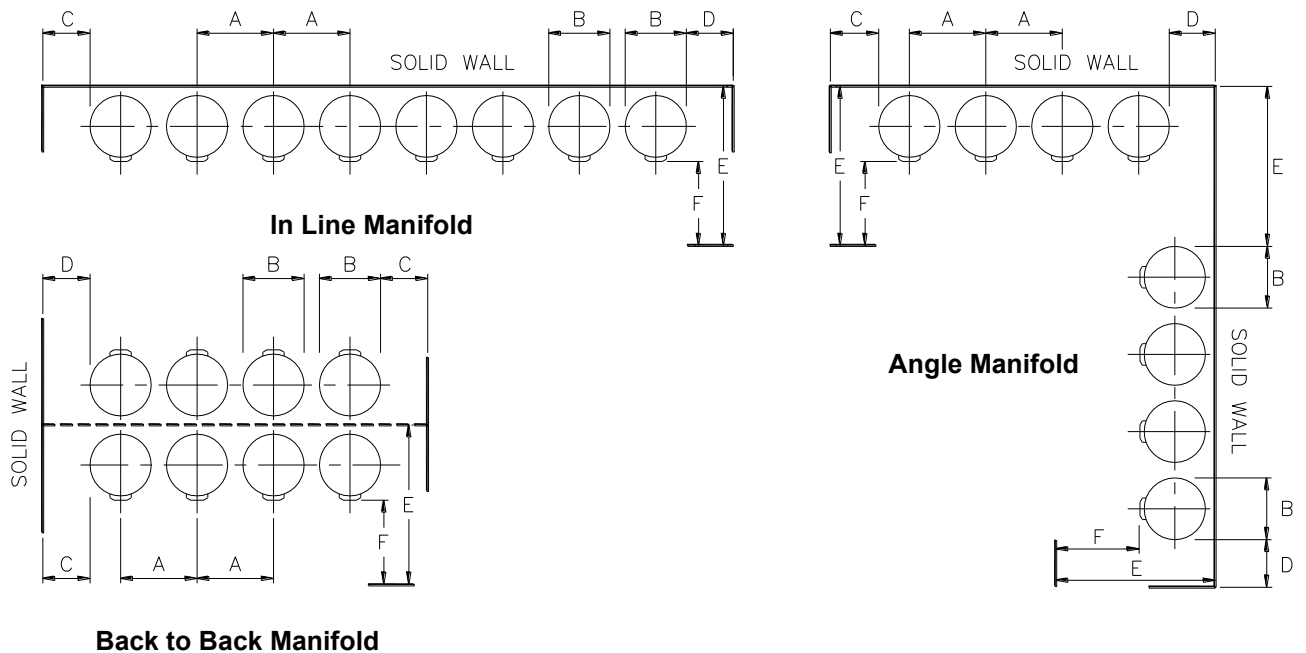

Notes :

- Minimum recommended space between wall and back of storage tank is 100 mm.
- (E) Minimum distance for storage tank removal.
- (F) A minimum of 900 mm should be left in front of the storage tank for access & servicing

Installation Layout Minimum Dimensions						
Model	A	B	C	D	E	F
RJ1050	1240	889	300	100	2060	900

MANIFOLD ARRANGEMENT – HEAT PUMP STORAGE TANK INSTALLATION

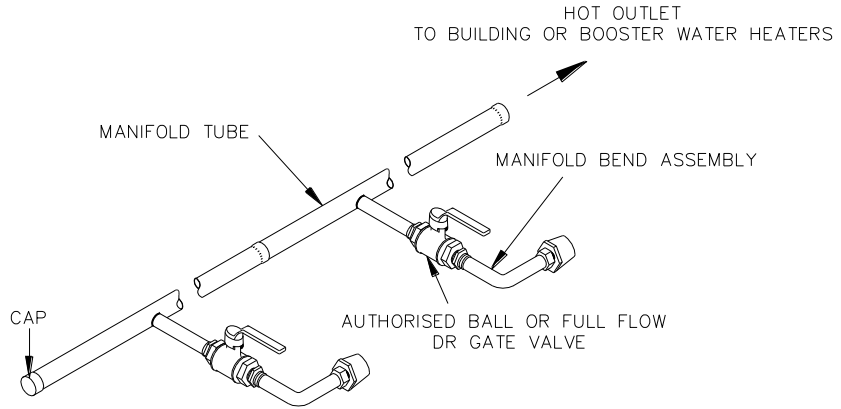

Hot Manifold Assembly

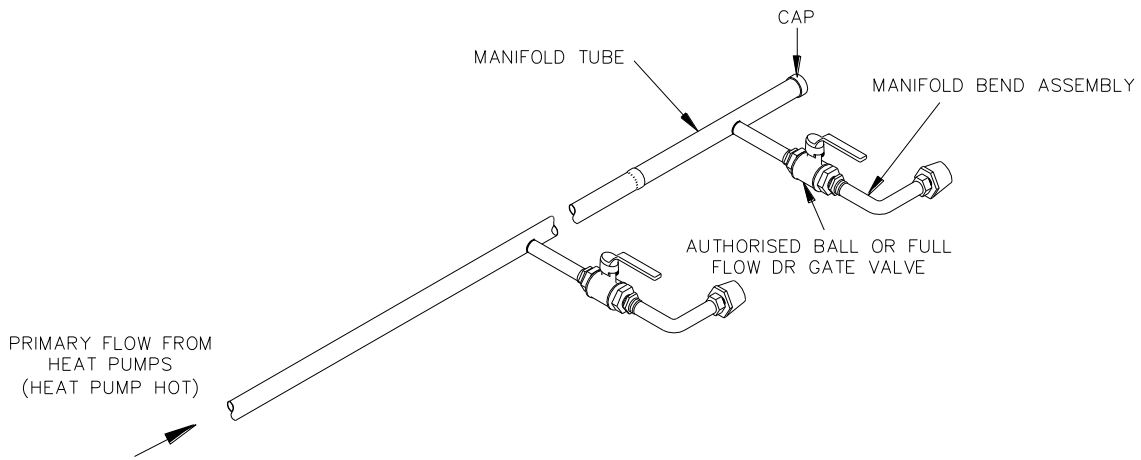

Heat Pump Primary Flow Manifold Assembly

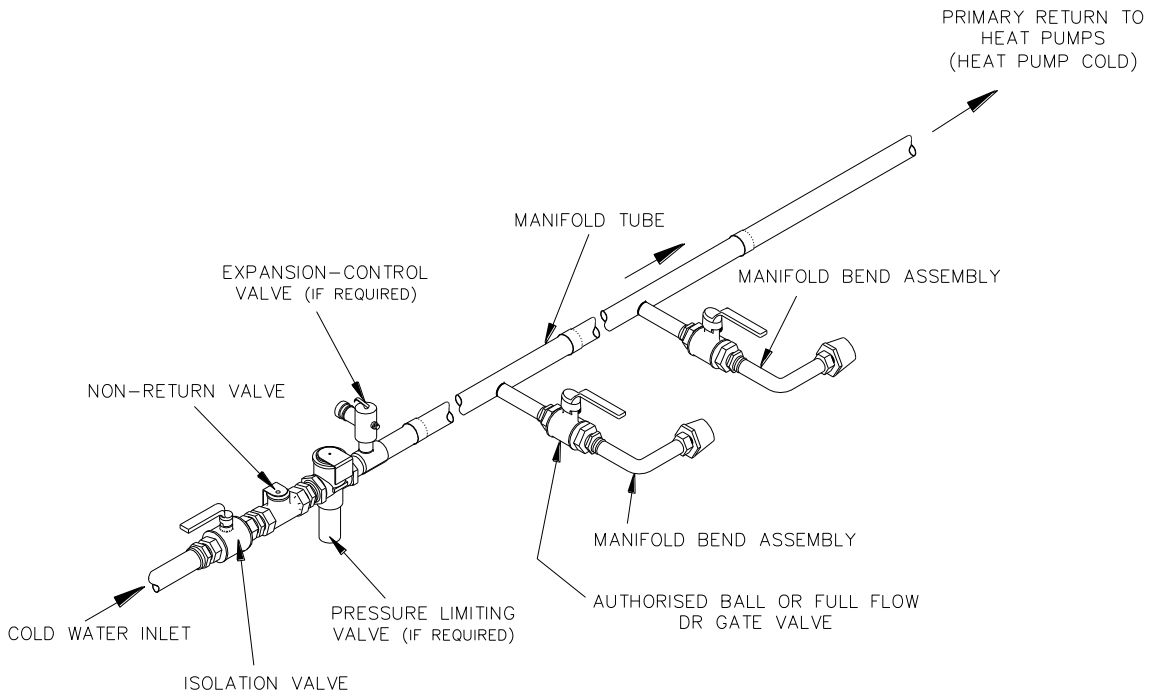

Cold Manifold Assembly

TYPICAL INSTALLATION – HEAT PUMP WATER HEATERS

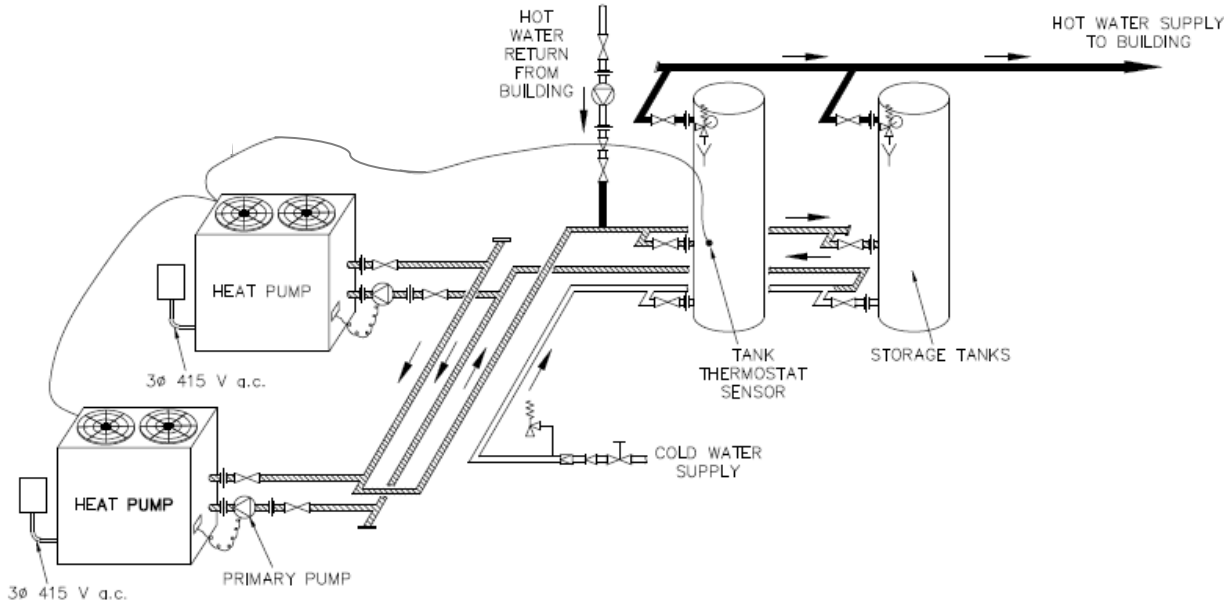

LEGEND

- | | | | | | | | |
|---|-------------------------|---|-------------------------|---|-------------------|---|-------------------------|
| ⊥ | STOP VALVE | ⌞ | EXPANSION CONTROL VALVE | ⊥ | UNION | ▭ | COLD WATER SUPPLY |
| ⊘ | NON RETURN VALVE | ⌞ | GATE OR BALL VALVE | ⌞ | TUNDISH | ▨ | PRIMARY FLOW & RETURN |
| ⊞ | PRESSURE LIMITING VALVE | ⊙ | CIRCULATOR | → | DIRECTION OF FLOW | ▬ | HOT WATER FLOW & RETURN |

TYPICAL INSTALLATION – STORAGE TANKS FOR HEAT PUMPS

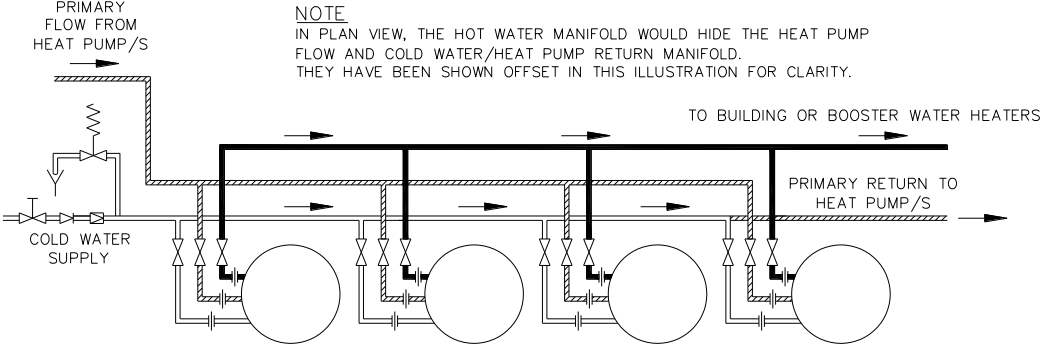

LEGEND

- | | | | | | | | |
|---|-------------------|---|-------------------------|---|-------------------------|---|----------------|
| ⊥ | STOP VALVE | ⊞ | PRESSURE LIMITING VALVE | ⊞ | EXPANSION CONTROL VALVE | ⊙ | CIRCULATOR |
| ⊘ | NON RETURN VALVE | ⌞ | GATE VALVE | ⊥ | UNION | ⌞ | TUNDISH |
| → | DIRECTION OF FLOW | ▭ | COLD WATER SUPPLY | ▨ | PRIMARY FLOW & RETURN | ▬ | HOT WATER FLOW |

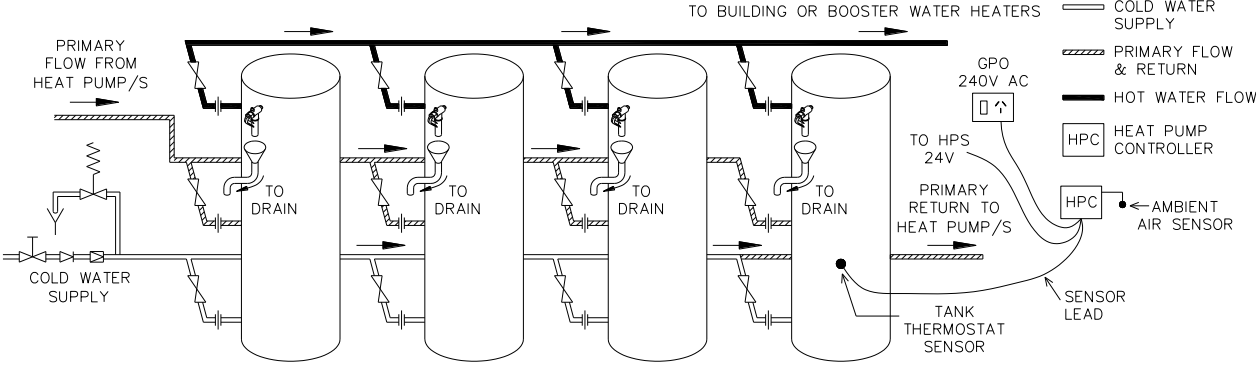

MANIFOLD ARRANGEMENT – RAYPAK INSTALLATION

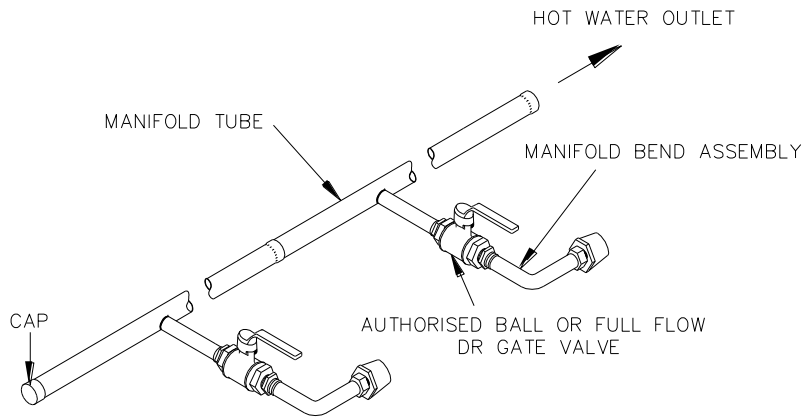

Hot Manifold Assembly

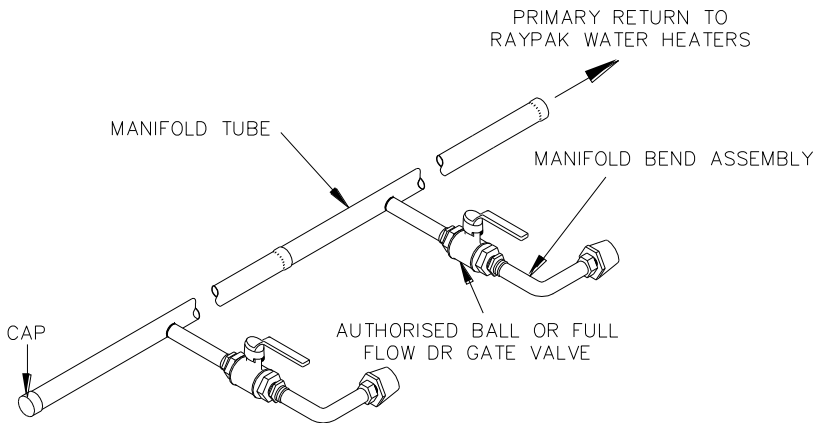

Heating Manifold Assembly

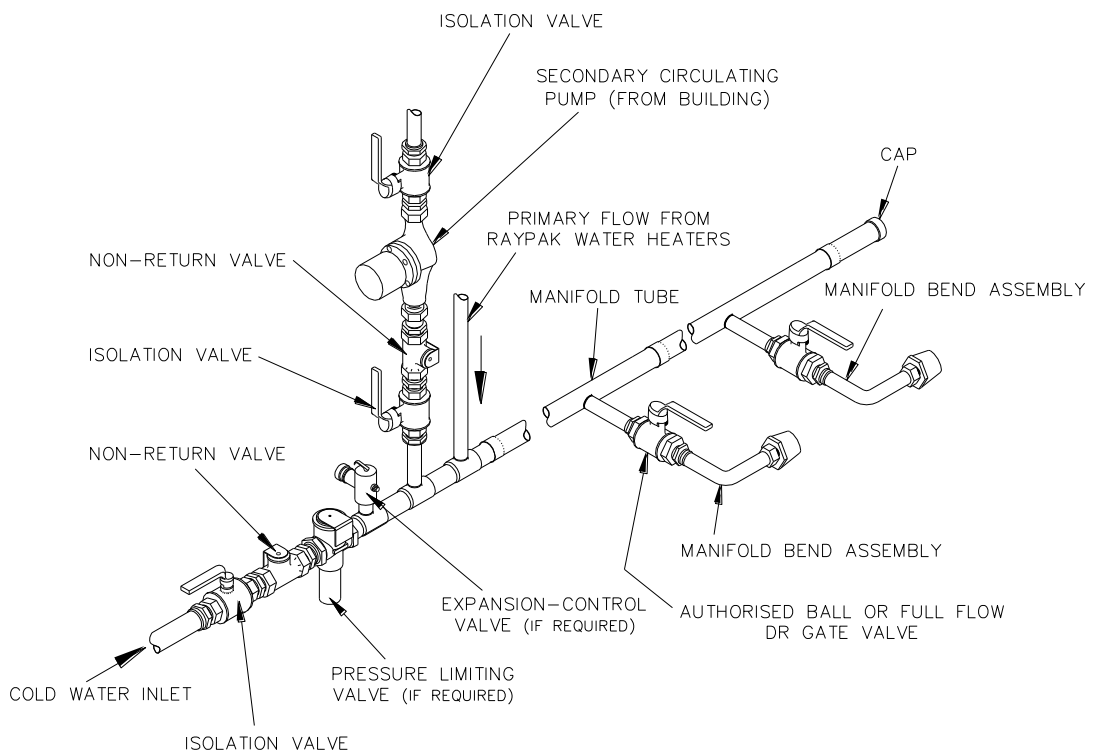

Cold Manifold Assembly

TYPICAL INSTALLATION – ATMOSPHERIC AND MVB WATER HEATERS

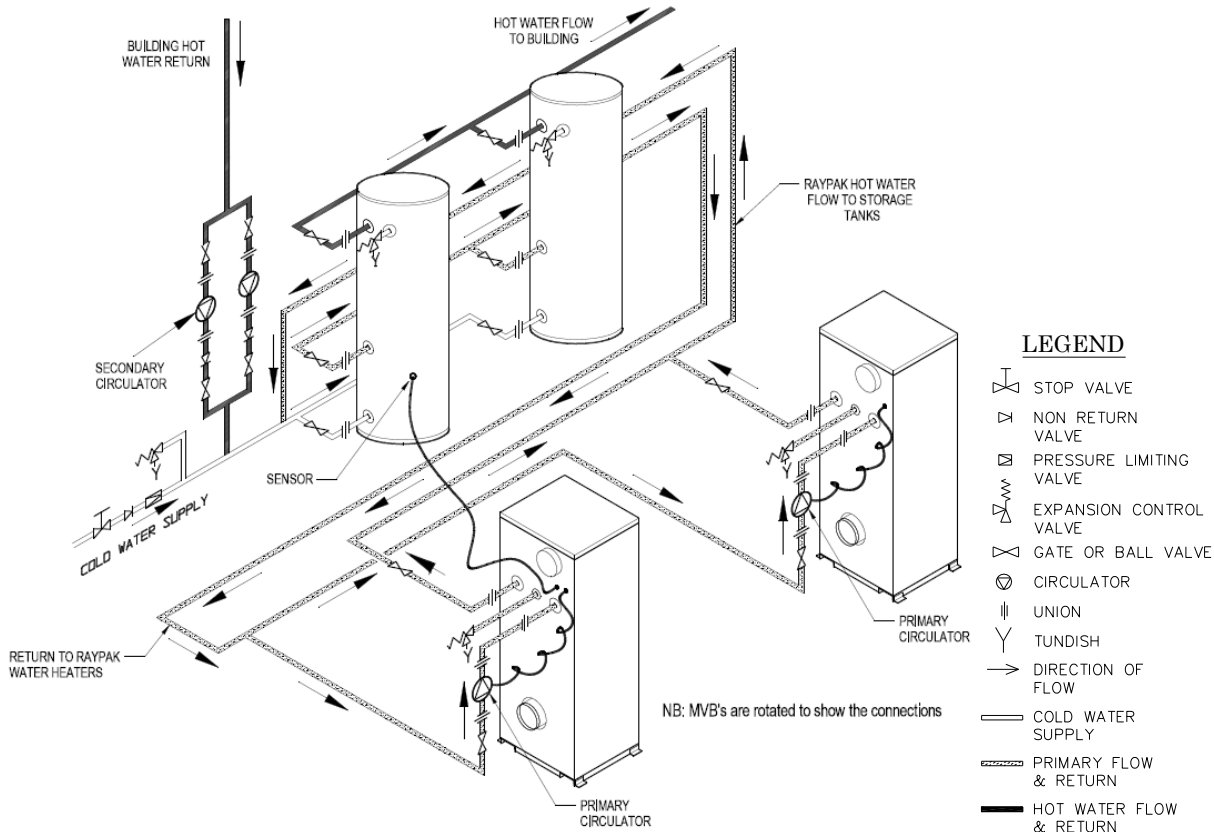

TYPICAL INSTALLATION – STORAGE TANKS FOR RAYPAK

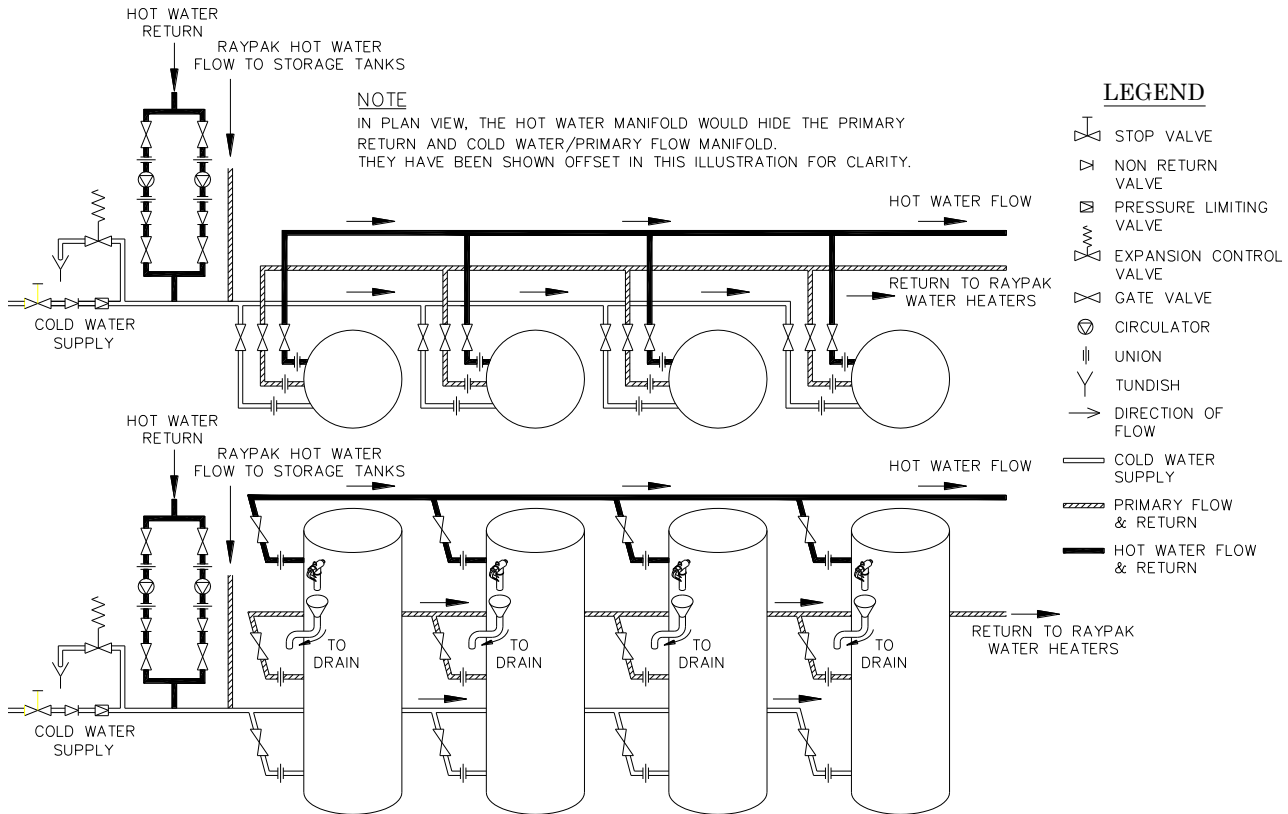

CONNECTIONS – ELECTRICAL

The power supply to the primary heating source and circulating pumps must not be switched on until the storage tank is filled with water and a satisfactory megger reading is obtained.

No electrical connections are to be made on the storage tank, except if a remote thermostat is fitted. All electrical work and permanent wiring must be carried out by a qualified person and in accordance with the Wiring Rules AS/NZS 3000 and all local codes and regulatory authority requirements.

REMOTE THERMOSTAT

The storage tank is fitted with 2 x Rp 3/4 fittings and 2 x Rp 3/4 - Rp 1/2 adaptors. These fittings are used to monitor system temperature. 2 x Rp1/2 thermostat wells are supplied and fitted with the storage tank.

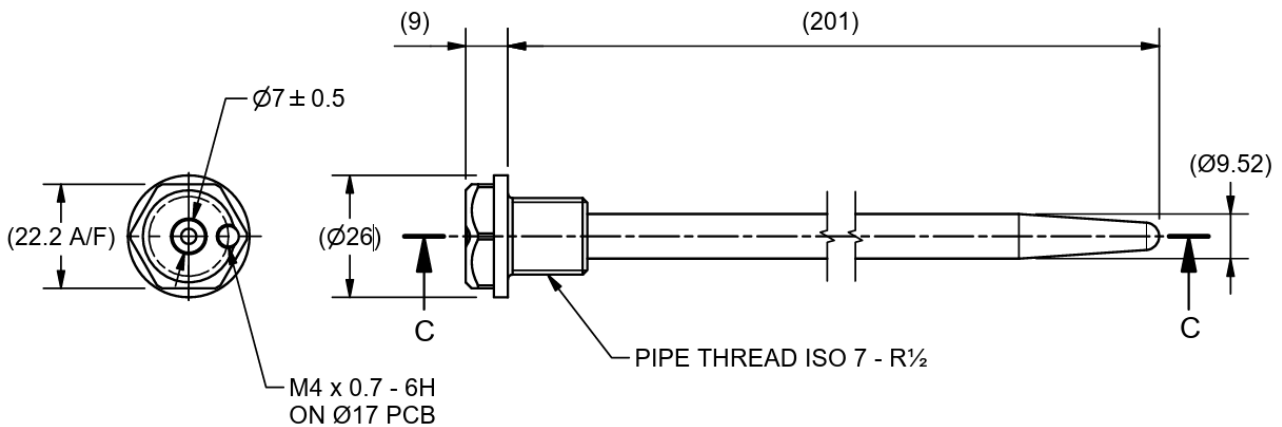

Thermowell Dimensions

COMMISSIONING

TO FILL AND TURN ON THE STORAGE TANK

The power supply to the primary heating source and circulating pumps must not be switched on until the storage tank is filled with water and a satisfactory megger reading is obtained.

- Open all of the hot water tap(s) in the building (don't forget the shower(s)) and supply cock(s) and valve(s) in the system.
- Open the isolation valves fully on the cold, flow / return and hot water branches to the storage tank(s) installed in a bank.
- Open the cold water isolation valve on the cold water line to the storage tank(s).
Air will be forced out of the taps.
- Close each tap as water flows freely from it.
- Check the pipe work for leaks.
- Switch on the electrical supply at the isolating switch to the circulating pump(s) and turn on the primary water heating plant.
- When the system has reached its working temperature, check the pipe work again for leaks.

Explain to a responsible officer the functions and operation of the water heating system. Upon completion of the installation and commissioning of the water heating system, leave this guide with a responsible officer.

TO TURN OFF THE STORAGE TANK

If it is necessary to turn off the storage tank on completion of the installation, such as on a building site or where the premises is vacant, then:

- Shut down the primary water heating plant and switch off the electrical supply at the isolating switch to the circulating pump(s).
- Close the cold water isolation valve on the cold water line to the storage tank(s) to shut down the entire system, or;

Close the isolation valves on the cold, flow / return and hot water branches to shut down an individual storage tank in a bank

DRAINING THE STORAGE TANK

⚠ Warning: Exercise care, as water discharged from the storage tank may be of a very high temperature.

To drain the storage tank:

- Turn off the storage tank (refer to “To Turn Off The Storage Tank” on page 33).
- Close all hot water taps.
- Operate the relief valve release lever - do not let the lever snap back or you will damage the valve seat.
Operating the lever will release the pressure in the storage tank.
- Undo the union at the cold water inlet to the storage tank and attach a hose to the storage tank side of the union.

Let the other end of the hose go to a drain.

- Operate the relief valve again.

This will let air into the storage tank and allow the water to drain through the hose.

LIFTING THE TANK

The tank has two lifting points (lugs) which allow it to be lifted into its installation position. The following must be followed when lifting the tank:

- The tank must be lifted from the vertical orientation only.
- Both lifting points must be used.
- The lifting lugs will support the weight of the tank (when empty) and the supplied crate. No additional items are to be added when the tank is being lifted.
- Tank must be completely empty when lifted.
- A spreader bar/beam must be used when lifting the tank. Refer to the diagram below for bar details.
- Only qualified personnel are to conduct the lifting of the tank.
- The minimum size of the shackles must be ≥ 22 mm.

Contact Rheem for further information regarding lifting of tank.

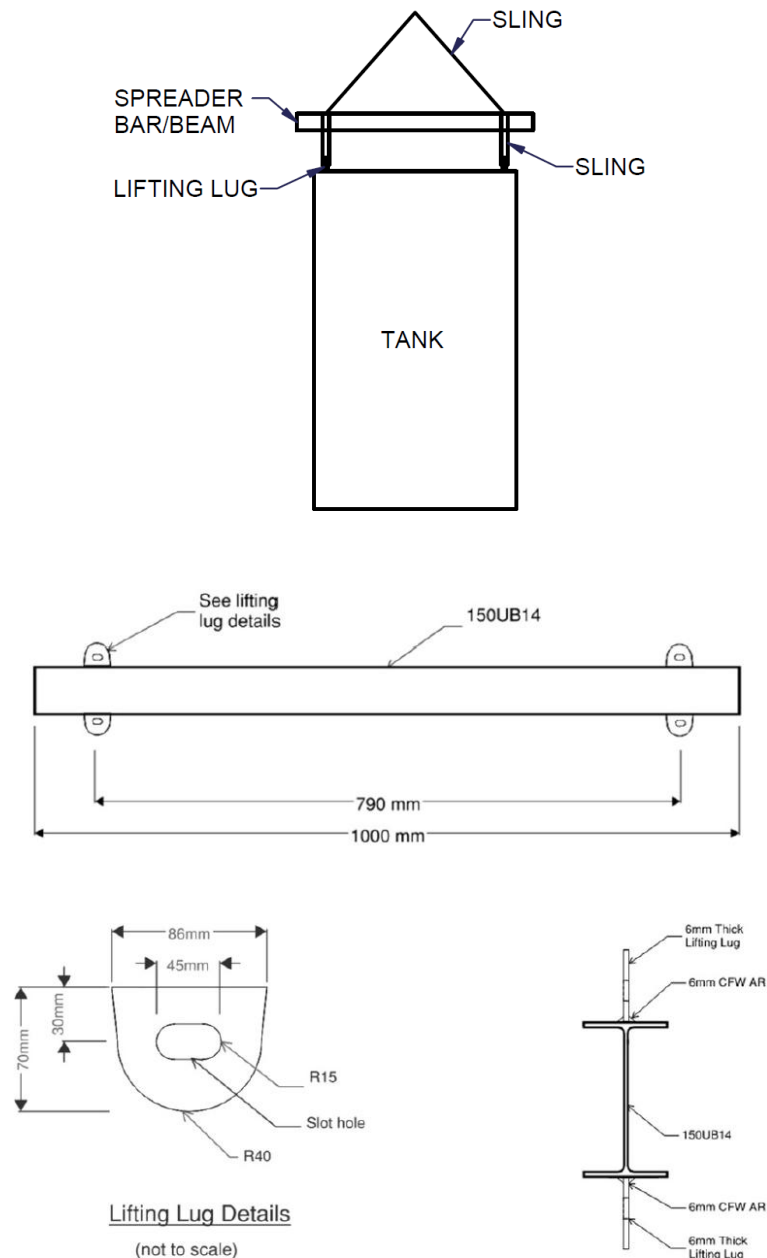

RHEEM AUSTRALIA PTY LTD, A.B.N. 21 098 23 511
www.rheem.com.au
www.rheem.co.nz

FOR SERVICE TELEPHONE
131 031 AUSTRALIA
0800 657 335 NEW ZEALAND

February 2026
AQ0901165-01