

# *Owner's Guide and Installation Instructions*

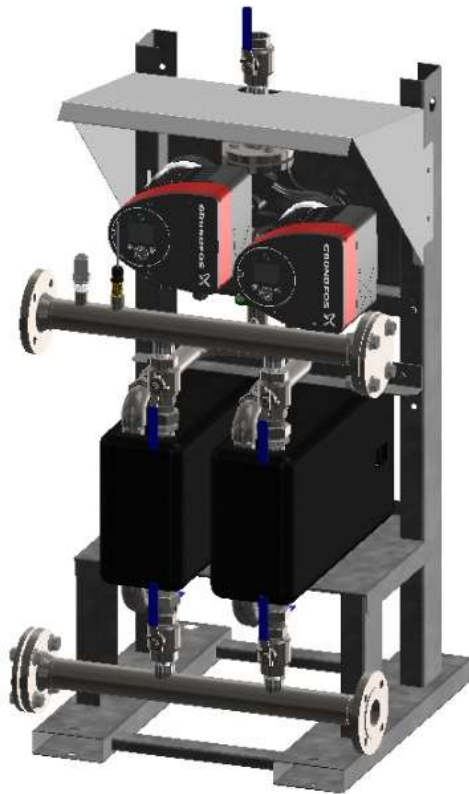

## *Rheem Crossflow™ Instantaneous Heat Exchange Delivery System*



*This water heater must be installed and serviced by a qualified person.  
Please leave this guide with a responsible officer.*

---

# CONTENTS

---

CONTENTS .....	2
DESCRIPTION .....	4
SYSTEM INSTALLATION .....	9
CROSSFLOW PRIMARY CONNECTIONS .....	9
POTABLE WATER CONNECTIONS TO CROSSFLOW SYSTEM .....	11
COLD WATER SUPPLY.....	11
HOT WATER SUPPLY .....	11
MULTIPLE INSTALLATIONS .....	11
ELECTRICAL CONNECTIONS .....	12
WATER SUPPLIES .....	13
COMMISSIONING OF THE CROSSFLOW SYSTEM .....	15
SETTING THE DELIVERY TEMPERATURE .....	15
SETTING THE GLOBE VALVE .....	16
CLEANING THE HEAT EXCHANGER.....	17
TROUBLE SHOOTING.....	17
THE RHEEM WARRANTY - GENERAL .....	19

---

**Notice to Victorian Customers from the  
Victorian Building Authority.**

**This heat exchange system must be installed by a licensed person as required by the Victorian Building Act 1993.**

Only a licensed person will give you a Compliance Certificate, showing that the work complies with all the relevant standards. Only a licensed person will have insurance protecting their workmanship for 6 years. Make sure you use a licensed person to install this water heater and ask for your Compliance Certificate.

**PATENTS**

This water heater may be protected by one or more patents or registered designs.

**TRADEMARKS**

® Registered trademark of Rheem Australia Pty Ltd.  
™ Trademark of Rheem Australia Pty Ltd.

**NOTE:** Every care has been taken to ensure accuracy in preparation of this publication. No liability can be accepted for any consequences, which may arise as a result of its application

## DESCRIPTION

The Rheem Crossflow™ Delivery Skid is used to instantaneously transfer heat from the primary circuit to the secondary or domestic hot water circuit without the need for further storage. A temperature controlled variable speed circulator for the primary fluid circuit is used to regulate the rate of energy transfer to the potable water. The Rheem Crossflow controls allow heat input up to 90°C to be supplied on the primary side and accurate, reduced temperature to be delivered on the potable side. The temperature setting is factory set but can be adjusted on site as required. The system is factory assembled and furnished with 316L stainless steel manifolds and fittings, the steel frame is fully welded and hot dip galvanised for superior corrosion resistance. The Rheem Crossflow is available in four sizes and two of the same size unit can be connected where further redundancy or greater capacity is required.

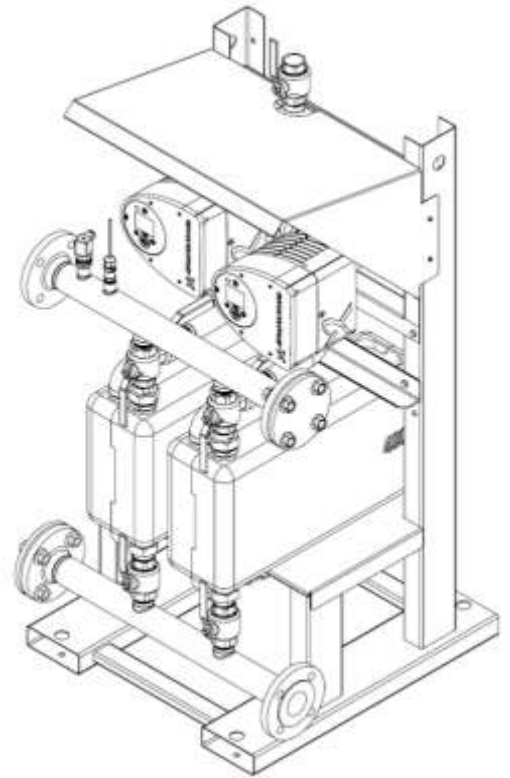

## PUMP

The Rheem Crossflow is fitted with a temperature controlled variable speed pump. There are two options available, these being a single head pump or a dual head pump to provide duty/standby redundancy.

## HEAT EXCHANGE

Each system is supplied with two WaterMark certified, 316L stainless steel single wall brazed plate-type heat exchangers. Each heat exchanger can be separately isolated and removed for individual maintenance, thus providing redundancy capability. The heat exchangers exhibit extremely low pressure loss and are insulated to maximise efficiency.



**THIS HEAT EXCHANGE SYSTEM IS NOT SUITABLE FOR APPLICATIONS WHERE REFRIGERANTS ARE USED AS THE HEATING SOURCE, OR WHERE THE PRESSURE IN THE NON-POTABLE SIDE OF THE HEAT EXCHANGER IS LIKELY TO EXCEED THE PRESSURE IN THE POTABLE SIDE.**

Table 1 – Crossflow System Specifications

Model		RD200	RD400	RD600	RD800	
Nominal Capacity		kW	200	400	600	800
Parameters for Nominal Capacity Rating	<b>Primary Side (non-potable)</b>					
	Inlet Temp	°C	80	80	80	80
	Flow Rate	L/min	48	114	144	186
	Pressure Drop	kPa	24	47	36	36
	<b>Secondary Side (potable)</b>					
	Inlet/Outlet Temp	°C	15/65	15/65	15/65	15/65
	Flow Rate	L/min	57	115	172	223
	Pressure Drop	kPa	37	47	51	48
Dimensions	H x W x D	mm	1364 x 761 x 700			
Weight		kg	130	138	147	156
Pipe Connections Primary Circuit	BSPF	RP1¼				
Pipe Connections Secondary Circuit		DN50 ISO EN 1092-1 11B PN40 Flange				
Max Operating Pressure Primary Circuit	kPa	1400*				
Max Operating Pressure Secondary Circuit	kPa	1400*				
Electrical Supply		230-240V 50/60Hz Hard Wired By Electrician				
Min Recommended Circuit Size	Amps	10				

\*The maximum working pressure of each side of the system will be governed by the lowest operating pressure appliance connected to it. The potable water side (secondary side) must be higher than the non-potable side (primary side).

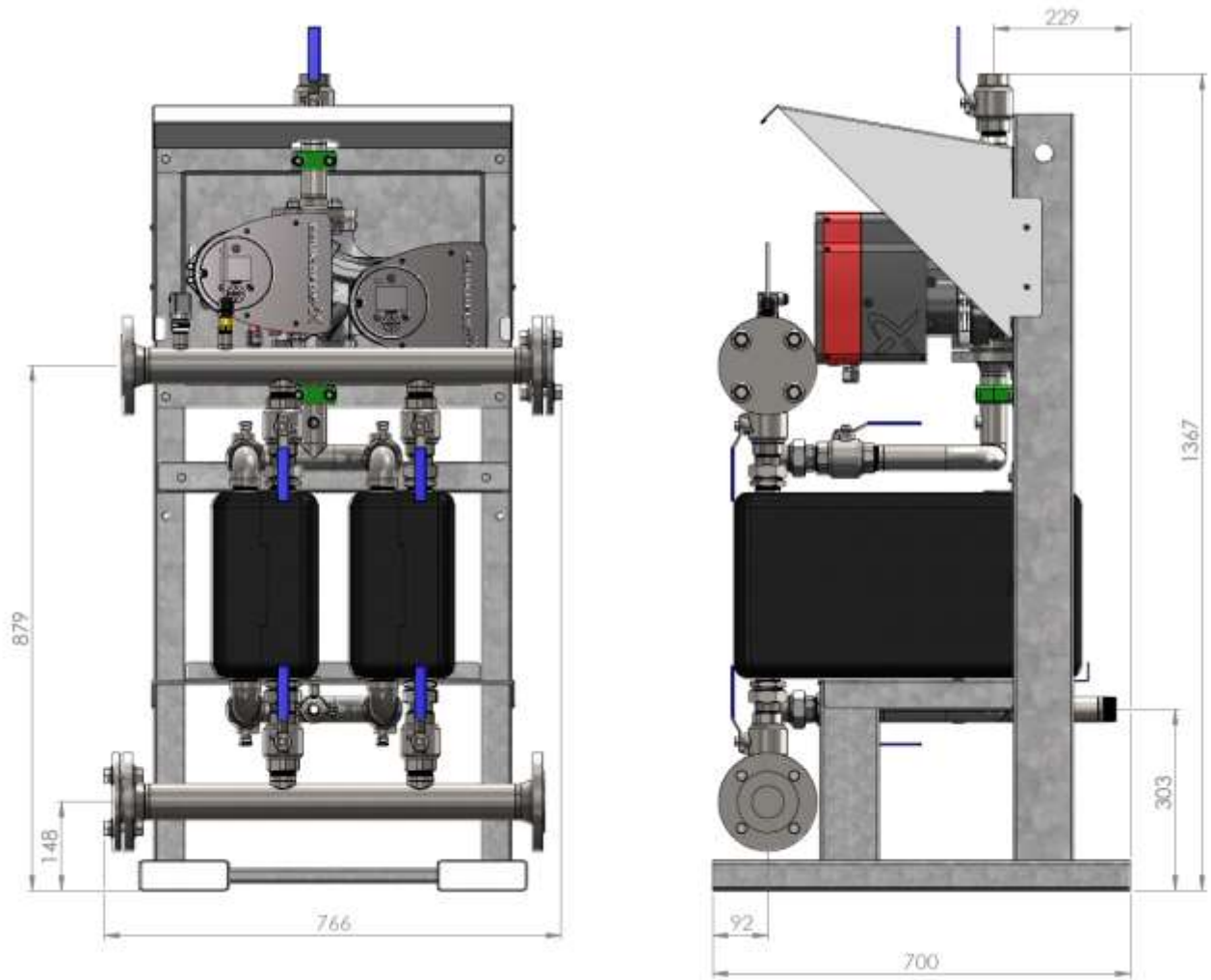

**Crossflow System Dimensions (Dual head pump model shown)**

**Table 2 – Crossflow System Output**

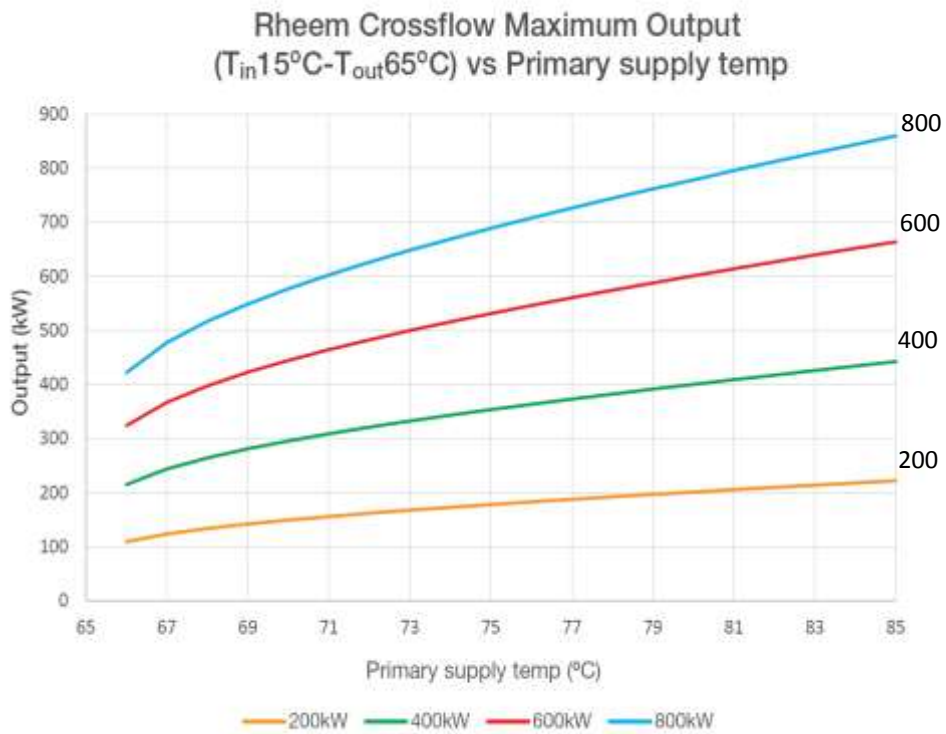

**Table 3 – Crossflow System Pressure Drop (Secondary Side)**

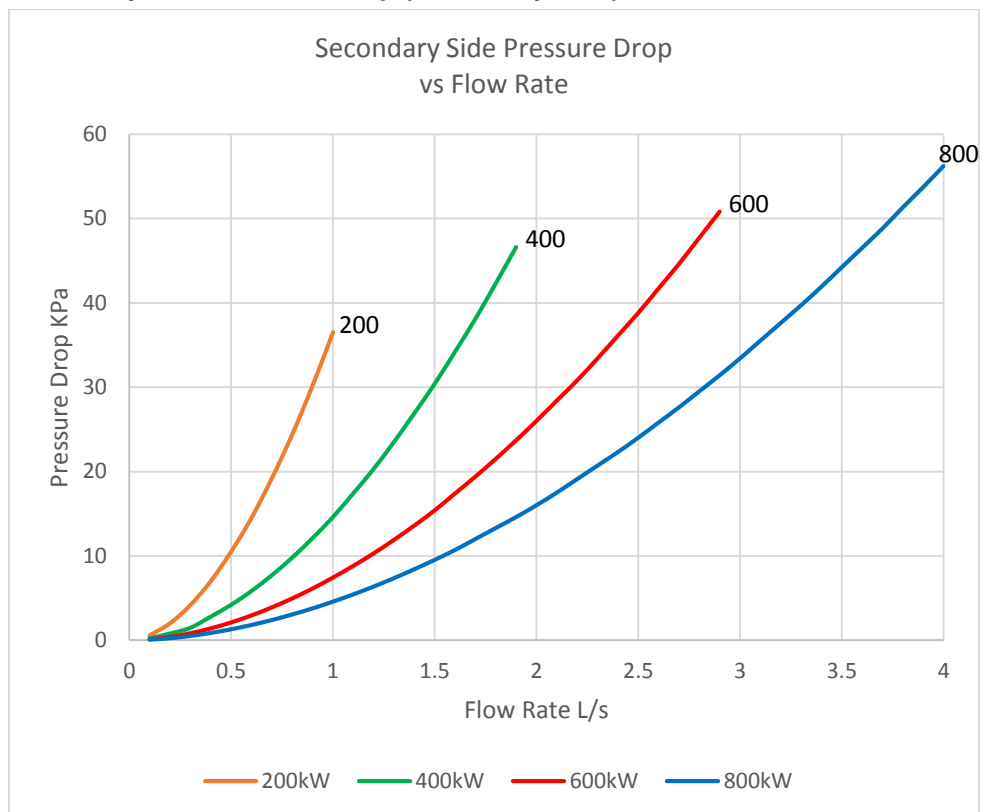

**Delivery Skid Secondary Side Flow Rate  
for Varying Primary Supply Temperatures and Secondary Side Temperature Rise**

200kW					
<b>Primary Temp</b>	85	80	75	70	65
<b>Output (kW)</b>	215	200	190	160	100
<b>Temp Rise</b>	<b>Secondary Side Flow Rate (L/min)</b>				
65	47	44	42	35	22
60	51	48	45	38	24
55	56	52	50	42	26
50	62	57	54	46	29
45	68	64	61	51	32
40	77	72	68	57	36
35	88	82	78	66	41

400kW					
<b>Primary Temp</b>	85	80	75	70	65
<b>Output (kW)</b>	450	400	365	300	200
<b>Temp Rise</b>	<b>Secondary Side Flow Rate (L/min)</b>				
65	99	88	80	66	44
60	108	96	87	72	48
55	117	104	95	78	52
50	129	115	105	86	57
45	143	127	116	96	64
40	161	143	131	108	72
35	184	164	149	123	82

600kW					
<b>Primary Temp</b>	85	80	75	70	65
<b>Output (kW)</b>	785	600	535	450	300
<b>Temp Rise</b>	<b>Secondary Side Flow Rate (L/min)</b>				
65	173	132	118	99	66
60	188	143	128	108	72
55	205	156	139	117	78
50	225	172	153	129	86
45	250	191	170	143	96
40	281	215	192	161	108
35	321	246	219	184	123

800kW					
<b>Primary Temp</b>	85	80	75	70	65
<b>Output (kW)</b>	870	800	695	680	400
<b>Temp Rise</b>	<b>Secondary Side Flow Rate (L/min)</b>				
65	192	176	153	150	88
60	208	191	166	162	96
55	227	208	181	177	104
50	249	229	199	195	115
45	277	255	221	217	127
40	312	287	249	244	143
35	356	328	285	278	164

2 x 600kW					
<b>Primary Temp</b>	85	80	75	70	65
<b>Output (kW)</b>	1570	1200	1070	900	600
<b>Temp Rise</b>	<b>Secondary Side Flow Rate (L/min)</b>				
65	346	265	236	198	132
60	375	287	256	215	143
55	409	313	279	235	156
50	450	344	307	258	172
45	500	382	341	287	191
40	563	430	383	323	215
35	643	491	438	369	246

2 x 800kW					
<b>Primary Temp</b>	85	80	75	70	65
<b>Output (kW)</b>	1740	1600	1390	1360	800
<b>Temp Rise</b>	<b>Secondary Side Flow Rate (L/min)</b>				
65	384	353	307	300	176
60	416	382	332	325	191
55	453	417	362	354	208
50	499	459	398	390	229
45	554	510	443	433	255
40	624	573	498	487	287
35	713	655	569	557	328



## SYSTEM INSTALLATION



### IMPORTANT:

It is the responsibility of the plumber/installer that all installations are made in accordance with the building, electrical, and plumbing codes applicable in the installation region.

## GENERAL REQUIREMENTS

### Codes and Regulations

Besides these instructions, all installations of the Rheem Crossflow system shall be carried out in accordance with:

- Local Regulations
- Municipal Building Codes
- Occupational Health, Safety & Welfare Regulations
- All plumbing work must be carried out by a qualified person and in accordance with the National Plumbing Standard AS/NZS 3500.4 and local authority requirements.
- All electrical work must be carried out by a qualified person and in accordance with AS/NZS 3000, as applicable under local regulations, and all local codes and regulatory authority requirements.
- In New Zealand the installation must also conform to the New Zealand Building Code.

### Permits

All correct permits shall be obtained from the appropriate regulatory authorities.

### Safety

Safety is the first priority in all installations. Please observe the safety warnings in this manual and other safety information provided on the HS Series system. Common safety precautions are:

- System must only be installed, commissioned or serviced by a qualified person.
- Depending on the model selected, the Crossflow system can be programmed by the installer to supply hot water at a temperature in excess of 50°C. We recommend that a temperature limiting device be fitted between the Crossflow system and the hot water outlets in any ablution and public areas such as bathrooms, ensuites or public amenities, to reduce the risk of scalding. A tempering valve may be required to comply with local requirements. Refer to the plumbing codes applicable in your area to determine if a temperature limiting device is required to minimize the risk of scalding.

## SYSTEM CONFIGURATION

Refer to the **Application Guide** for specific system layouts.

## CROSSFLOW PRIMARY CONNECTIONS

Position the Crossflow in the required location, as close to the heat source as possible and secure to the ground if required. Access to the Crossflow and removal of components is from the front, however sufficient clearance should be left on either side to allow for wrench access.

The Crossflow system is suitable for indoor or outdoor installation. In extreme climatic regions where ambient temperatures regularly exceed 40°C, it is recommended to install the Crossflow system out of direct sunlight.

The Crossflow requires a minimum of 1m head in order for the pump to function to specification. This requirement can be met in most situations. Minimum head may need to be considered when used with the primary circuit located in open vented or drain back systems.

Install a line strainer on the primary flow to the Crossflow marked “Heating Source In”. Pipe work must be cleared of foreign matter before connection and purged before attempting to operate the system. All olive compression fittings must use brass or copper olives.

Refer to [Delivery Skid Primary Side Pipe Sizing Chart on page 10](#) for pipe sizing between the heating source and the Crossflow. If more than 2 Crossflows are to be manifolded, or the pipe run exceeds a total of 10m flow and return between the Crossflow and the closest tank, or pipe material other than copper is being used, consult Rheem for appropriate pipe sizing.

Connect hot supply from heating source to the fitting marked “Heating Source In” on the Crossflow.

Install the globe valve (not required with 800kW model) at the connection marked “Heating Source Out” on the Crossflow.

Connect from the fitting marked “Heating Source Out” on the Crossflow to the heating source return. Refer to the Application Guide for specific system layouts.

Provision for expansion of the primary side circuit must be included in the primary circuit. This may be in the form of pressure relief in the storage tank or primary flow and return circuit or via an expansion tank or vessel.

If multiple Delivery Skids are to be manifolded together to provide greater flow rate capability, [follow the diagram on page 10](#). Ensure equal-friction method is used when making the plumbing connections. If more than 2 Delivery skids are to be manifolded, or the pipe run exceeds a total of 10m flow and return, consult Rheem for appropriate pipe sizing.

Refer to [Potable Water Connections to Crossflow System](#) on page 10 for potable water connection details.

### Multiple Crossflow System Manifolding

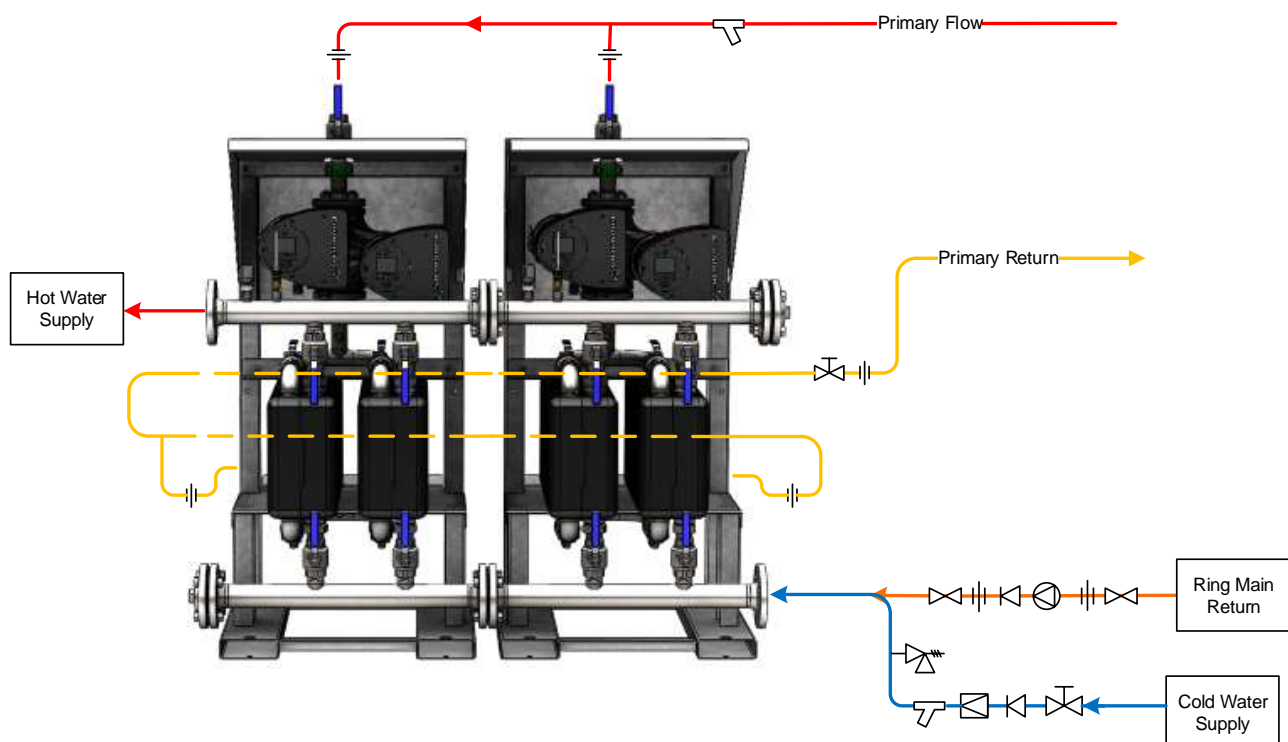

**Table 4 - Crossflow System Primary Side Pipe Sizing**

Crossflow system Model	Output (kW)	Pipe Size (copper) DN
200	200	40
400	400	50
600	600	65
800	800	80
2 x 600	1200	100
2 x 800	1600	100

### POTABLE WATER CONNECTIONS TO CROSSFLOW SYSTEM

[Refer to the diagram on page 10](#) for potable water connections.

All pipe work must be cleared of foreign matter before connection and purged before attempting to operate the system.

#### COLD WATER SUPPLY

Install an isolation valve, non-return valve, line strainer and expansion control valve (ECV) (not supplied) on the cold water supply to the Crossflow.

The pressure relief setting of the ECV should be no greater than the maximum operating pressure of the lowest pressure rated component of the plumbing system, eg, taps, valves, water heaters, other appliances, but **MUST NOT** exceed 1400kPa. The cold water supply pressure should be 20% below the ECV setting.

An acceptable arrangement is shown in the [diagram on page 10](#).

Connect the cold water supply at the flange marked "Potable In". The Crossflow system is supplied such that cold water enters on the right and leaves on the left. It is important that it remains this way to ensure accurate temperature reading at the hot water outlet.

#### HOT WATER SUPPLY

Depending on the model selected, the Crossflow system can be programmed by the installer to supply hot water at a temperature in excess of 50°C. We recommend that a temperature limiting device be fitted between the Crossflow system and the hot water outlets in any ablution and public areas such as bathrooms, ensuites or public amenities, to reduce the risk of scalding. A tempering valve may be required to comply with local requirements. Refer to the plumbing codes applicable in your area to determine if a temperature limiting device is required to minimize the risk of scalding.

Connect the hot water flow at the flange marked "Potable Out".

#### MULTIPLE INSTALLATIONS

If multiple Crossflows are to be manifolded together to provide greater flow rate capability, [follow the diagram on page 10](#). Ensure equal-friction method is used when making the plumbing connections. The potable water flanges may be joined together for up to two Crossflows. Systems greater than this require the potable water to be connected via a common header.

**PIPE INSULATION**

All hot water pipework shall be insulated to minimise heat losses. Use a minimum of 13 mm thick closed-cell polymer preformed pipe insulation or similar. Additionally, where temperatures reach -4°C for periods of greater than 8 hours, the potable cold water supply pipes shall be adequately insulated with at least 13 mm of closed-cell polymer insulation or equivalent. All insulation used shall be weatherproof and UV resistant if exposed, and protected from water ingress by tape, painting or sheathing.

**ELECTRICAL CONNECTIONS**

The Crossflow system is supplied pre-assembled and wired, however, requires connection of a correctly sized single phase power supply (including neutral 'N' and protective earth 'PE'). This power supply **SHALL BE** supplied from a distribution board (not supplied) that contains a circuit breaker and a main isolation switch to cut power to the control unit for servicing purposes. If the distribution board is not located close to the Crossflow, then a separate isolation switch **SHALL BE** installed in the power supply directly before it.

All electrical work and permanent wiring must be carried out by a qualified person and in accordance with the Wiring Rules AS/NZS 3000 and all local codes and regulatory authority requirements.



**Warning!** Do not connect the power supply cable to the mains voltage power supply until all connections have been made and the system has been charged with water. Failure to do so can lead to electric shock and/or failure of the pump.

**Table 5 - Crossflow system Electrical Requirements**

Model	Power Supply	Max Current (Amps)	Min Circuit Size (Amps)
SD200	220 -240V AC / 50-60Hz	5	10
SD400			
SD600			
SD800			

Wire the power supply to terminals L, N, Earth within the Crossflow system pump controller housing.

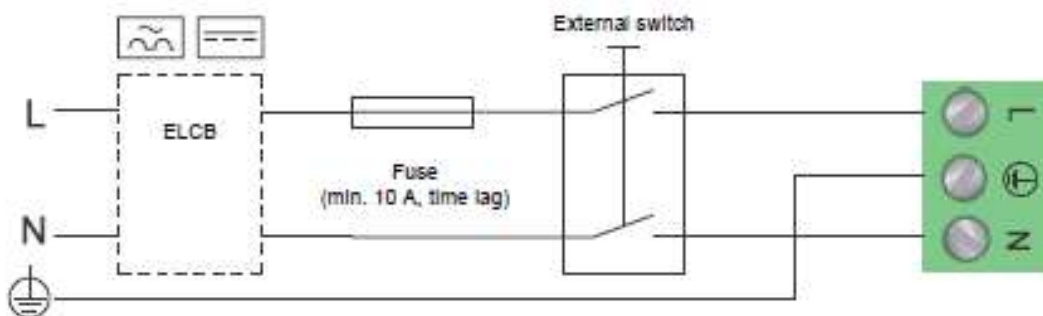

**Crossflow System Wiring**

## WATER SUPPLIES

**This Crossflow system must be installed in accordance with this advice to be covered by the Rheem warranty.**

The Crossflow system is manufactured to suit the water conditions of most public reticulated water supplies. However, there are some known water chemistries which can have detrimental effects on the heat exchanger system and its operation and / or life expectancy. If you are unsure of your water chemistry, you may be able to obtain information from your local water supply authority. This heat exchanger system should only be connected to a water supply which complies with these guidelines for the Rheem warranty to apply.

## CHANGE OF WATER SUPPLY

The changing or alternating from one water supply to another can have a detrimental effect on the operation and / or life expectation of a number of components in this heat exchanger system.

Where there is a changeover from one water supply to another, e.g. a rainwater tank supply, bore water supply, desalinated water supply, public reticulated water supply or water brought in from another supply, then water chemistry information should be sought from the supplier or it should be tested to ensure the water supply meets the requirements given in these guidelines for the Rheem warranty to apply.

## SATURATION INDEX

The saturation index (SI) is used as a measure of the water's corrosive or scaling properties.

Where the saturation index is less than  $-1.0$ , the water is very corrosive and the Rheem warranty does not apply to the heat exchanger system. In a corrosive water supply, the water can attack copper parts and cause them to fail.

Where the saturation index exceeds  $+0.40$ , the water is very scaling and an expansion control valve\* must be fitted on the cold water line after the non-return valve for the Rheem warranty to apply to a Rheem storage tank. The Rheem warranty does not apply to the heat exchanger.

Water which is scaling may be treated with a water softening device to reduce the saturation index.

## CHLORIDE AND PH

In a high chloride water supply, the water can corrode stainless steel parts and cause them to fail. Where the chloride level exceeds the limits shown in the table below the Rheem warranty does not apply to the Crossflow system.

CHLORIDE CONTENT	MAXIMUM TEMPERATURE			
	60°C	80°C	120°C	130°C
= 10 ppm	SS 304	SS 304	SS 304	SS 316
= 25 ppm	SS 304	SS 304	SS 316	SS 316
= 50 ppm	SS 304	SS 316	SS 316	Ti / 254 SMO
= 80 ppm	SS 316	SS 316	SS 316	Ti / 254 SMO
= 150 ppm	SS 316	SS 316	Ti / 254 SMO	Ti / 254 SMO
= 300 ppm	SS 316	Ti / 254 SMO	Ti / 254 SMO	Ti / 254 SMO
> 300 ppm	Ti / 254 SMO	Ti / 254 SMO	Ti / 254 SMO	Ti / 254 SMO

pH is a measure of whether the water is alkaline or acid. In an acidic water supply, the water can attack stainless steel parts and cause them to fail. Where the pH is less than the recommended level shown in the table of water content below, the Rheem warranty does not apply to the heat exchanger system.

Water with a low pH may be treated to raise the pH. The water supply from a rainwater tank in a metropolitan area is likely to be corrosive due to the dissolution of atmospheric contaminants.

**SUMMARY OF WATER CHEMISTRY ADVICE AFFECTING THE RHEEM WARRANTY**

The Crossflow system is not suitable for certain water chemistries. The following table is to be considered a guide to the corrosion resistance of stainless steels and brazing materials in tap water at room temperature. In the table a number of important chemical components are listed, however the actual corrosion is a very complex process influenced by many different components in combination.

Rheem's warranty will not cover any resultant faults if the water heater is connected at any time to a water supply that exceeds the limits listed in the table.

**EXPLANATIONS:** + Good resistance under normal conditions  
 0 Corrosion problems may occur especially when more factors are valued 0  
 - Use is not recommended

WATER CONTENT	CONCENTRATION (mg/l or ppm)	TIME LIMITS Analyze before	AISI 316	COPPER
Alkalinity (HCO <sup>-</sup> )	< 70	Within 24 h	+	0
	70-300		+	+
	> 300		+	0/+
Sulphate <sup>[1]</sup> (SO <sub>4</sub> <sup>2-</sup> )	< 70	No limit	+	+
	70-300		+	0/+
	> 300		+	-
HCO <sub>3</sub> <sup>-</sup> / SO <sub>4</sub> <sup>2-</sup>	> 1.0	No limit	+	+
	< 1.0		+	0/-
Electrical conductivity	< 10 µS/cm	No limit	+	0
	10-500 µS/cm		+	+
	> 500 µS/cm		+	0
pH [2]	< 6.0	Within 24 h	0	0
	6.0-7.5		+	0
	7.5-9.0		+	+
	>9.0		+	0
Ammonium (NH <sub>4</sub> <sup>+</sup> )	< 2	Within 24 h	+	+
	2-20		+	0
	>20		+	-
Chlorides (Cl <sup>-</sup> ) <i>Please also see table above</i>	<100		+	+
	100 - 200		+	+
	200 – 300		+	+
	>300		-	0/+
Free chlorine (Cl <sub>2</sub> )	<1	Within 5 h	+	+
	1 – 5		-	0
	>5		-	0/-
Hydrogen sulphide (H <sub>2</sub> S)	<0.05	No limit	+	+
	>0.05		+	0/-
Free (aggressive) carbon dioxide (CO <sub>2</sub> )	<5	No limit	+	+
	5 – 20		+	0
	>20		+	-
Total hardness (°dH)	4.0 – 8.5	No limit	+	+
Nitrate <sup>[1]</sup> (NO <sub>3</sub> <sup>-</sup> )	<100	No limit	+	+
	>100		+	0
Iron <sup>[3]</sup> (Fe)	<0.2	No limit	+	+
	>0.2		+	0
Aluminium (Al)	<0.2	No limit	+	+
	>0.2		+	0
Manganese <sup>[3]</sup> (Mn)	<0.1	No limit	+	+
	>0.1		+	0

[1] Sulfate and nitrate work as inhibitors for pitting corrosion caused by chlorides in pH neutral environments

[2] Low pH (below 6) increases corrosion risk and high pH (above 7.5) decreases the corrosion risk

[3] Fe and Mn are strong oxidants and may increase the risk for localised corrosion on stainless steels.

SiO<sub>2</sub> above 150ppm increases the risk of scaling

## COMMISSIONING OF THE CROSSFLOW SYSTEM

### Potable and Non-Potable Water Circuit

All lines must be flushed of debris prior to filling the system. Failure to observe this requirement may lead to system blockage and/or underperformance. Check and clean the line strainers after flushing.

Fill the potable water circuit by opening the isolation valve at the cold water inlet connection on the potable water side of the Crossflow. Open a hot tap so air may be purged from within the system whilst filling. Close hot tap when all air has been expelled.

Fill the non-potable water circuit by opening the isolation valve at the “Heating Source In” and “Heating Source Out” connections on the non-potable water side of the Crossflow. Ensure air is purged from within the system whilst filling.

When full operational pressure is reached, ensure that all connections on both circuits are free of leaks. The non-potable water circuit **MUST BE** full and pressurised before any other tests are conducted to avoid potentially damaging the Crossflow pump. Failure to observe this precaution will result in warranty being void.

Switch on the electrical power to the Crossflow and follow the instructions below to set the temperature.

### SETTING THE DELIVERY TEMPERATURE

The temperature entering the primary side of the Crossflow should be at least 5°C higher than the set temperature of the Crossflow in order for the Crossflow to perform to specification.

The Crossflow set point temperature should be at least 5°C below the ECO setting for the given model. Refer to table below for ECO temperature settings.

The Crossflow is supplied from the factory at the temperature described in the table below. If adjustment is required:

- Go to Home screen on the pump.
- Press OK. The setpoint box will be highlighted.
- Press OK. The temperature will be highlighted
- Press OK. The first digit will be highlighted. Use the Up/Down and Side keys to select the desired setpoint.
- Press the Return key to go back through the pages or the Home key to return to the home page.

### Delivery Skid Temperature Settings

Model	ECO Setting	Factory Setting	Max Recommended Temp Setting
/65	70	65	65

Refer to Grundfos Magna manual supplied with Crossflow for other system options.



## **SETTING THE GLOBE VALVE**

Before testing the system, the water heating plant must be at the set temperature.

If installed, and connected to the inlet of the Crossflow (refer to Application Guide), turn on the building recirculation pumps. If the Crossflow is connected on a dead leg circuit, open some taps to represent the design minimum flow rate. The Crossflow will automatically activate to heat the water in the secondary circuit to the set temperature.

If the pump does not activate, or shuts down soon afterwards, this is an indication the flow rate is at the lower end of the Crossflow pump operating range. This will be the case typically with 200 to 600kW Delivery Skids, with a high heating source temperature and a high return water temperature (ie small temperature rise).

Adjusting the globe valve on the Crossflow primary side outlet towards the closed position will allow the Crossflow pump to operate at a lower flow rate and maintain better temperature control (not supplied with 800kW Crossflow).

Adjust the globe valve so that the pump remains on for a longer period of time.

## **CROSSFLOW PARAMETER SETTINGS**

The Dual Head Pump Crossflow system is factory set to automatically switch pump operation in duty/standby mode and switch pumps in the event of pump failure. No further adjustments are required to the system.

The system is now completely commissioned. Explain operation and hand over to a responsible officer.



---

## **CLEANING THE HEAT EXCHANGER**

Should the heat exchanger require cleaning, e.g. due to operation in hard water at high temperatures, it is possible to clean the heat exchanger. Use a tank with weak acid, 5% phosphoric acid or, if the heat exchanger is frequently cleaned, 5% oxalic acid. Remove from the system and circulate cleaning fluid through the heat exchanger, ideally at 1.5 times the normal flow rate and in reverse flow.

Flush the heat exchanger water ways with clean water and then before the final rinse with water, rinse with a solution of 1-2% sodium hydroxide (NaOH) or sodium bicarbonate (NaHCO<sub>3</sub>) to neutralise all acid.

## **TROUBLE SHOOTING**

Check the items below before making a service call. You will be charged for attending to any condition or fault that is not related to manufacture or failure of a part.

### **“Insufficient Water Temperature”**

- Check for blown fuses or tripped circuit breakers.
- Has over-temperature lock-out occurred on the operating thermostats of the heating source?
- Temperature setting on the Crossflow incorrect.

### **“Insufficient Water Pressure”**

- Check line strainers for blockage (if fitted).
- Check water pressure before and after pressure limiting valve (if fitted). If possible, adjust pressure setting if too low. Replace valve if necessary.
- Ensure pressure limiting valve is of sufficient capacity to meet the requirements of the application.
- Is pipe sizing adequate to suit the application?
- Check all valves, heat exchangers and pipework for fouling or blockage.

---

This page is intentionally blank

---

## **RHEEM CROSSFLOW WARRANTY – AUSTRALIA ONLY**

---

### **1. CROSSFLOW MODELS RD200, RD400, RD600 & RD800**

#### **THE RHEEM WARRANTY - GENERAL**

- 1.1 This warranty is given by Rheem Australia Pty Limited ABN 21 098 823 511 of 1 Alan Street, Rydalmere New South Wales.
- 1.2 Rheem offer a trained and qualified national service network who will repair or replace components at the address of the water heater subject to the terms of the Rheem warranty. Rheem Service, in addition can provide preventative maintenance and advice on the operation of your water heater. The Rheem Service contact number is available 7 days a week on 131 031 with Service personnel available to take your call from 8am to 8pm daily (hours subject to change).
- 1.3 For details about this warranty, you can contact us on 131 031 or by email at [warrantyenquiry@rheem.com.au](mailto:warrantyenquiry@rheem.com.au) (not for service bookings).
- 1.4 The terms of this warranty and what is covered by it are set out in section 2 and 3 and apply to water heaters manufactured after 1st March 2016.
- 1.5 If a subsequent version of this warranty is published, the terms of that warranty and what is covered by it will apply to water heaters manufactured after the date specified in the subsequent version.

### **2. TERMS OF THE RHEEM WARRANTY AND EXCLUSIONS TO IT**

- 2.1 The decision of whether to repair or replace a faulty component is at Rheem's sole discretion.
- 2.2 Where a failed component or cylinder is replaced under this warranty, the balance of the original warranty period will remain effective. The replacement does not carry a new Rheem warranty.
- 2.3 Where the water heater is installed outside the boundaries of a metropolitan area as defined by Rheem or further than 25 km from either a regional Rheem branch office or an Accredited Rheem Service Agent's office, the cost of transport, insurance and travelling between the nearest branch office or Rheem Accredited Service Agent's office and the installed site shall be the owner's responsibility.
- 2.4 Where the water heater is installed in a position that does not allow safe or ready access, the cost of that access, including the cost of additional materials handling and/or safety equipment, shall be the owner's responsibility. In other words, the cost of dismantling or removing cupboards, doors or walls and the cost of any special equipment to bring the water heater to floor or ground level or to a serviceable position is not covered by this warranty.
- 2.5 This warranty only applies to the original and genuine Rheem water heater in its original installed location and any genuine Rheem replacement parts.
- 2.6 If the water heater is not sized to supply the hot water demand in accordance with the guidelines in Rheem's water heater literature, any resultant fault will not be covered by the Rheem warranty.
- 2.7 The Rheem warranty does not cover faults that are a result of:
  - a) Accidental damage to the water heater or any component (for example: (i) Acts of God such as floods, storms, fires, lightning strikes and the like; and (ii) third party acts or omissions).
  - b) Misuse or abnormal use of the water heater.
  - c) Installation not in accordance with the Owner's Guide and Installation Instructions or with relevant statutory and local requirements in the State or Territory in which the water heater is installed.
  - d) Connection at any time to a water supply that does not comply with the water supply guidelines as outlined in the Owner's Guide and Installation Instructions.
  - e) Repairs, attempts to repair or modifications to the water heater by a person other than Rheem Service or a Rheem Accredited Service Agent.
  - f) Faulty plumbing or faulty gas or power supply.
  - g) Failure to maintain the water heater in accordance with the Owner's Guide and Installation Instructions.
  - h) Transport damage.
  - i) Fair wear and tear from adverse conditions (for example, corrosion).
  - j) Cosmetic defects.
  - k) Ice formation in the waterways of a water heater: where the electricity supply has been switched off or has failed and the water heater has not been drained in accordance with the instructions; or due to an ambient temperature below -20°C (including wind chill factor).
- 2.8 If you require a call out and we find that the fault is not covered by the Rheem warranty, you are responsible for our standard call out charge. If you wish to have the relevant component repaired or replaced by Rheem, that service will be at your cost.
- 2.9 Subject to any statutory provisions to the contrary, this warranty excludes any and all claims for damage to furniture, carpet, walls, foundations or any other consequential loss either directly or indirectly due to leakage from the water heater, or due to leakage from fittings and/ or pipe work of metal, plastic or other materials caused by water temperature, workmanship or other modes of failure.

### 3. WHAT IS COVERED BY THE RHEEM WARRANTY FOR THE CROSSFLOW IS DETAILED IN THIS DOCUMENT

- 3.1 Rheem will repair or replace a faulty component of your Crossflow Delivery Skid if it fails to operate in accordance with its specifications as follows:

What components are covered	The period in which the fault must appear in order to be covered	What coverage you receive
All components	Year 1	Repair and/or replacement of the faulty component, free of charge, including labour.
Heat exchanger	Years 2 to 5	New parts, free of charge, with installation and labour costs being the responsibility of the owner.

### 4. ENTITLEMENT TO MAKE A CLAIM UNDER THIS WARRANTY

- 4.1 To be entitled to make a claim under this warranty you need to:
- Be the owner of the water heater or have consent of the owner to act on their behalf.
  - Contact Rheem Service without undue delay after detection of the defect and, in any event, within the applicable warranty period.
- 4.2 You are **not** entitled to make a claim under this warranty if your water heater:
- Does not have its original serial numbers or rating labels.
  - Is not installed in Australia.

### 5. HOW TO MAKE A CLAIM UNDER THIS WARRANTY

- 5.1 If you wish to make a claim under this warranty, you need to:
- Contact Rheem on 131031 and provide owner's details, address of the water heater, a contact number and date of installation of the water heater or if that's unavailable, the date of manufacture and serial number (from the rating label on the water heater).
  - Rheem will arrange for the water heater to be tested and assessed on-site.
  - If Rheem determines that you have a valid warranty claim, Rheem will repair or replace the faulty component in accordance with this warranty.
  - Any expenses incurred in the making of a claim under this warranty will be borne by you.

### 6. THE AUSTRALIAN CONSUMER LAW

- 6.1 Our goods come with guarantees that cannot be excluded under the *Australian Consumer Law*. You are entitled to a replacement or refund for a major failure and for compensation for any other reasonably foreseeable loss or damage. You are also entitled to have the goods repaired or replaced if the goods fail to be of acceptable quality and the failure does not amount to a major failure.
- 6.2 The Rheem warranty (set out above) is in addition to any rights and remedies that you may have under the *Australian Consumer Law*.

**RHEEM AUSTRALIA PTY LTD**  
A.B.N. 21 098 823 511  
www.rheem.com.au

FOR SERVICE TELEPHONE  
**131 031 AUSTRALIA**  
**0800 657 335 NEW ZEALAND**