

SolarTerrace III-A

Code-Compliant Planning and Installation V 3.3
Complying with AS/NZS1170.2-2011 AMDT 2-2012



Introduction

Clenergy PV-ezRack® SolarTerrace III-A is a pre-assembled ground mount system suitable for large scale commercial and utility scale installations. PV-ezRack® SolarTerrace III-A has been developed to fit any PV module. The innovative and patented SolarTerrace III-A T-Rails simplify and improve the accuracy of the installation. Using high quality engineered components SolarTerrace III-A saves developers and installers, time and money when delivering large scale projects.

Please review this manual thoroughly before installing your SolarTerrace III-A system. This manual provides

1) Simple introduction of the installation relating to PV-ezRack® SolarTerrace III-A Mounting systems.

2) Planning and installation instructions for SolarTerrace III-A.

SolarTerrace III-A parts, when installed in accordance with this guide, will be structurally sound and meet the AS/NZS 1170.2:2011 (R2016) standard. During installation and especially when working on the roof, please comply with the appropriate safety regulations, and please also comply with the relevant regulations of your local region.

Please check that you are using the current version of the Installation Manual by contacting Clenergy Australia by email on www.clenergy.com.au or your local representative.

Product Warranty:

Please refer [PV-ezRack® Product Warranty](#) on our website.

List of contents

Introduction	01
Planning	02
Tools & Components	11
System Overview	13
Installation Instruction	15
Cetification	31

The installer is solely responsible for:

- Complying with all applicable local or national building codes, including any that may supersede this manual;
- Ensuring that PV-ezRack® and other products are appropriate for the particular installation and the installation environment;
- Using only PV-ezRack® parts and in staller supplied parts as specified by PV-ezRack® (substitution of parts may void the warranty and invalidate the letter of certification on page 2);
- Recycle according to the local relative statute;
- Removal: Reverse installation process;
- Ensure that there are no less than two professionals working on panel installation;
- Ensure the installation of all electrical equipment is performed by licensed electricians;
- Ensuring safe installation of all electrical aspects of the PV array. This includes providing adequate earth bonding of the PV array and PV- ezRack® SolarTerrace III-A components as required in AS/NZS 5033: 2021.

Planning

Installation Spacing and Concrete Footing Options

Tables 1-3 and 4-6 below, provide the maximum support spacing and concrete footing options in different wind regions for 60 cell panels (up to 1700 x 1400mm panel size) and 72 cell panels (up to 2000 x 1400mm panel size) respectively.

Table 1: Maximum Support Spacing and Footing Options in Wind Region A (Panels 1700 x 1400mm)

Wind Region	A			
Regional Wind Speed (m/s)	41			
Panels Tilt Angle	20°		30°	
Max Spacing (m)	3.75		3.25	
Footing Type	Concrete Footing Options (min N25)			
	Front Leg	Rear Leg	Front Leg	Rear Leg
Continuous Paving Slab (LxT) (m)	2.20 x 0.15		2.40 x 0.19	
Continuous Strip Footing (WxD) (m)	0.30 x 0.40	0.35 x 0.40	0.35 x 0.50	0.45 x 0.50
Individual Pad Footing per Leg (B xCxX) (m)	0.45 x 0.45 x 0.55	0.50 x 0.50 x 0.55	0.85 x 0.85 x 0.90	0.90 x 0.90 x 0.90
Transverse Strip Footing (LxAxD) (m)	2.20 x 0.60 x 0.60		2.50 x 0.70 x 0.70	

Table 2: Maximum Support Spacing and Footing Options in Wind Region B (Panels 1700 x 1400mm)

Wind Region	B			
Regional Wind Speed (m/s)	48			
Panels Tilt Angle	20°		30°	
Max Spacing (m)	3.65		3.15	
Footing Type	Concrete Footing Options (min N25)			
	Front Leg	Rear Leg	Front Leg	Rear Leg
Continuous Paving Slab (LxT) (m)	2.20 x 0.15		2.40 x 0.19	
Continuous Strip Footing (WxD) (m)	0.35 x 0.45	0.40 x 0.45	0.50 x 0.58	0.58 x 0.58
Individual Pad Footing per Leg (BxCxX) (m)	0.50 x 0.50 x 0.60	0.60 x 0.60 x 0.60	0.90 x 0.90 x 0.90	1.0 x 1.0 x 0.90
Transverse Strip Footing (LxAxD) (m)	2.35 x 0.65 x 0.65		2.75 x 0.75 x 0.75	

Table 3: Maximum Support Spacing and Footing Options in Wind Regions C & D (Panels 1700 x 1400mm)

Wind Region	C		D	
Regional Wind Speed (m/s)	59		73	
Panels Tilt Angle	20°		20°	
Max Spacing (m)	3.20		2.70	
Footing Type	Concrete Footing Options (min N25)			
	Front Leg	Rear Leg	Front Leg	Rear Leg
Continuous Paving Slab (LxT) (m)	2.20 x 0.19		2.40 x 0.25	
Continuous Strip Footing (WxD) (m)	0.50 x 0.50	0.50 x 0.50	0.55 x 0.65	0.60 x 0.65
Individual Pad Footing per Leg (BxCxX) (m)	0.60 x 0.60 x 0.65	0.65 x 0.65 x 0.65	0.70 x 0.70 x 0.75	0.70 x 0.70 x 0.75
Transverse Strip Footing (LxAxD) (m)	2.40 x 0.75 x 0.75		2.70 x 0.80 x 0.80	

Table 4: Maximum Support Spacing and Footing Options in Wind Region A (Panels 2000 x 1400mm)

Wind Region	A			
Regional Wind Speed (m/s)	41			
Panels Tilt Angle	20°		30°	
Max Spacing (m)	3.60		3.10	
Footing Type	Concrete Footing Options (min N25)			
	Front Leg	Rear Leg	Front Leg	Rear Leg
Continuous Paving Slab (LxT) (m)	2.30 x 0.15		2.30 x 0.20	
Continuous Strip Footing (WxD) (m)	0.30 x 0.40	0.35 x 0.40	0.35 x 0.55	0.55 x 0.55
Individual Pad Footing per Leg (BxCxX) (m)	0.50 x 0.50 x 0.60	0.70 x 0.70 x 0.60	0.85 x 0.85 x 0.90	0.95 x 0.95 x 0.90
Transverse Strip Footing (LxAxD) (m)	2.30 x 0.75 x 0.60		2.50 x 0.80 x 0.80	

Table 5: Maximum Support Spacing and Footing Options in Wind Region B (Panels 2000 x 1400mm)

Wind Region	B			
Regional Wind Speed (m/s)	48			
Panels Tilt Angle	20°		30°	
Max Spacing (m)	3.50		2.95	
Footing Type	Concrete Footing Options (min N25)			
	Front Leg	Rear Leg	Front Leg	Rear Leg
Continuous Paving Slab (LxT) (m)	2.30 x 0.20		2.40 x 0.25	
Continuous Strip Footing (WxD) (m)	0.35 x 0.45	0.45 x 0.45	0.55 x 0.65	0.65 x 0.65
Individual Pad Footing per Leg (BxCxX) (m)	0.55 x 0.55 x 0.75	0.75 x 0.75 x 0.75	0.95 x 0.95 x 0.90	1.05 x 1.05 x 0.90
Transverse Strip Footing (LxAxD) (m)	2.50 x 0.75 x 0.70		2.85 x 0.85 x 0.80	

Table 6: Maximum Support Spacing and Footing Options in Wind Regions C & D (Panels 2000 x 1400mm)

Wind Region	C		D	
Regional Wind Speed (m/s)	59		73	
Panels Tilt Angle	20°		20°	
Max Spacing (m)	3.00		2.00(1.90*)	
Footing Type	Concrete Footing Options (min N25)			
	Front Leg	Rear Leg	Front Leg	Rear Leg
Continuous Paving Slab (LxT) (m)	2.40 x 0.25		2.65 x 0.30	
Continuous Strip Footing (WxD) (m)	0.50 x 0.55	0.55 x 0.55	0.55 x 0.60	0.70 x 0.60
Individual Pad Footing per Leg (BxCxX) (m)	0.60 x 0.60 x 0.75	0.75 x 0.75 x 0.75	0.70 x 0.70 x 0.75	0.80 x 0.80 x 0.75
Transverse Strip Footing (LxAxD) (m)	2.70 x 0.85 x 0.80		2.90 x 0.80 x 0.80	

Note(*) :

When using east west adaptor.

Footings Summary

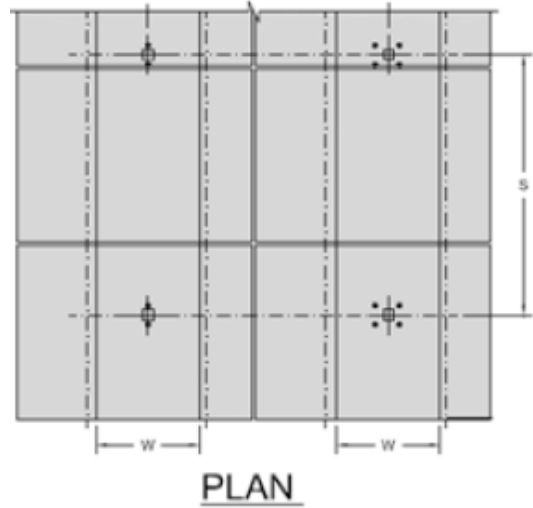
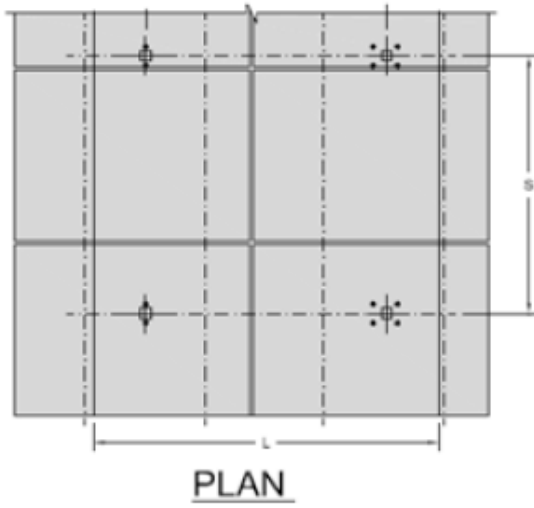
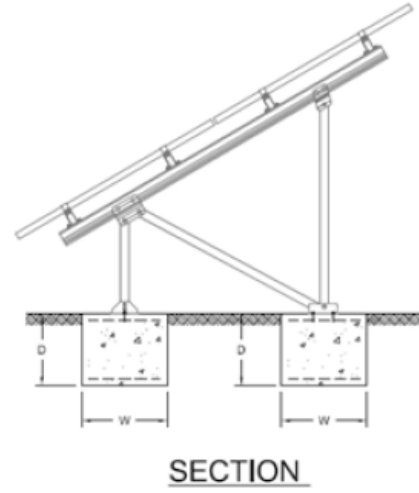
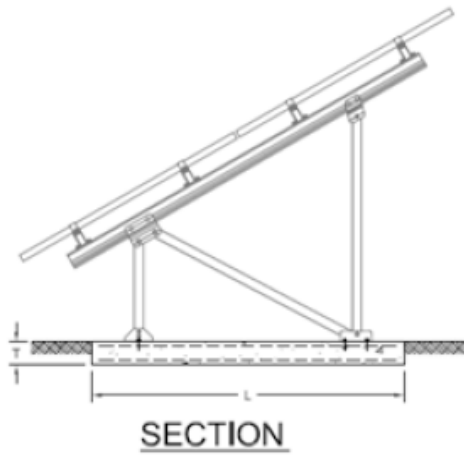

Continuous Paving Slab

Continuous Strip Footing

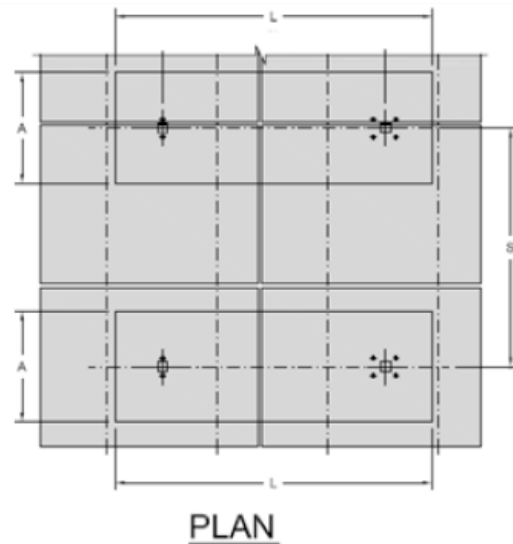
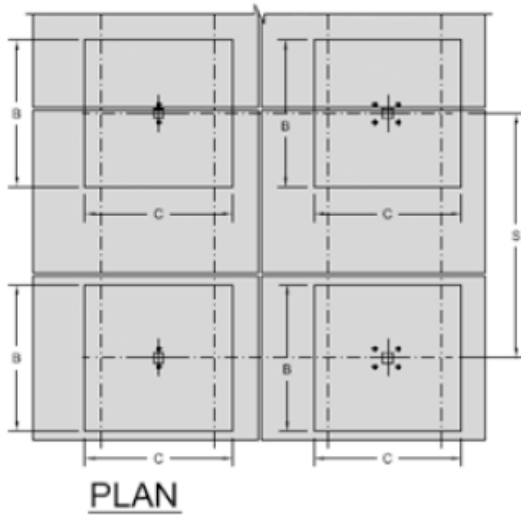
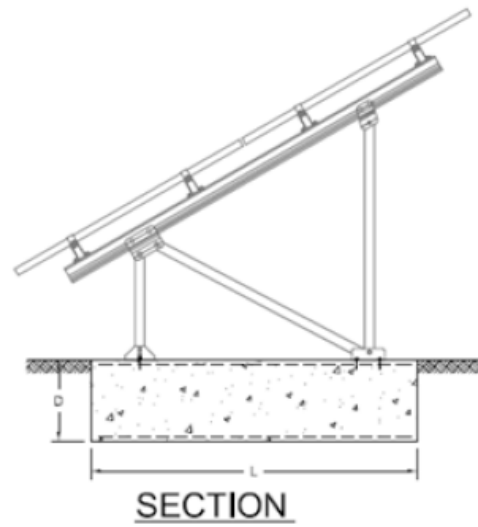
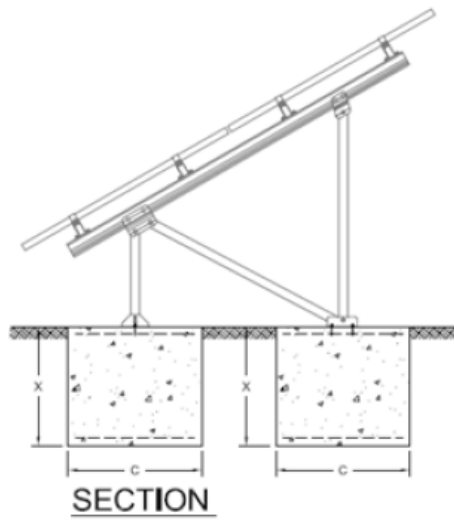

Individual Pad Footings per Leg

Transverse Strip Footing

Notes:

- The footing example shown are recommended for “firm” soils with allowable endbearing capacity of 100 kPa minimum (damp clays, sandy clays, damp sands). Contact Clenergy for site specific conditions (to find out whether a more cost effective solution is possible);
- Concrete grade: N25 minimum, cover: 50 mm (contact Clenergy to find out whether a more cost effective solution is possible, based on site specific conditions);
- For fixing the STIII-A support to the concrete footing, we recommend using M16(5.8 grade Carbon Steel anchor studs or similar). Adopt the minimum anchor embedment depth designated by the anchors manufacturer’s manual. Clenergy STIII-A has 6 anchors per frame, 2 at the front and 4 at the rear;
- Rail end overhang should be not over 40% of the support spacing.
- Other footing options are possible – contact Clenergy.

Ground Clearance

The ground clearances to the panels and the concrete base (CL and h mm) using four concrete footing options at different wind regions are presented in the tables below. CL is the height from the bottom of the lower panel to the ground and h is the height from the top of the concrete to the ground. (See the diagrams on page 10).

Table1: Ground Clearance in Wind Region A (Panels up to 1700 x 1200mm)

Wind Region	A			
	20°		30°	
Panels Tilt Angle	20°		30°	
Max Spacing (m)	3.75		3.25	
	CL (mm)	h (mm)	CL (mm)	h (mm)
Continuous Paving Slab	500	0	500	0
Continuous Strip Footing	700	200	500	0
Individual Pad Footing per Leg	700	200	800	300
Transverse Strip Footing	900	400	800	300

Table2: Ground Clearance in Wind Region A (Panels up to 1700 x 1200mm)

Wind Region	B			
	20°		30°	
Panels Tilt Angle	20°		30°	
Max Spacing (m)	3.65		3.15	
	CL (mm)	h (mm)	CL (mm)	h (mm)
Continuous Paving Slab	500	0	500	0
Continuous Strip Footing	700	200	700	200
Individual Pad Footing per Leg	800	300	900	400
Transverse Strip Footing	600	100	600	100

Table 3: Ground Clearance in Wind Region C & D (Panels up to 1700 x 1200mm)

Wind Region	C		D	
	20°		20°	
Panels Tilt Angle	20°		20°	
Max Spacing (m)	3.20		2.70	
	CL (mm)	h (mm)	CL (mm)	h (mm)
Continuous Paving Slab	500	0	500	0
Continuous Strip Footing	700	200	600	100
Individual Pad Footing per Leg	700	200	700	200
Transverse Strip Footing	600	100	600	100

Table 4: Ground Clearance in Wind Region A (Panels up to 2000 x 1200mm)

Wind Region	A			
	20°		30°	
Panels Tilt Angle	20°		30°	
Max Spacing (m)	3.60		3.10	
	CL (mm)	h (mm)	CL (mm)	h (mm)
Continuous Paving Slab	500	0	500	0
Continuous Strip Footing	700	200	700	200
Individual Pad Footing per Leg	700	200	900	400
Transverse Strip Footing	600	100	700	200

Table 5: Ground Clearance in Wind Region B (Panels up to 2000 x 1200mm)

Wind Region	B			
	20°		30°	
Panels Tilt Angle	20°		30°	
Max Spacing (m)	3.50		2.95	
	CL (mm)	h (mm)	CL (mm)	h (mm)
Continuous Paving Slab	500	0	500	0
Continuous Strip Footing	700	200	700	200
Individual Pad Footing per Leg	800	300	900	400
Transverse Strip Footing	600	100	600	100

Table 6: Ground Clearance in Wind Region C & D (Panels up to 2000 x 1200mm)

Wind Region	C		D	
	20°		20°	
Panels Tilt Angle	20°		20°	
Max Spacing (m)	3.00		2.45	
	CL (mm)	h (mm)	CL (mm)	h (mm)
Continuous Paving Slab	500	0	500	0
Continuous Strip Footing	700	200	600	100
Individual Pad Footing per Leg	700	200	700	200
Transverse Strip Footing	900	400	1000	500



Continuous Paving Slab

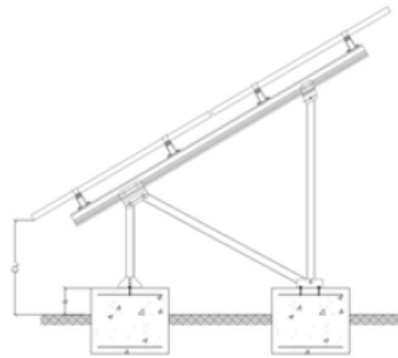

Continuous Strip Footing

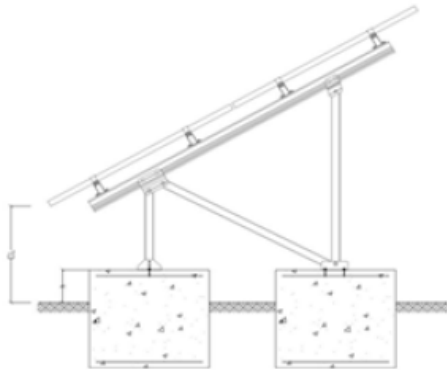

Individual Pad Footing per Leg

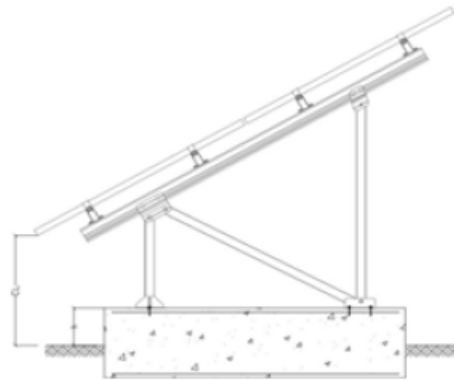

Transverse Strip Footing

Range of Adjustment

The system can be adjusted using the anchor plates below. Table 2.3.1 below indicates the range of adjustment depending on the front or rear legs and if you are using either a U or L anchor plate.

Installation with Concrete Foundation		
Adjustable area	Adjustable part	Adjustable Range
Front leg Up-down	Corrugated U-anchor Plate	± 20mm
Front leg Up-down	Corrugated U-anchor Plate	± 7.5mm
Front leg East-West	NA	--
Rearleg Up-down	Corrugated L-anchor Plate	
Rearleg North-South	Corrugated L-anchor Plate	± 20mm
Rearleg East-West	NA	± 7.5mm

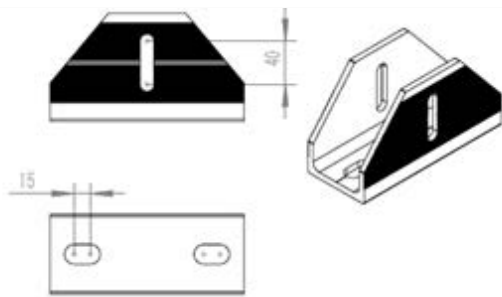

Corrugated U-anchor Plate (at Front leg)

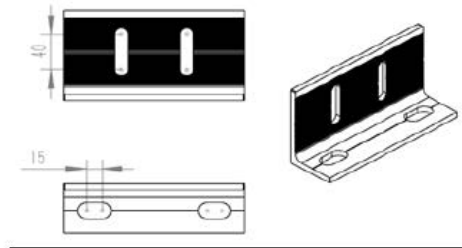









Corrugated L-anchor Plate (at Rear leg)

Depending on the system design, there is another option to concrete footings and that is using Ground Screw methodology, which is defined in more detail on pages 25-27. The table below defines the range of adjustments for the support structure when using this method.



Installation with Ground Screw		
Adjustable area	Adjustable part	Adjustable Range
Front leg Up-down	NA	--
Front leg North-South	Ground Screw	± 7.5mm
Front leg East-West	NA	--
Rearleg Up-down	NA	--
Rearleg North-South	Ground Screw	± 7.5mm
Rearleg East-West	NA	--

Tools and Components

Tools

				
Allen Key 6 mm (M8Hexagon Socket Screw)	Electric Drill (ST4.8x16 self-tapping screw & M8Hexagon Socket Screw)	Tape	Torque Wrench	String
				
Mark Pen	Wrench	Socket Wrench M8/M12	Total Station or Equivalent Instrument	

Components

				
ER-EC-ST End Clamp	ER-IC-ST Inter Clamp	ER-R-T110 T -Rail110	ER-SP-T110 Splice for T-110 Rail	ER-RC-T/G Rail Clamp for T Rail with Grounding
				
ER-S-STIIIA Support (Pre-assembled)	ER-CAP-T110 Cap for T-110 Rail	ER-CAP-G/A Cap for Square Girder	EZ-GC-ST Grounding Clip	EZ-GL-ST Grounding Lug

Components

		
<p>C-U/30/46-G Universal Clamp for Frame Height 30-46mm with Grounding Clip</p>	<p>C-U/30/46 Universal Clamp for Frame Height 30-46mm</p>	<p>BR-R110/EW/G (Optional) PV-ezRack® East/West Adjustable Bracket for T-Rail 110 with grounding</p>

System Overview

Overview of PV-ezRack® SolarTerrace III-A

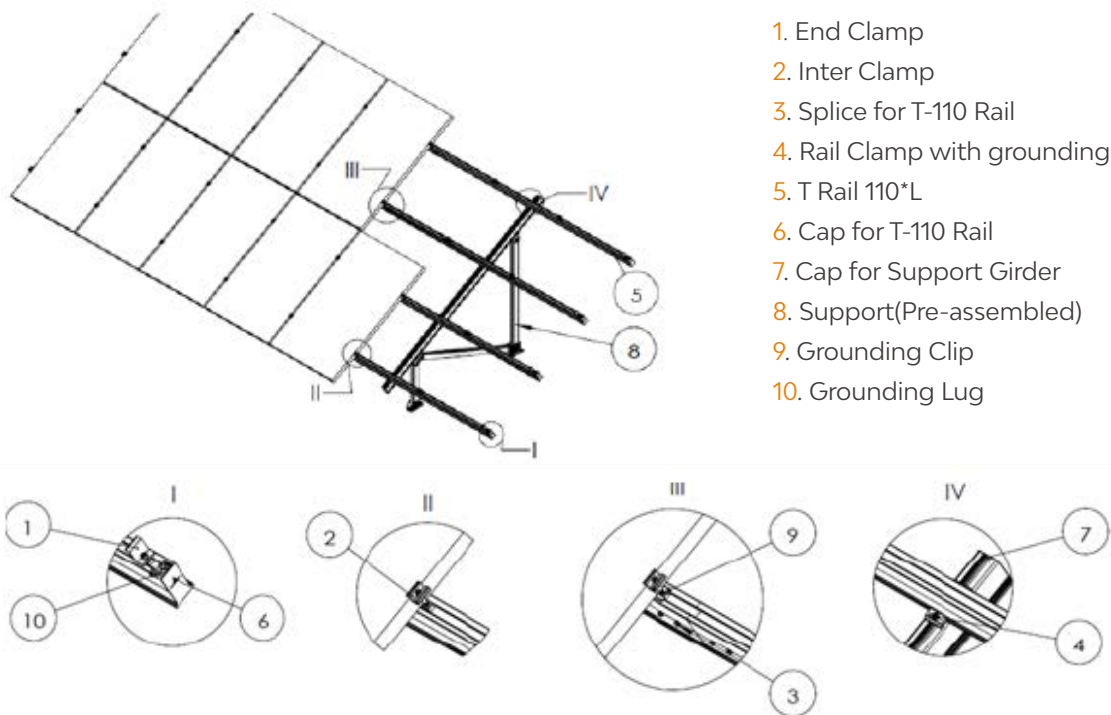

Precautions during Stainless Steel Fastener Installation

Improper operation may lead to deadlock of Nuts and Bolts. The steps below should be applied to stainless steel nut and bolt assembly to reduce this risk.

General installation instructions

- (1) Apply force to fasteners in the direction of thread
- (2) Apply force uniformly, to maintain the required torque
- (3) Professional tools and tool belts are recommended
- (4) In some cases, fasteners could be seized over time. As an option, if want to avoid galling or seizing of thread, apply lubricant (grease or 40# engine oil) to fasteners prior to tightening.

Safe Torques

Please refer to safe torques defined in this guide as shown in the figure below. If power tools are required, Clenergy recommends the use of low speed only. High speed and impact drivers increase the risk of bolt galling (deadlock). If deadlock occurs and you need to cut fasteners, please make sure that there is no load on the fastener before you cut it. Avoid damaging the anodized or galvanized surfaces.

These steps should be applied for every stainless steel nut and bolt assembly.

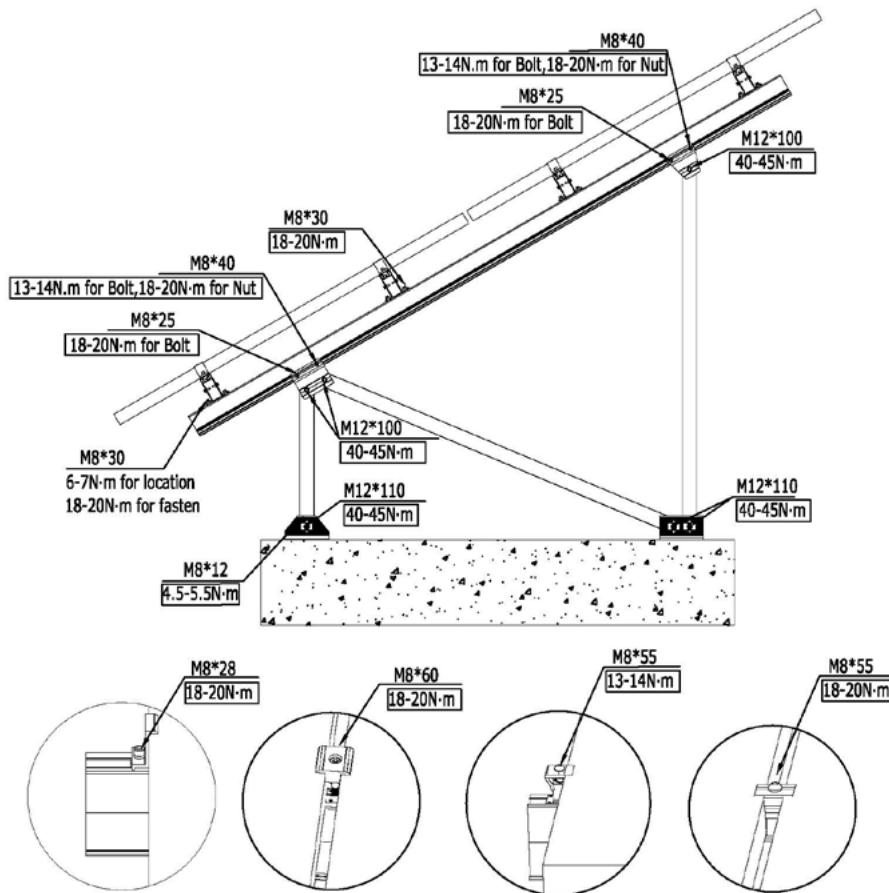

Safe Torques

Installation Dimensions

All drawings and dimensions in this installation guide are for a generic reference. PV-ezRack® SolarTerrace III-A is to be optimized to suit specific conditions for each project and documented in a construction drawing. As a result, major components of PV-ezRack® SolarTerrace III-A may be provided in section sizes and lengths that vary from those shown in this guide. The installation process detailed in this instruction guide remains the same regardless of the component size. In case you need to do any on-site modifications or alteration of the system in a way that would be different from the construction drawing please provide marked up drawings/sketches for Clenergy’s review prior modification for comment and approval.

Installation Instructions

Introduction

Solar Terrace III-A with Concrete Footing

Below are the side view drawings of support for 60 cell panels (up to 1700 x 1400 mm) and 72 cell panels (up to 2000 x 1400 mm) at 20° and 30° tilt angles.

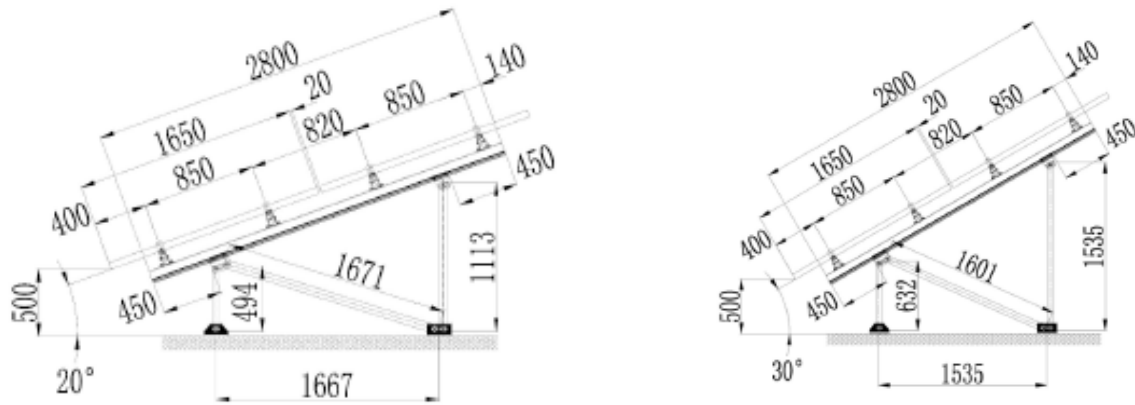

Side view drawings of support for 60 cell panels (up to 1700 x 1400mm)

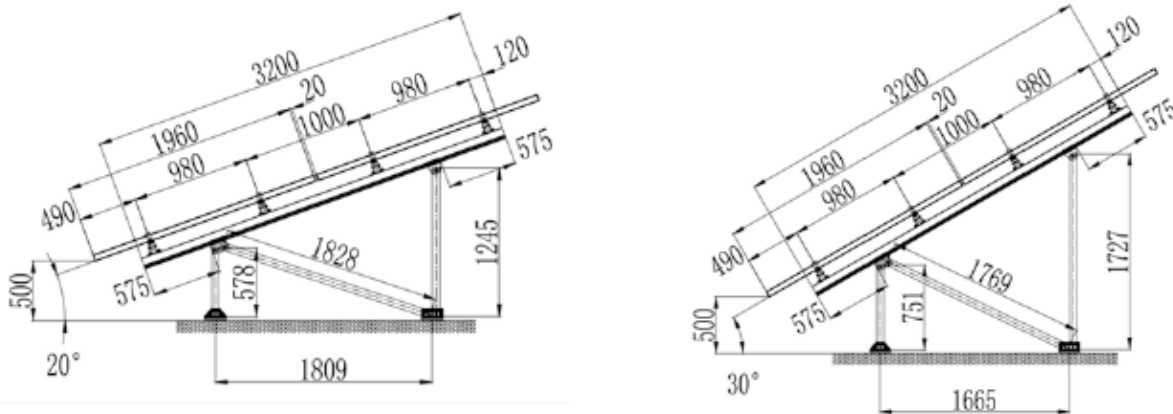

Side view drawings of support for 72 cell panels (up to 2000 x 1400mm)



Location Plan of Anchors (DS is the distance between the front leg and rear leg)

PLEASE NOTE THE DISTANCE BETWEEN FRONT LEG AND REAR LEG COULD BE DIFFERENT FOR OTHER TILT ANGLES OR FOR OTHER GIRDER LENGTHS. PLEASE CONTACT CLENERGY FOR CONFIRMATION.

Solar Terrace III-A with Concrete Footing

Below are the side view drawings of support for 60 cell panels (up to 1700 x 1400 mm) and 72 cell panels (up to 2000 x 1400 mm) at 20° and 30° tilt angles.

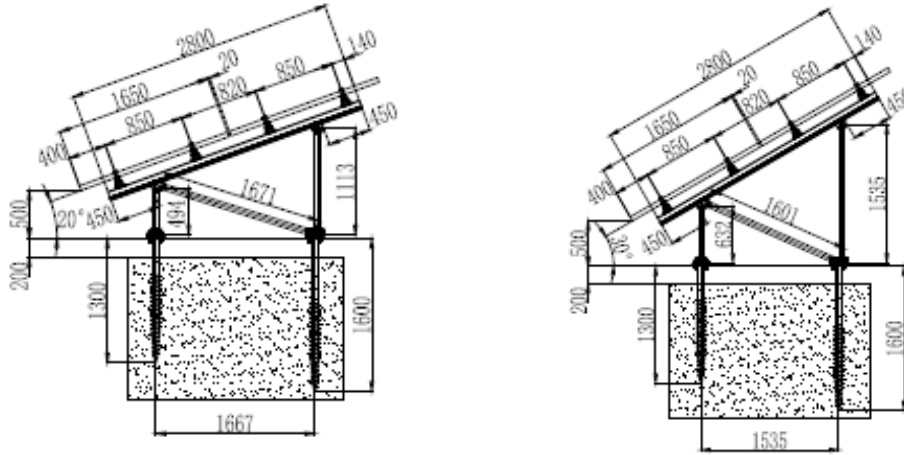

Side view drawings of support for 60 cell panels (up to 1700 x 1400mm)

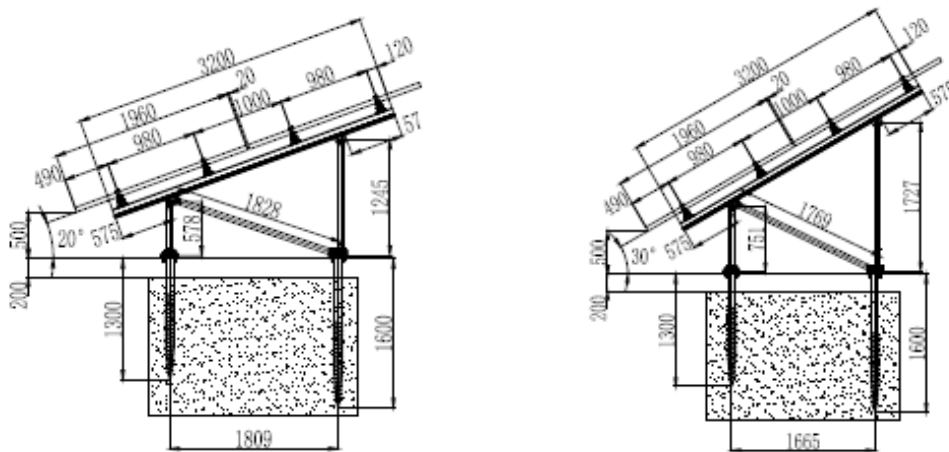

Side view drawings of support for 72 cell panels (up to 2000 x 1400mm)

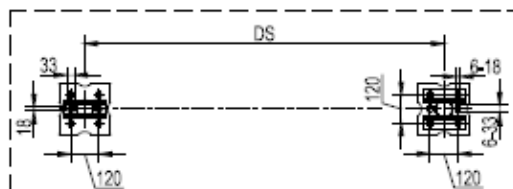

Location Plan of Anchors (DS is the distance between the front leg and rear leg)

PLEASE NOTE THE DISTANCE BETWEEN FRONT LEG AND REAR LEG COULD BE DIFFERENT FOR OTHER TILT ANGLES OR FOR OTHER GIRDER LENGTHS. PLEASE CONTACT CLENERGY FOR CONFIRMATION.

Pre-assembled Support Installation

Unfold the Pre-assembled Support

Solution 1 (For 30 degree tilt support)

Step 1:

Unfold the pre-assembled support as shown in Fig. 2;

Step 2:

Unfold the Slotted Al-Tube as shown in Fig.3;

Step 3:

Unlock the M12*100 bolts from the H Joint first and fasten the Al-Tube and H Joint lightly with M12*100 again as shown in Fig.4;

Step 4:

Rotate the L-anchor and U-anchor plates to ensure they align as shown as Fig. 5.

Note:

The bolt heads have to be kept in same direction.



Fig. 1



Fig. 2

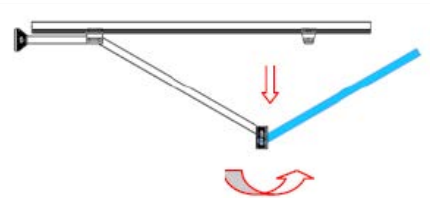

Fig. 3

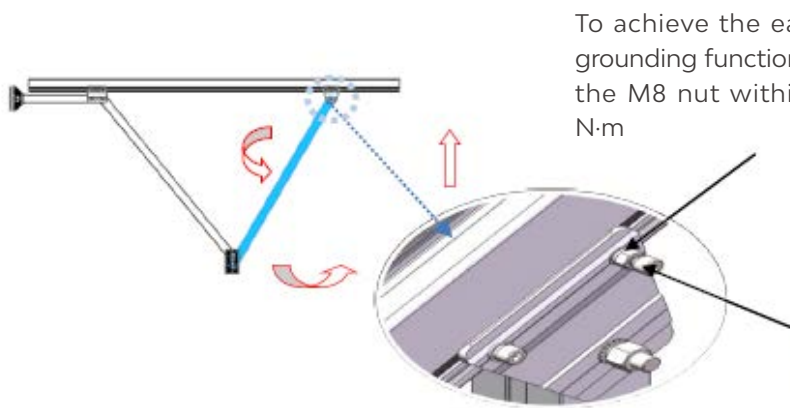

Fig. 4

To achieve the earthing/grounding function, fasten the M8 nut within 18-20 N·m

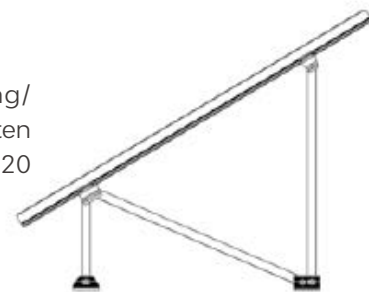

Fig. 5

To achieve the earthing/grounding function, fasten the M8*40 bolt within 13- 14 N·m

Solution 2 (For 20 degree tilt support)

Step 1:

Unfold the pre-assembled support as shown in Fig.7 and 8;



Fig. 6

Step 2:

Unlock the M12*100 bolts from H Joint first and fasten the Al-Tube and H Joint lightly with M12*100 again as shown in Fig.8;



Fig. 7

Step 3:

Rotate the L-anchor and U-anchor plates to ensure they align as shown as Fig.10.

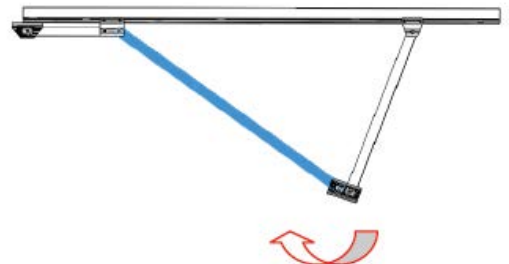

Fig. 8

Note:

The bolt heads have to be kept in same direction.

To achieve the earthing/grounding function, fasten the M8 nut within 18-20 N·m

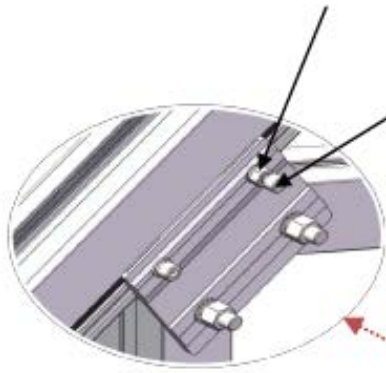

Fig. 9

To achieve the earthing/grounding function, fasten the M8 nut within 18-20 N·m

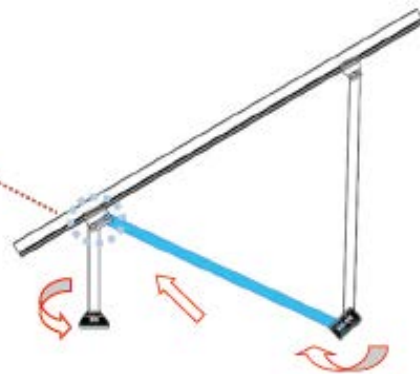
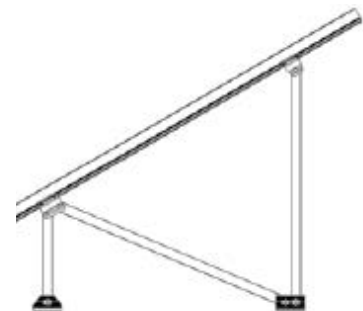

Fig. 10



Fix the Pre-assembled Support to the Concrete Footings.

Fix the Pre-assembled Support to the Concrete footings laid using the dimensions indicated by the tables in the Planning section. Use embedded M16 (Grade 5.8 Carbon Steel anchor studs or similar). Adopt the minimum anchor embedded depth according the anchors manufacturer's Manual. The up-down adjustable range of the Front/Rear leg is $\pm 20\text{mm}$. The north-south adjustable range of the Front/Rear leg is $\pm 7.5\text{mm}$.

Recommended Torque:
M16: 135~150N·m

To achieve earthing/ grounding function, fasten the M8*12 bolt within 4.5-5.5 N·m

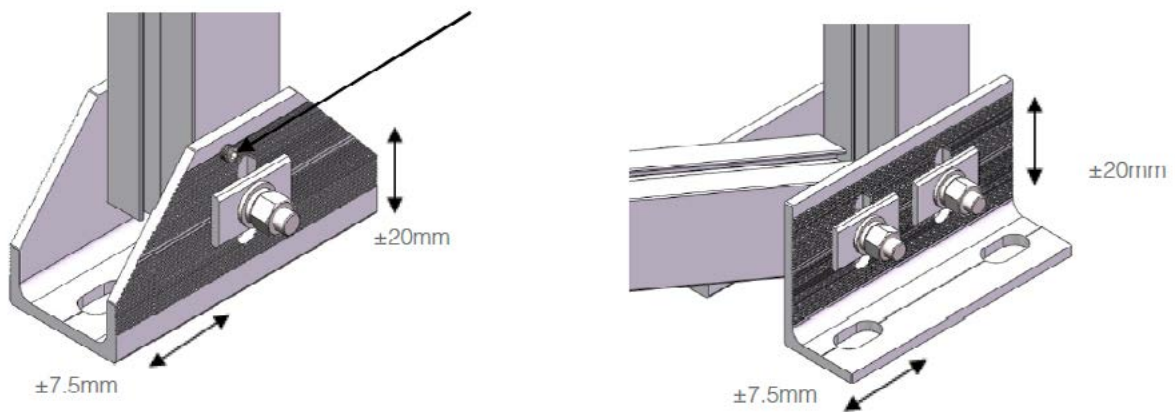

Fig. 11

Check the System and Fasten all Bolts with Recommended Torque (please refer to Page 14).

Recommended Torque:
M8 Bolt: 13N·m;
M8 Nut: 18~20N·m
M12: 40~45N·m

According to Engineering Drawing, Repeat the Above Operations to Install Other Preassembled Supports

Ensure all the Tri-Groove Beams of Pre-assembled Support are aligned and all Pre-assembled Supports are parallel to each other.
Now fasten all bolts tightly.

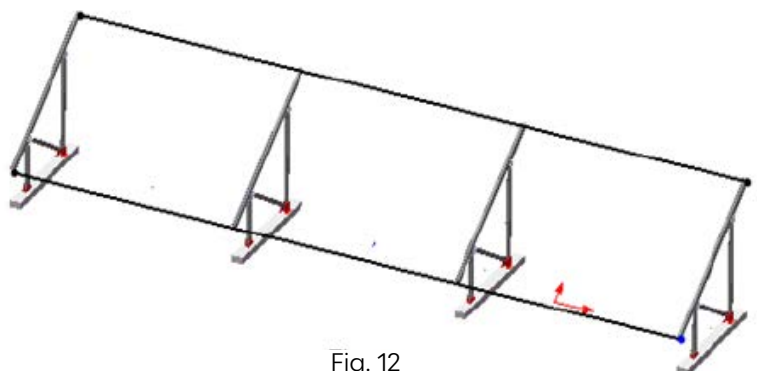

Fig. 12

T Rail Installation

Direct Installation

According to the engineering drawing, mark the locations for the Rail on the Tri-groove beam. The dimensions shown in the figure on the right is an example.

Slide the T Rail on to the Tri-Groove Beam. Apply one Rail Clamp to the T Rail on each side of Rail, and fasten lightly with the 6mm Allen Key as shown in the Figures below.

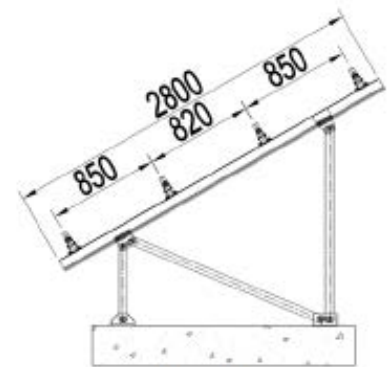

Fig. 13

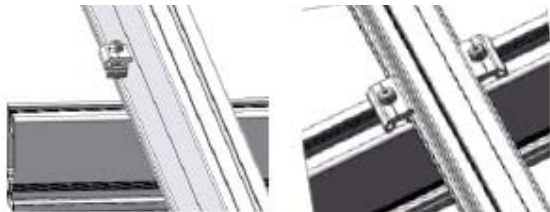

Fig. 14



Fig. 15

Note:

if the Pre-assembled Support has pre-positioned Rail Clamps for the T Rail, slide another Rail Clamp in other side of the T Rail.

If the T Rail is not long enough, connect two T Rails together using the Splice for the T-110 Rail as shown in the diagram below. Insert half of the Splice into the T Rail and fasten with two sets of Selftapping screws in each side of the T Rail, and then insert the other Splice into the T Rail and again fasten with Self-tapping screws. To prevent thermal expansion problems, the Rails shall not exceed 30m long.

Note:

Please fasten the Self-tapping screw until the rubber washer grips firmly, attaching the T Rails tightly onto the splice.

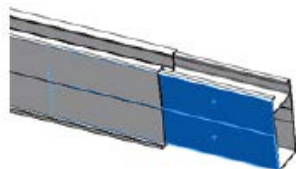

Insert half of Splice into the T Rail

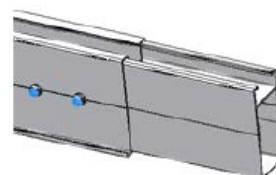

Then use two sets of Self-tapping screws in each side of the T Rail

Fig. 16



Insert half of the Splice into the T Rail

Two sets of Self-tapping screws each side of the T Rail

Fig. 16

Place the T Rails one by one in the planned position on the supports.

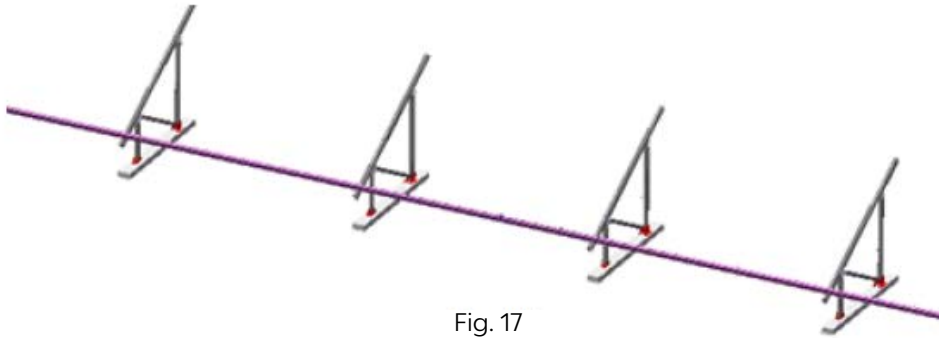

Fig. 17

Repeat the above operations and install all other T Rails. Ensure the end faces of the Rails are aligned and all Rails are at same height. Now fasten all the bolts tightly.

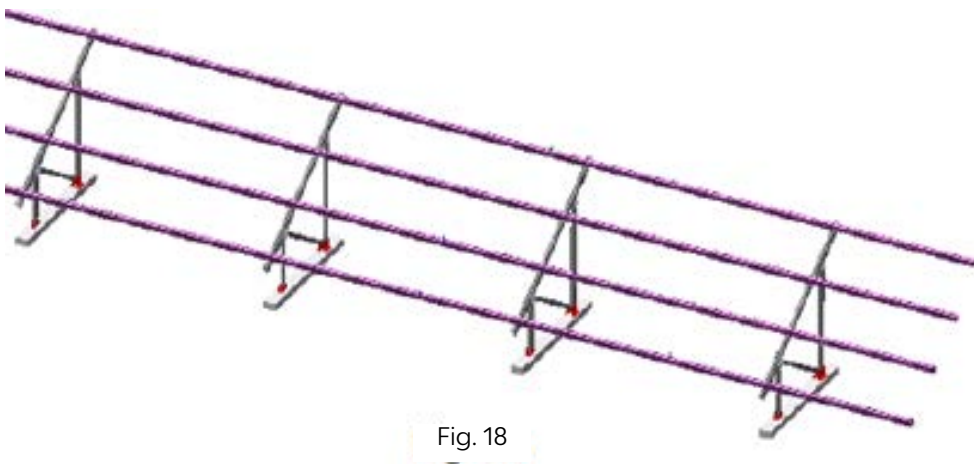

Fig. 18

East/West Adjustable Bracket Installation (optional)

Click the pre-assembled East/ West Adjustable Bracket into the Tri- Groove Beams and adjust properly as shown in Fig.19. Fasten the M8 bolt slightly with the Allen key.

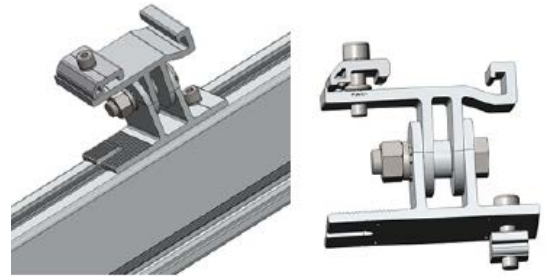

Fig. 19

Click the corrugated shim and Z Mould/bolt into the Tri-Groove Beams and move them into the opening slot hole of East/West Adjustable Bracket. After the bolt is at the end of slot hole, fasten the M8 bolts slightly as shown in Fig. 20.

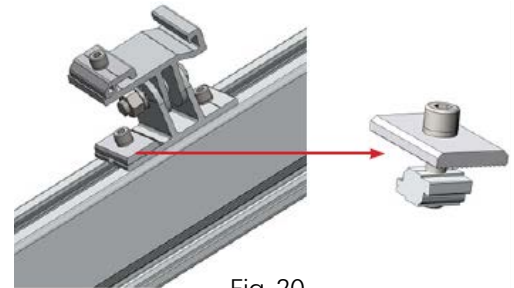

Fig. 20

Repeat above steps to install other East/West Adjustable Brackets. Adjust all brackets and make the brackets sit at the right positions.

Now fasten all M8 bolts tightly within 18~20 N·m.

Tilt the T Rail to a certain angle and slide into the groove of East/West Adjustable Brackets of the same height on the Tri-Groove Beams. Then use a 6mm Allen key (Hex) to fasten on another side via Rail Clamp for T-Rail. Fasten all the M12 bolts on the East/ West Adjustable Brackets.

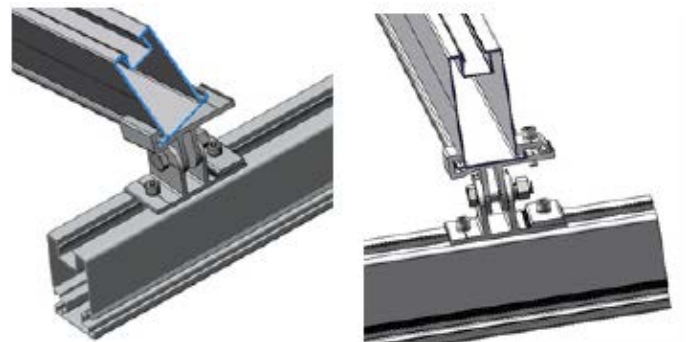

Fig. 21

Recommended Torque:

M8: 18~20 N·m

M12: 50~55 N·m

Repeat the step on P20 (Fig.16) to determine the necessary length of T-Rail prior to installation.

Repeat the above operations and install all other T Rails. Ensure the end faces of the Rails are aligned and all Rails are at same height. Now fasten all the bolts tightly.

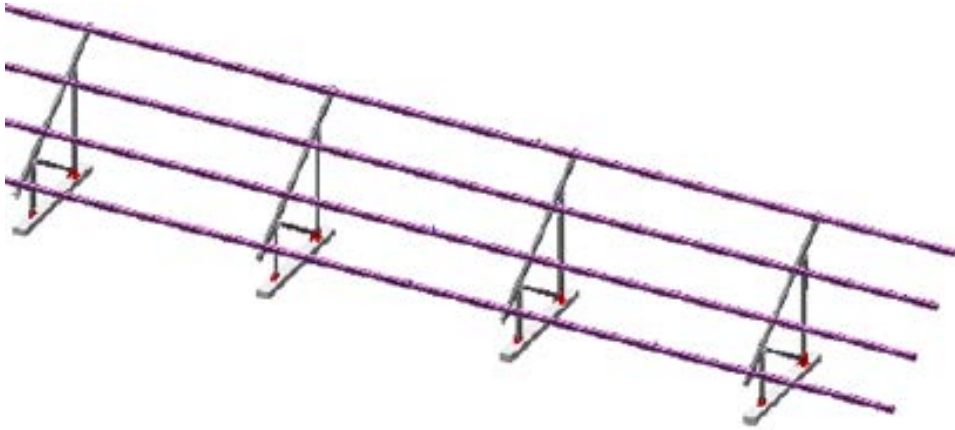
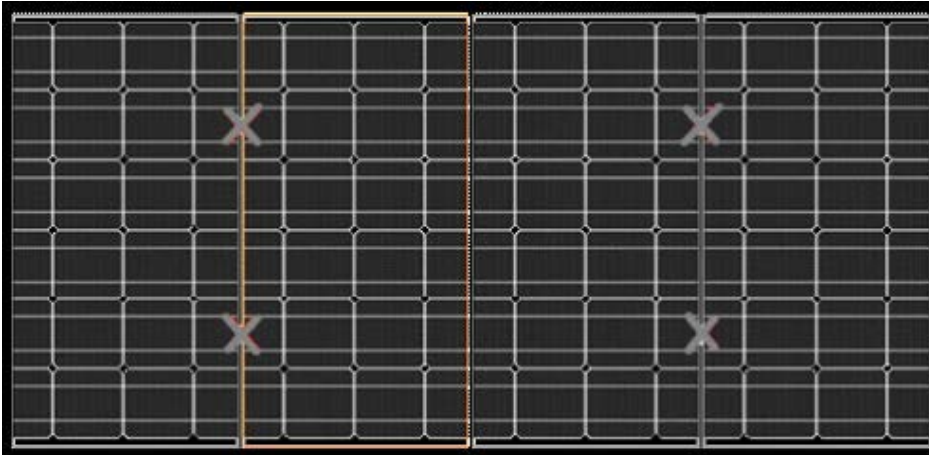

Fig. 22

PV Module Installation

Deployment of Grounding Clip

1) When there is an even number of PV Module in each row



Install the Grounding clips at the positions marked X in the figure shown. Then the number of Grounding clips = number of PV Modules. Eg: 4 Grounding clips in the figure shown.

2) When there is an odd number of PV Module in each row

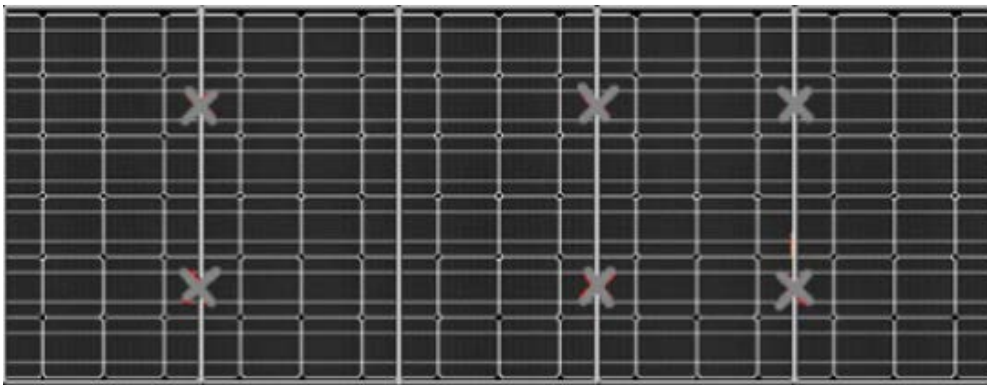

Install the Grounding clips at the positions marked X in the figure shown. Then the number of Grounding clips = number of PV Modules +1. Eg: 6 Grounding clips in the figure shown.

Key point:

When replacing a defective single PV Module, it is required to replace the Grounding Clip under the PV Module, as they are intended for single use only.

Place the PV Modules on the Rails, and fix them with End Clamps and Inter Clamps or Universal Clamps, then fasten them with the Allen key. Please choose either Solution 1 or 2 below, according to your project.

Solution 1 (Apply End Clamps and Inter Clamps)

Step 1:

Place the first PV Module on the T Rails according to your plan and apply the End Clamps to fix it in place. Then fasten lightly with the Allen Key as shown in Fig. 23.

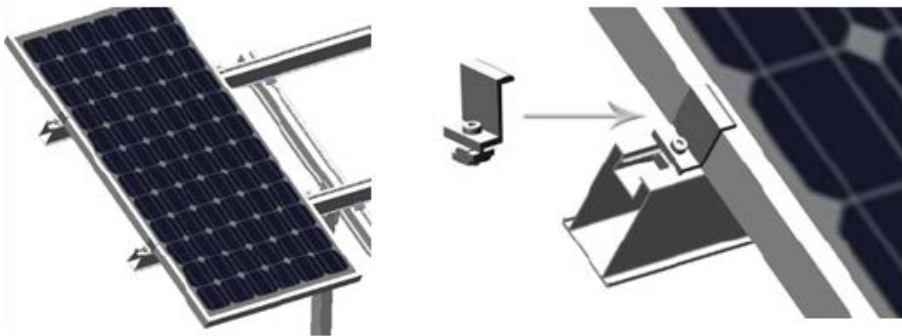

Fig. 23

Step 2:

Slightly lift the PV Module and slide the Inter Clamps and Grounding Clips into position. The teeth on Grounding Clip will be automatically aligned when the Inter Clamp is properly installed as shown in Fig. 24.

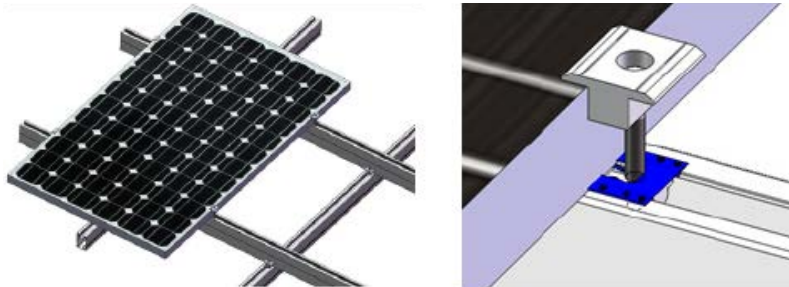

Fig. 24

Step 3:

Place the next framed PV Module into the other side of Inter Clamp and Grounding Clip as shown in Fig. 25.

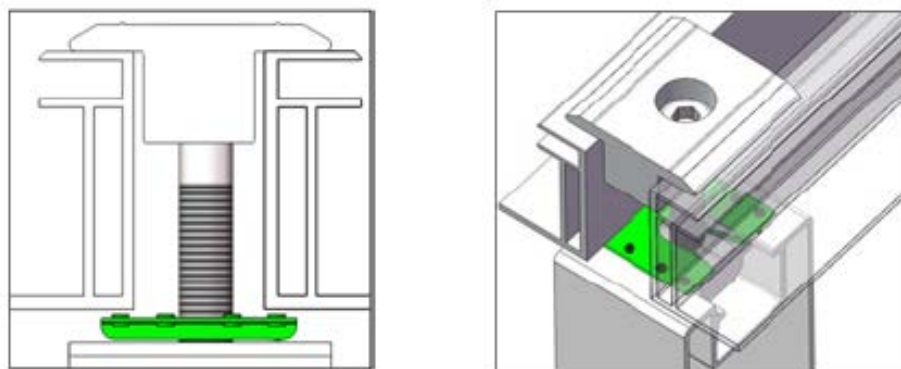

Fig. 25

Important Notes:

To fix the Grounding Clip properly, ensure the frames of the PV Modules are now firmly pressed against the Inter Clamp and Grounding Clip and visually check that Grounding Clips are positioned properly. (Grounding Clips are intended for SINGLE USE ONLY!) Only fasten the bolts down when you are sure the PV modules are in the correct position and lightly tighten the bolts at this stage to keep the PV Modules in place.

Step 4:

When using End and Inter clamps, maintain an 18mm vertical and horizontal gap between the two adjacent rows of PV Modules. You can use two Inter Clamps as separation between two PV Modules to achieve this and remove them after the installation is completed as shown in Fig. 26.

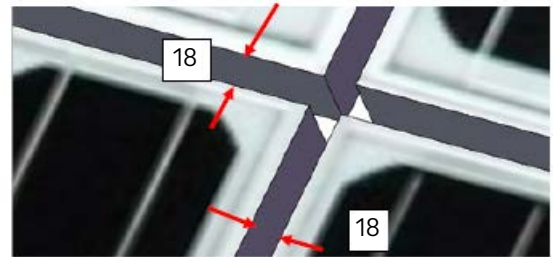

Fig. 26

Step 5:

Repeat the above steps to install all PV Modules. Fasten all the End and Inter Clamps tightly with 18~20N.m until all the PV Modules are correctly installed.

Solution 2 (Apply Universal Clamps)

Step 1:

Twisting the head of the Universal Clamp changes the functionality from end to inter clamp as shown in Fig. 27.

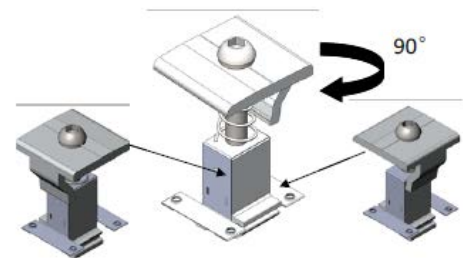

Fig. 27

Note:

Please ensure the Universal Clamp C-U/30/46 or Universal Clamp with Grounding clip C-U/30/46-G is positioned correctly according to 5.3.1: Deployment of Grounding clip.

Step 2:

Incline the Universal Clamp to place the channel on its lower part against the lower channel of the T Rail. Then press the Universal Clamp down towards the other side of the T Rail to engage the channel on its upper part against the upper channel of T Rail as shown in Fig. 28.

Note:

Before installation, make sure there will be enough clearance between the screw and module of Universal Clamp as shown in Fig. 28 (next page).

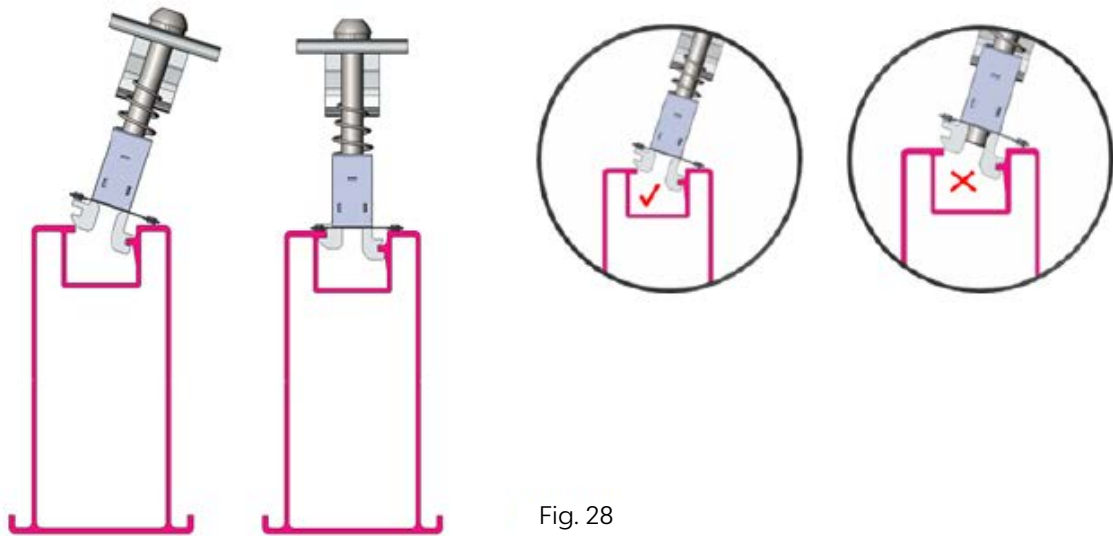

Fig. 28

Step 3:

Place the first PV Module on the T Rails and position the Universal Clamp as an End Clamp to fix it and then fasten lightly with Allen Key. Make sure the frame of the PV Module is fully in contact with the Universal Clamp as shown in Fig.29. Visually check the Universal Clamp and PV module are correctly installed.

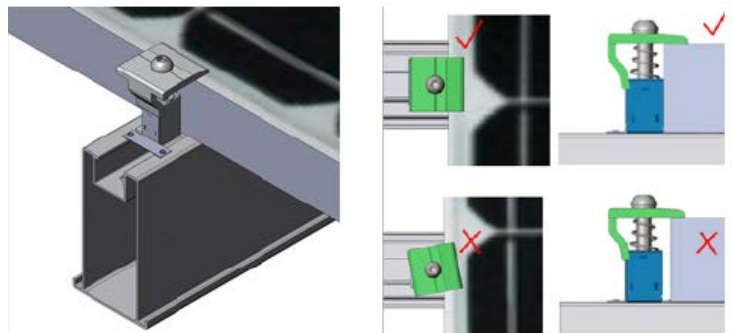

Fig. 29

Step 4:

When using as Inter Clamp, click the Universal Clamp into the channel of T Rail and then slightly lift the framed PV Module to make sure the Grounding Clip of Universal Clamp is fully covered as shown in Fig. 30.

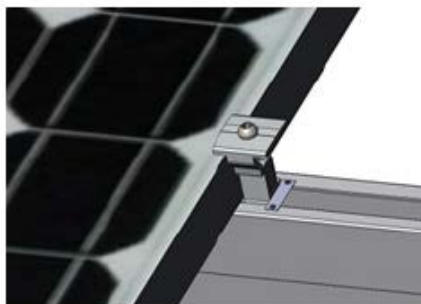

Fig. 30

Step 5:

Place the next framed PV Module into the other side of Universal Clamp. Make sure the Grounding Clip of the Universal Clamp will be fully covered and ensure the frame of PV Module is closely in contact with Universal Clamp as shown in Fig. 31. Note the 20mm gap when using Universal Clamps.

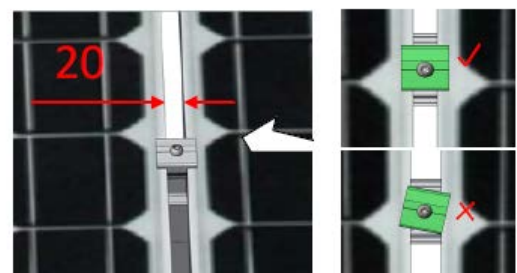

Fig. 31

Step 6:

Repeat the above steps to install all PV Modules. Visually check the Universal Clamps and PV modules are properly positioned and then tighten all Clamps.

The recommend torque for Universal Clamps that are used as End Clamps is 13~14N·m.

The recommend torque for Universal Clamps that are used as Inter Clamps is 18~20N·m.

End of Solutions

Apply one pre-assembled Grounding Lug per T Rail. Click the Grounding Lug into the channel of the T Rail and insert the Copper Wire. (the maximum size is 6AWG or similar) Then fasten the bolt M6*10 with 10N·m and fasten the bolt M8*25 with 13.5N·m as shown in the Fig.32.



Fig. 32

Now the installation is completed as shown in Fig.33. Please recheck all Bolts and fasten them tightly according to the recommended torque. The PV Modules should be aligned correctly with 18mm gaps when using End and Inter Clamps and 20mm gaps when using Universal Clamps.



Fig. 33

Ground Screw Installation (Alternative to a Concrete Base and dependent on the system design)

Before the installation, please prepare the necessary installation tools & products, and ensure that the hydraulic pile driver can work normally at the installation site. Read the relevant engineering documents to get the project layout information such as piling depth, column span, etc. If you have any questions, please contact and consult Clenergy customer service.



Fig. 34

According to the installation planning, use Total Station (or any instrument of similar functions) to mark out the piling position of each Ground Screw. Check the marked positions before piling, to ensure accuracy.

Minimum piling depth of ground screws is determined by the corresponding engineering letter. Front leg and rear leg of Solar Terrace III-A are connected with 1300 mm and 1600 mm long ground screws, respectively.



Fig. 35

Ensure all Ground Screws are on the same level and aligned as per the diagram below.

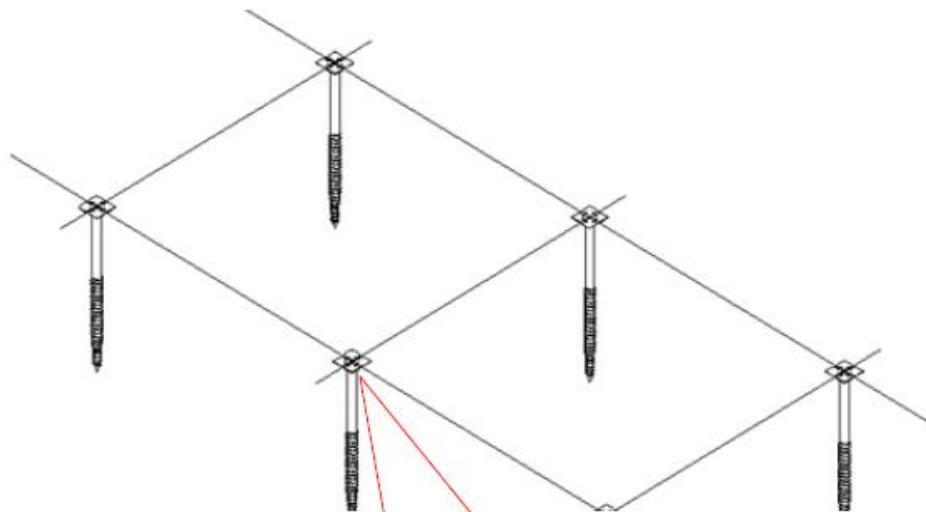

Fig. 36

The maximum allowable connection deviation of the Ground Screw to the Support should be within the range of adjustments shown in Fig. 37 below.

Follow Solution 1 or Solution 2 (on page 17 and 18 depending on either a 30 or 20 degree tilt support) to unfold and construct the pre-assembled support.

Connect the Pre-assembled Support to the Ground Screws by using Hex Bolts M16*50 with Nuts and Washers. A plain washer is at bolt head side and two washers are at nut side. The spring washer needs to be placed next to nut. See Fig. 37.

Recommended Torque:
M16: 135~150N·m

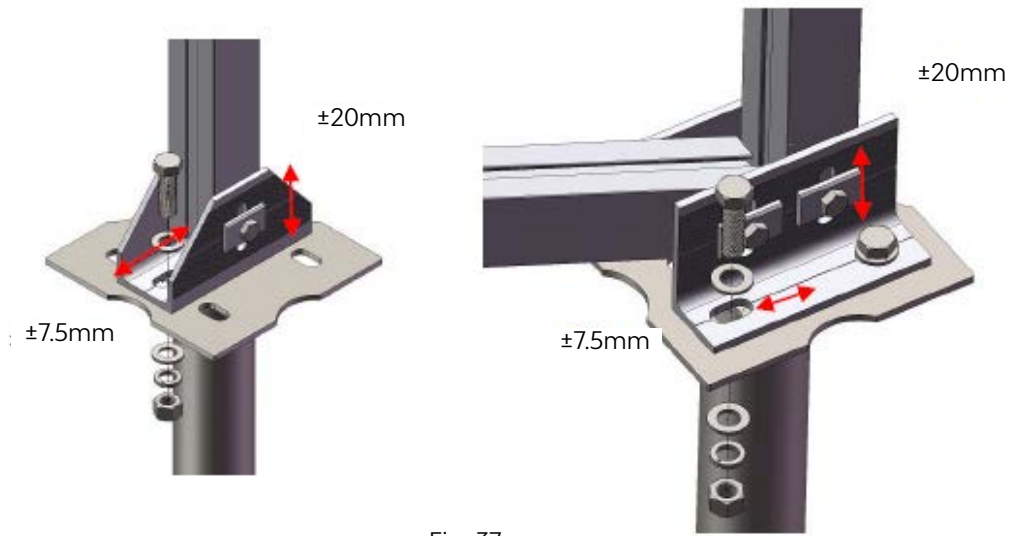

Fig. 37

Ground screw connection plate enables the connection of either U or L anchors, which also allows some adjustment to the support structure as shown in Fig. 37 above.

Certification



Gamcorp (Melbourne) Pty Ltd A.C.N 141 076 904 A.B.N 73 015 060 240
www.gamcorp.com.au melbourne@gamcorp.com.au
 Tel: 03 9543 2211

Our Ref: **5510-1** / BG-AdA-LvS-NK
 4 May 2022

Clenergy Australia
 1/10 Duerdin Street
 Clayton, VIC 3168

Array Frame Engineering Certificate

RE: Solar Terrace III-A with Panels 1700 mm high

Gamcorp (Melbourne) Pty Ltd, being Structural Engineers within the meaning of Australian and NZ Building Regulations, have carried out a structural design check of the PV-ezRack SolarTerrace III-A with panels 1700mm high, within Australia and New Zealand. The design check has been based on the information in the *PV-ezRack SolarTerrace III-A Planning and Installation Guide* and schematic drawings of the system components, provided by Clenergy Australia.

Component Description	Part Number
T-Rail 110	ER-R-T110/XX
PV-ezRack SolarTerrace III-A, Single Support (Pre-assembled) 20°, with 2800 mm Girder	ER-S-STIIIA/S20
PV-ezRack SolarTerrace III-A, Single Support (Pre-assembled) 30°, with 2800 mm Girder	ER-S-STIIIA/S30
Splice for T-Rail 110	ER-SP-T110
PV-ezRack Inter Clamp	ER-IC-STXX
PV-ezRack End Clamp	ER-EC-STXX
PV-ezRack Universal Clamp for Frame Height 30-46mm with Grounding Clip	C-U/30/46-G
PV-ezRack Universal Clamp for Frame Height 30-46mm	C-U/30/46
PV-ezRack T-Rail Clamp with Grounding	ER-RC-T/G
East/West Adjustable - Bracket for T-Rail 110	BR-R110/EW, BR-R110/EW/G

We find the SolarTerrace III-A to be structurally sufficient for Australian and New Zealand use, based on the following conditions:

- Wind Loads to AS/NZS1170.2:2011 (R2016);
 - Wind Terrain Category 2;
 - Wind average recurrence interval of 100 years (ultimate);
 - Wind region A, B, C & D;
 - Ms=1, Md=1, Mt=1;
- Soils classification and properties to AS/NZS 4676-2000 and AS4678-2002;
- Solar Panel size up to **1.4** m wide x **1.7** m high (max) in portrait orientation, mass approx **15 kg/m²**;
- Maximum support(frame) spacing and footing options: refer following pages.
- For ground screws option see Gamcorp letter 6292

ISO 9001:2015 Registered Firm
 Certificate No: AU1222



Gamcorp (Melbourne) Pty Ltd A.C.N 141 076 904 A.B.N 73 015 060 240
www.gamcorp.com.au melbourne@gamcorp.com.au
 Tel: 03 9543 2211

Maximum Support Frame Spacing and Footing Options

Wind region	A								B								C				D			
Regional wind speed (VR, m/s)	41								48								39				73			
Panel Tilt angle	20°				30°				20°				30				20°				20°			
	Front Leg	Rear Leg	Cl(mm)	h(mm)	Front Leg	Rear Leg	Cl(mm)	h(mm)	Front Leg	Rear Leg	Cl(mm)	h(mm)	Front Leg	Rear Leg	Cl(mm)	h(mm)	Front Leg	Rear Leg	Cl(mm)	h(mm)				
Maximum spacing (S, m)	3.75				3.25				3.65				3.15				3.20				2.7 (2.45*)			
Uplift (kN)	1.8	7.2	0.0	12.6	2.9	9.9	0.0	17.0	4.4	13.3	6.1	17.5												
Down Force (kN)	6.4	4.1	5.4	6.5	7.9	5.2	6.7	8.4	9.8	6.5	12.1	8.1												
Total horizontal force at leg base (kN)	4.0				7.7				5.3				10.2				7.0				9.1			
Footing Type	Concrete Footing Options								Concrete Footing Options								Concrete Footing Options				Concrete Footing Options			
Wind region	A								B								C				D			
Continuous Paving Slab, Length x Thickness (L x T) - m	3.30 x 0.14		500	0	3.4 x 0.14		500	0	3.30 x 0.14		500	0	3.40 x 0.14		500	0	3.30 x 0.14		500	0	3.40 x 0.14		500	0
Adapt req	N8@125 both ways (bw) or 3-81								N8@125 both ways (bw) or 3-81								N8@125 both ways (bw) or 3-81				N8@125 both ways (bw) or 3-81			
Continuous Strip Footing, Width x Depth (W x D) - m	0.30x0.40	0.35x0.40	700	200	0.35 x 0.50	0.45 x 0.50	500	0	0.35 x 0.45	0.40 x 0.45	700	200	0.50 x 0.58	0.58 x 0.58	700	200	0.50 x 0.50	0.50 x 0.50	700	200	0.55 x 0.65	0.60 x 0.65	600	100
Adapt req	3-81								3-81								3-81				3-81			
Individual Pier Footing, Pier Leg Length (HWD) x Depth (D x C x H)	0.45 x 0.45	0.50 x 0.50 x 0.55	700	200	0.85 x 0.85 x 0.9	0.90 x 0.90 x 0.9	800	300	0.5x0.5 x 0.6	0.6 x 0.6 x 0.6	800	300	0.9 x 0.9 x 0.9	1.0 x 1.0 x 0.9	900	400	0.60x0.60x0.65	0.65 x 0.65 x 0.65	700	200	0.7 x 0.7 x 0.75	0.7 x 0.7 x 0.75	700	200
Adapt req	3-81								3-81								3-81				3-81			
Reverse Strip Footing, Length x Width x Depth (L x W x D)	2.20 x 0.60 x 0.60		900	400	2.50 x 0.70 x 0.70		800	300	2.35 x 0.65 x 0.65		600	100	2.75 x 0.75 x 0.75		600	100	2.40 x 0.75 x 0.75		600	100	2.7 x 0.8 x 0.8		600	100
Adapt req	3-81								3-81								3-81				3-81			

Note(*): when using east west adaptor

ISO 9001:2015 Registered Firm
 Certificate No: AU1222



Gamcorp (Melbourne) Pty Ltd A.C.N 141 076 904 A.B.N 73 015 060 240
www.gamcorp.com.au melbourne@gamcorp.com.au
Tel: 03 9543 2211

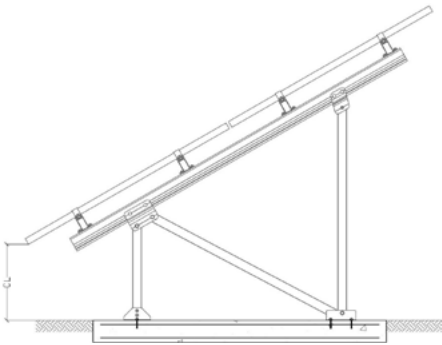

Continuous Paving Slab

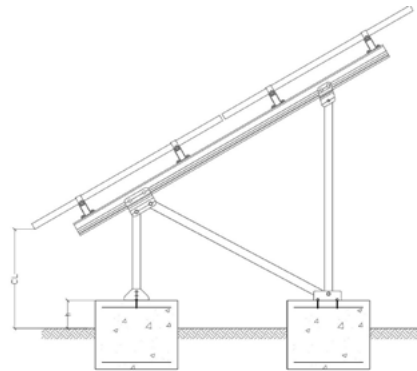

Continuous Strip Footing



Gamcorp (Melbourne) Pty Ltd A.C.N 141 076 904 A.B.N 73 015 060 240
www.gamcorp.com.au melbourne@gamcorp.com.au
 Tel: 03 9543 2211

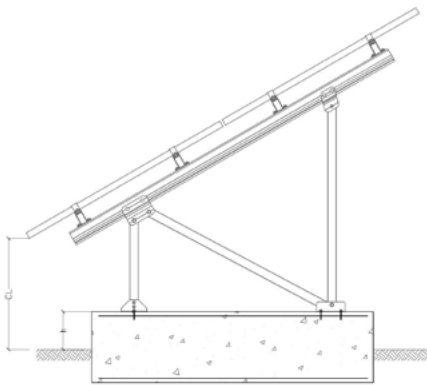

Transverse Strip Footing

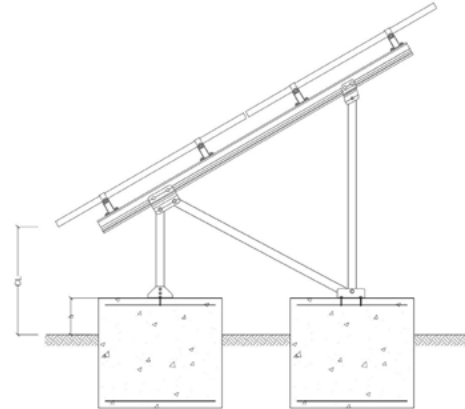

Individual Pad footing



Gamcorp (Melbourne) Pty Ltd A.C.N 141 076 904 A.B.N 73 015 060 240
www.gamcorp.com.au melbourne@gamcorp.com.au
Tel: 03 9543 2211

Notes:

1. The footing examples shown, recommended for 'Firm' soils with allowable end bearing capacity of 100 kPa minimum (damp clays, sandy clays, damp sands). Contact Gamcorp for site specific conditions (to find out whether more cost effective solution is possible).
2. Concrete grade: N25 minimum, cover: 50mm (Contact Gamcorp to find out whether more cost effective solution is possible, based on site specific conditions).
3. For the fixing of STIII-A to the concrete footing we recommend using M16 (Grade 5.8 Carbon Steel anchor studs or similar). Adopt minimum anchor embedment depth according the anchors manufacturer's manual. Clenergy STIII-A has 6 anchors per frame, 2 at front and 4 at rear.
4. Other footing options are possible – contact Gamcorp.

Construction is to be carried out strictly on accordance with the instruction manual. This work was designed by **Acha De Alwis** in accordance with the provisions of Australian Building Regulations and in accordance with sound, widely accepted engineering principles. Should you need to clarify anything please contact the designer. This certification is valid till **August 31, 2022**, unless any of the relevant Australian Standards becomes updated before the due date.

Yours faithfully,
Gamcorp (Melbourne) Pty Ltd

L. van Spaandonk
Principal Engineer
FIEAust CPEng NER

Attachments

- Frames pictures by Clenergy
- Footing drawings by Gamcorp (S01-S04)

ISO 9001:2015 Registered Firm
Certificate No: AU1222



Gamcorp (Melbourne) Pty Ltd A.C.N 141 076 904 A.B.N 73 015 060 240
www.gamcorp.com.au melbourne@gamcorp.com.au
 Tel: 03 9543 2211

Part Number: ER-S-STIIIA/S20

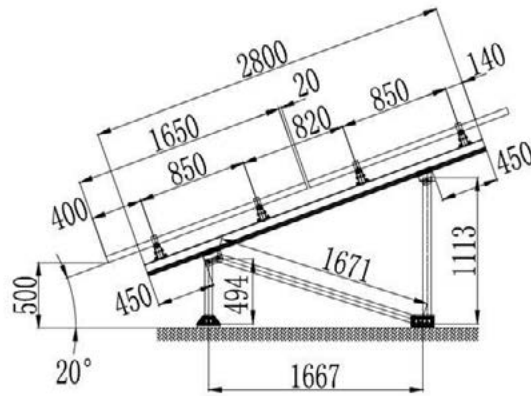

Part Number: ER-S-STIIIA/S30

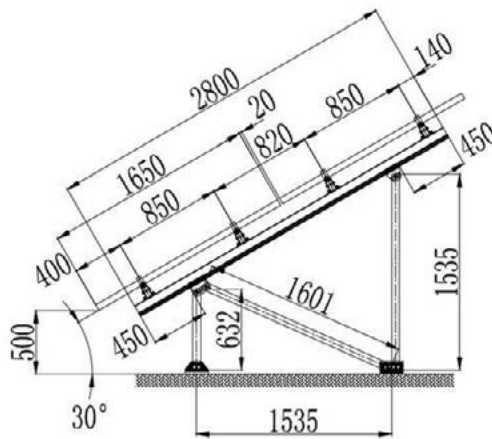

ISO 9001:2015 Registered Firm
 Certificate No: AU1222



Gamcorp (Melbourne) Pty Ltd A.C.N 141 076 904 A.B.N 73 015 060 240
www.gamcorp.com.au melbourne@gamcorp.com.au
 Tel: 03 9543 2211

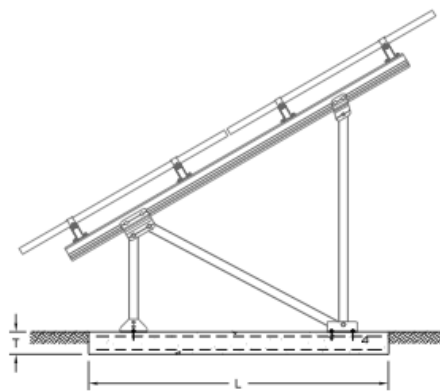

SECTION

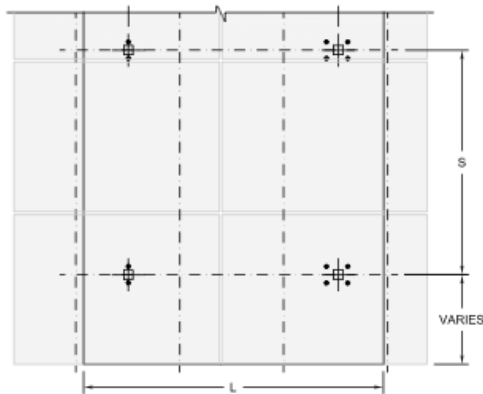

PLAN

S01. Continuous Paving Slab

ISO 9001:2015 Registered Firm
 Certificate No: AU1222



Gamcorp (Melbourne) Pty Ltd A.C.N 141 076 904 A.B.N 73 015 060 240
www.gamcorp.com.au melbourne@gamcorp.com.au
 Tel: 03 9543 2211

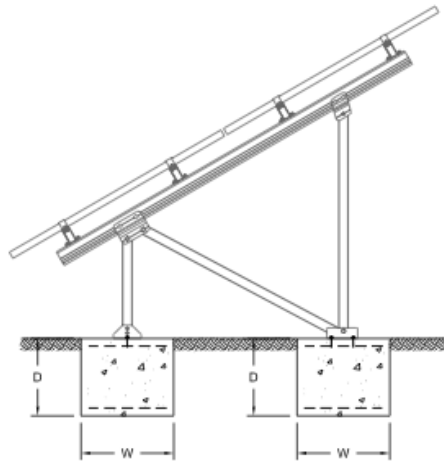

SECTION

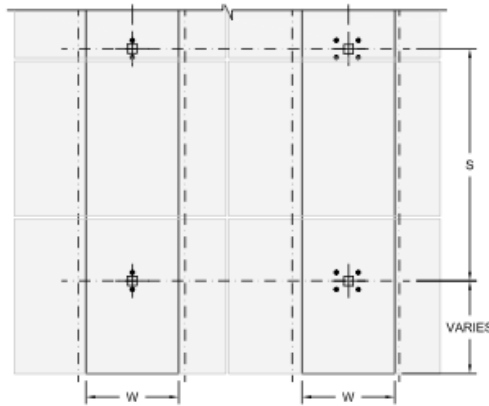

PLAN

S02. Continuous Strip Footing

ISO 9001:2015 Registered Firm
 Certificate No: AU1222

5510-1 - Compliance Letter STIII-A - 60 Cells Panels - 20220504

Page 8 of 10



Gamcorp (Melbourne) Pty Ltd A.C.N 141 076 904 A.B.N 73 015 060 240
www.gamcorp.com.au melbourne@gamcorp.com.au
 Tel: 03 9543 2211

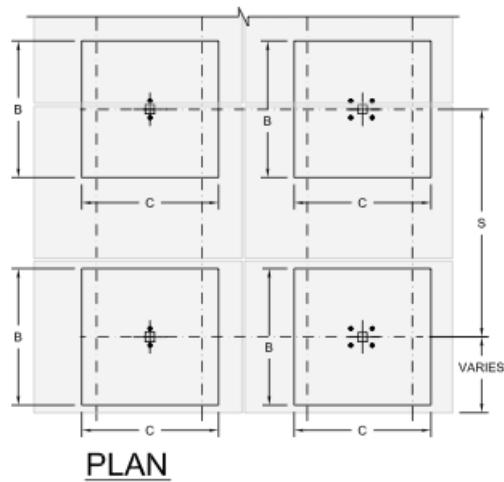
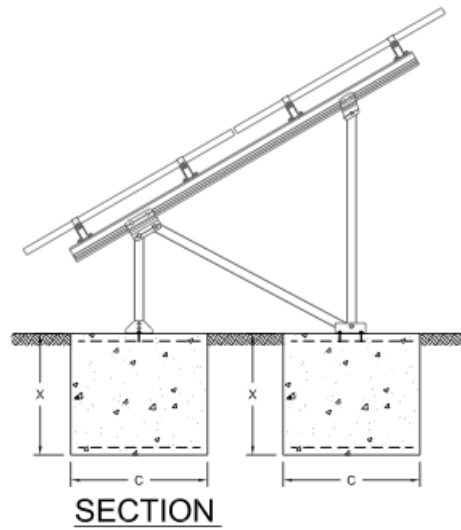

S03. Individual Pad footing per leg

ISO 9001:2015 Registered Firm
 Certificate No: AU1222



Gamcorp (Melbourne) Pty Ltd A.C.N 141 076 904 A.B.N 73 015 060 240
www.gamcorp.com.au melbourne@gamcorp.com.au
 Tel: 03 9543 2211

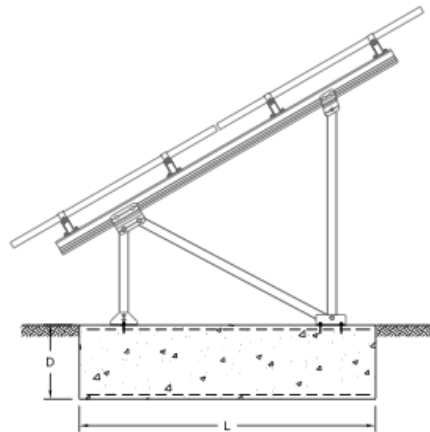

SECTION

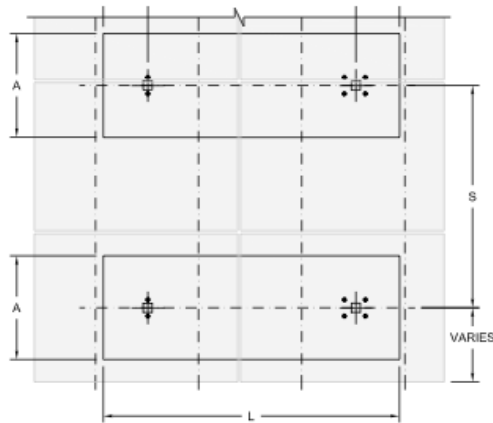

PLAN

S04. Transverse Strip Footing

ISO 9001:2015 Registered Firm
 Certificate No: AU1222

5510-1 - Compliance Letter STIII-A - 60 Cells Panels - 20220504

Page 10 of 10



Gamcorp (Melbourne) Pty Ltd A.C.N 141 076 904 A.B.N 73 015 060 240
www.gamcorp.com.au melbourne@gamcorp.com.au
 Tel: 03 9543 2211

Our Ref: **5510-2/** BG-AdA-LvS-NK
 4 May 2022

Clenergy Australia
 1/10 Duerdin Street
 Clayton, VIC 3168

Array Frame Engineering Certificate

RE: SolarTerrace III-A with panels 2000 mm high

Gamcorp (Melbourne) Pty Ltd, being Structural Engineers within the meaning of Australian and NZ Building Regulations, have carried out a structural design check of the PV-ezRack SolarTerrace III-A with panels 2000mm high within Australia and New Zealand. The design check has been based on the information in the *PV-ezRack SolarTerrace III-A Planning and Installation Guide* and schematic drawings of the system components, provided by Clenergy Australia.

Component Description	Part Number
T-Rail 110	ER-R-T110/XX
PV-ezRack SolarTerrace III-A, Single Support (Pre-assembled) 20°, with 3200 mm Girder	ER-S-STIIIA/D20
PV-ezRack SolarTerrace III-A, Single Support (Pre-assembled) 30°, with 3200 mm Girder	ER-S-STIIIA/D30
Splice for T-Rail 110	ER-SP-T110
PV-ezRack Inter Clamp	ER-IC-STXX
PV-ezRack End Clamp	ER-EC-STXX
PV-ezRack Universal Clamp for Frame Height 30-46mm with Grounding Clip	C-U/30/46-G
PV-ezRack Universal Clamp for Frame Height 30-46mm	C-U/30/46
PV-ezRack T-Rail Clamp with Grounding	ER-RC-T/G
East/West Adjustable - Bracket for T-Rail 110	BR-R110/EW, BR-R110/EW/G

We find the SolarTerrace III-A to be structurally sufficient for Australian and New Zealand use, based on the following conditions:

- Wind Loads to AS/NZS1170.2:2011 (R2016);
 - Wind Terrain Category 2;
 - Wind average recurrence interval of 100 years (ultimate);
 - Wind region A, B, C & D;
 - Ms=1, Md=1, Mt=1;
- Soils classification and properties to AS/NZS 4676-2000 and AS4678-2002;
- Solar Panel size up to **1.4m** wide x **2.0m** high (max) in portrait orientation, mass approx **15kg/m²**;
- Maximum support(frame) spacing and footing options at the edge zone: refer following pages.
- For ground screws option see Gamcorp letter 6292.

ISO 9001:2015 Registered Firm
 Certificate No: AU1222



Gamcorp (Melbourne) Pty Ltd A.C.N 141 076 904 A.B.N 73 015 060 240
www.gamcorp.com.au melbourne@gamcorp.com.au
 Tel: 03 9543 2211

Maximum Support Frame Spacing and Footing Options

Wind region	A								B								C				D											
Regional wind speed (V _R , m/s)	41								48								59				73											
Panel Tilt angle	20°				30°				20°				30°				20°				30°											
Maximum spacing (S, m)	Front Leg		Rear Leg		Front Leg		Rear Leg		Front Leg		Rear Leg		Front Leg		Rear Leg		Front Leg		Rear Leg		Front Leg		Rear Leg									
	3.60	3.7	3.10	3.0	3.50	3.5	15.0	2.95	2.9	22.3	3.00	3.0	20.3	2.00 (1.90*)	1.9	21.5	2.00 (1.90*)	1.9	21.5	2.00 (1.90*)	1.9	21.5	2.00 (1.90*)	1.9	21.5							
Uplift (kN)	0.1	30.7	0.1	36.0	0.5	15.0	0.9	22.3	0.0	22.3	1.1	20.3	1.9	21.5	1.9	21.5	1.9	21.5	1.9	21.5	1.9	21.5	1.9	21.5	1.9	21.5						
Down Force (kN)	4.2	5.8	5.0	8.4	7.5	8.1	6.8	11.5	6.8	11.5	9.1	10.2	8.8	10.4	8.8	10.4	8.8	10.4	8.8	10.4	8.8	10.4	8.8	10.4	8.8	10.4						
Total horizontal force at leg base (kN)	4.5				8.6				6.0				11.2				7.7				7.9											
Footing Type	Concrete Footing Options								Concrete Footing Options								Concrete Footing Options				Concrete Footing Options											
Wind region	A				B				C				D																			
Continuous Paving Slab, Length x Thickness (L x T) - m	2.30 x 0.15		500		0		2.3 x 0.20		500		0		2.30 x 0.20		500		0		2.40 x 0.25		500		0		2.65 x 0.30		500		0			
Adopt reo	N16@125 both ways (bw) or SL-81								N16@125 both ways (bw) or SL-81								N16@125 both ways (bw) or SL-81				N16@125 both ways (bw) or SL-81											
Continuous Strip Footing, Width x Depth (W x D) - m	0.30x 0.40		0.35x 0.40		700		200		0.35 x 0.55		0.55 x 0.55		700		200		0.35 x 0.45		0.45 x 0.45		700		200		0.55 x 0.65		0.65 x 0.65		700		200	
Adopt reo	SL-81								SL-81								SL-81				SL-81											
Individual Pad footing per leg, Length x Width x Depth (L x W x D)	0.50 x 0.50 x 0.60		0.70 x 0.70 x 0.60		700		200		0.85 x 0.85 x 0.9		0.95 x 0.95 x 0.9		900		400		0.55x 0.55 x 0.75		0.75 x 0.75 x 0.75		800		300		0.95 x 0.95 x 0.9		1.05 x 1.05 x 0.9		900		400	
Adopt reo	SL-81								SL-81								SL-81				SL-81											
Transverse Strip Footing, Length x Width x Depth (L x W x D)	2.30 x 0.75 x 0.60		600		100		2.50 x 0.80 x 0.80		700		200		2.50 x 0.75 x 0.70		600		100		2.85 x 0.85 x 0.80		600		100		2.70 x 0.85 x 0.80		900		400			
Adopt reo	SL-81								SL-81								SL-81				SL-81											

Note(*): when using east west adaptor

ISO 9001:2015 Registered Firm
 Certificate No: AU1222



Gamcorp (Melbourne) Pty Ltd A.C.N 141 076 904 A.B.N 73 015 060 240
www.gamcorp.com.au melbourne@gamcorp.com.au
Tel: 03 9543 2211

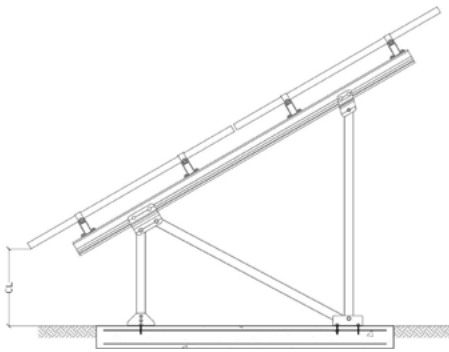

Continuous Paving Slab

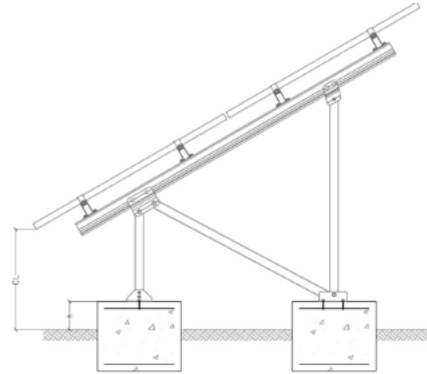

Continuous Strip Footing



Gamcorp (Melbourne) Pty Ltd A.C.N 141 076 904 A.B.N 73 015 060 240
www.gamcorp.com.au melbourne@gamcorp.com.au
 Tel: 03 9543 2211

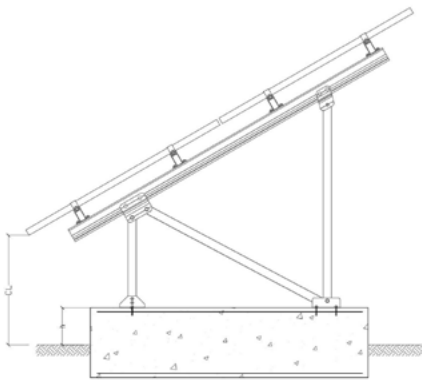

Transverse Strip Footing

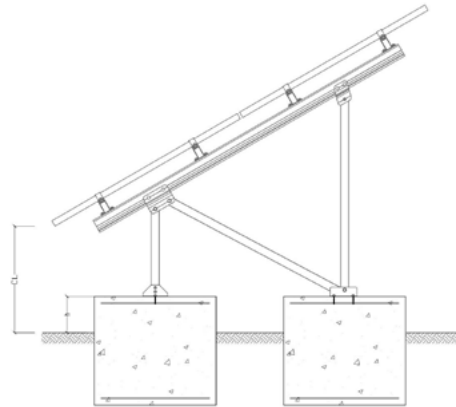

Individual Pad footing

5510-2 - Compliance Letter STIII-A - 72 Cells Panels - 20220504

ISO 9001:2015 Registered Firm
 Certificate No: AU1222

Page 4 of 10



Gamcorp (Melbourne) Pty Ltd A.C.N 141 076 904 A.B.N 73 015 060 240
www.gamcorp.com.au melbourne@gamcorp.com.au
Tel: 03 9543 2211

Notes:

1. The footing examples shown, recommended for 'Firm' soils with allowable end bearing capacity of 100 kPa minimum (damp clays, sandy clays, damp sands). Contact Gamcorp for site specific conditions (to find out whether more cost effective solution is possible).
2. Concrete grade: N25 minimum, cover: 50mm (Contact Gamcorp to find out whether more cost effective solution is possible, based on site specific conditions).
3. For the fixing of STIII-A to the concrete footing we recommend using M16 (Grade 5.8 Carbon Steel anchor studs or similar). Adopt minimum anchor embedment depth according the anchors manufacturer's manual. Clenergy STIII-A has 6 anchors per frame, 2 at front and 4 at rear.
4. Other footing options are possible – contact Gamcorp.

Construction is to be carried out strictly on accordance with the instruction manual. This work was designed by **Acha De Alwis** in accordance with the provisions of Australian Building Regulations and in accordance with sound, widely accepted engineering principles. Should you need to clarify anything please contact the designer. This certification is valid till **August 31, 2022**, unless any of the relevant Australian Standards becomes updated before the due date.

Yours faithfully,
Gamcorp (Melbourne) Pty Ltd



L. van Spaandonk
Principal Engineer
FIEAust CPEng NER

Attachments

- Frames pictures by Clenergy
- Footing drawings by Gamcorp (S01-S04)

ISO 9001:2015 Registered Firm
Certificate No: AU1222

5510-2 - Compliance Letter STIII-A - 72 Cells Panels - 20220504

Page 5 of 10



Gamcorp (Melbourne) Pty Ltd A.C.N 141 076 904 A.B.N 73 015 060 240
www.gamcorp.com.au melbourne@gamcorp.com.au
 Tel: 03 9543 2211

Part Number: ER-S-STIIIA/D20

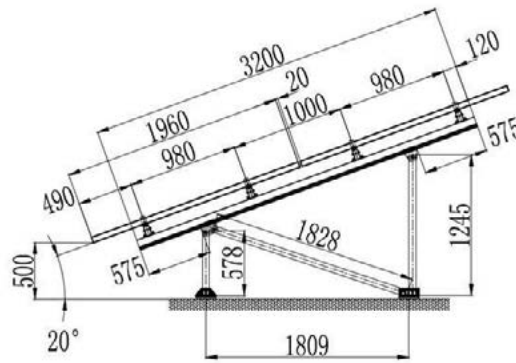

Part Number: ER-S-STIIIA/D30

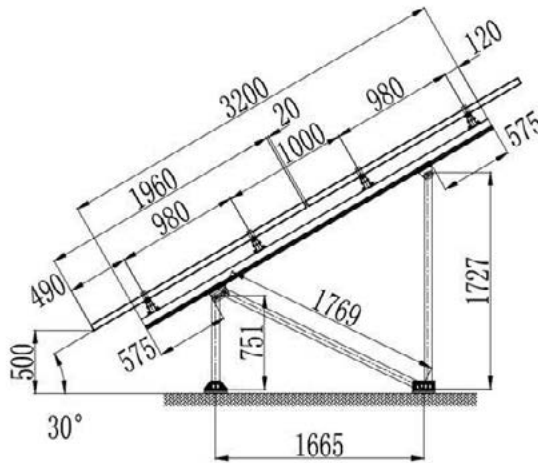

ISO 9001:2015 Registered Firm
 Certificate No: AU1222

5510-2 - Compliance Letter STIII-A - 72 Cells Panels - 20220504

Page 6 of 10



Gamcorp (Melbourne) Pty Ltd A.C.N 141 076 904 A.B.N 73 015 060 240
www.gamcorp.com.au melbourne@gamcorp.com.au
 Tel: 03 9543 2211

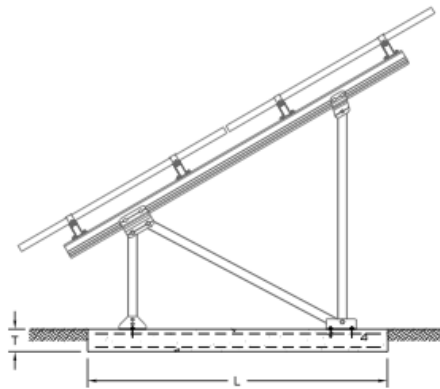

SECTION

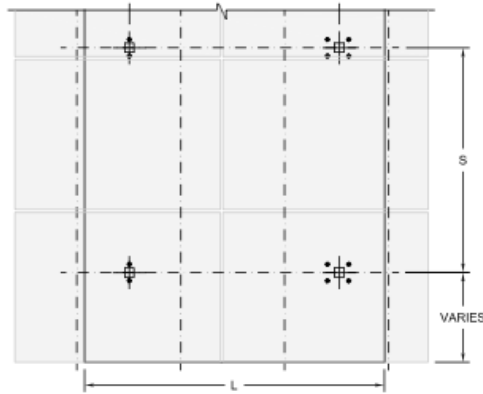

PLAN

S01. Continuous Paving Slab

ISO 9001:2015 Registered Firm
 Certificate No: AU1222

5510-2 - Compliance Letter STIII-A - 72 Cells Panels - 20220504

Page 7 of 10



Gamcorp (Melbourne) Pty Ltd A.C.N 141 076 904 A.B.N 73 015 060 240
www.gamcorp.com.au melbourne@gamcorp.com.au
 Tel: 03 9543 2211

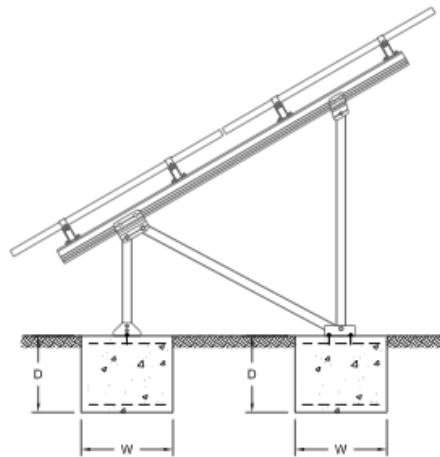

SECTION

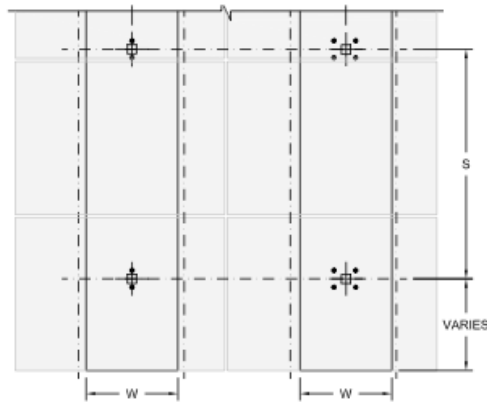

PLAN

S02. Continuous Strip Footing

ISO 9001:2015 Registered Firm
 Certificate No: AU1222

5510-2 - Compliance Letter STIII-A - 72 Cells Panels - 20220504

Page 8 of 10



Gamcorp (Melbourne) Pty Ltd A.C.N 141 076 904 A.B.N 73 015 060 240
www.gamcorp.com.au melbourne@gamcorp.com.au
 Tel: 03 9543 2211

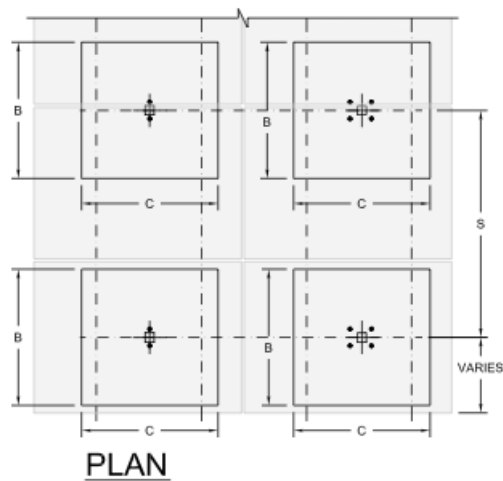
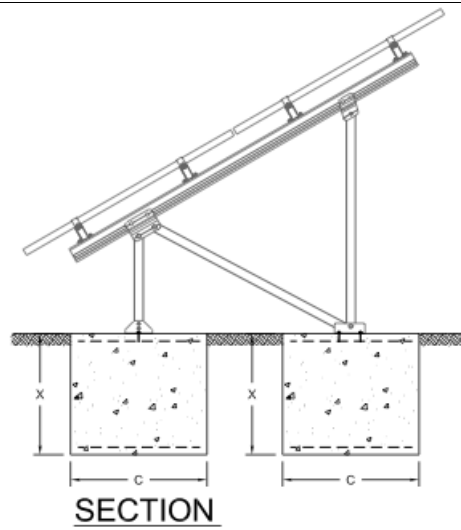

S03. Individual Pad footing per leg

ISO 9001:2015 Registered Firm
 Certificate No: AU1222



Gamcorp (Melbourne) Pty Ltd A.C.N 141 076 904 A.B.N 73 015 060 240
www.gamcorp.com.au melbourne@gamcorp.com.au
 Tel: 03 9543 2211

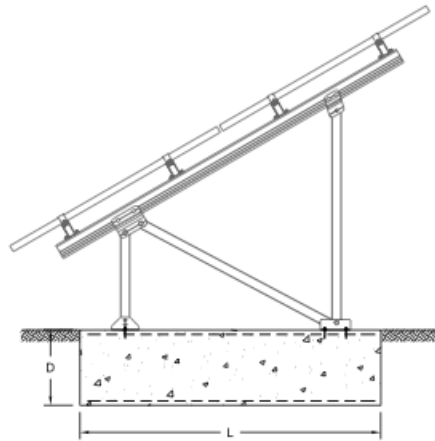

SECTION

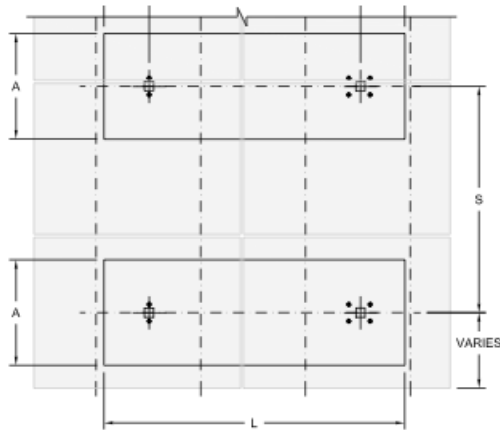

PLAN

S04. Transverse Strip Footing

ISO 9001:2015 Registered Firm
 Certificate No: AU1222



Gamcorp (Melbourne) Pty Ltd A.C.N 141 076 904 A.B.N 73 015 060 240
www.gamcorp.com.au melbourne@gamcorp.com.au
 Suite 4, 346 Ferntree Gully Rd, Notting Hill VIC 3168 Tel: 03 9543 2211

Our Ref: 8658-Rev1/AA
 3 September 2020

CLEENERGY AUSTRALIA
 1/10 Duerdin St
 Clayton VIC 3168

RE: Certification of Two Clenergy Ground Screws in 4 Soil types

Gamcorp (Melbourne) Pty Ltd, being Structural Engineers within the meaning of Australian Regulations, have carried out a structural design check of the PV-ezRack Ground Screw capacity for installation in four general soil types within Australia. The design check has been based on the drawings of the ground screws and other documents and information, provided by CLEENERGY AUSTRALIA.

Component	Part No.	Description
13-14028-200	GS-76/3.5/13-F0	Ground Screw $\phi 76 \times 3.5 \times 1300$
13-14028-201	GS-76/3.5/16-F0	Ground Screw $\phi 76 \times 3.5 \times 1600$

We find the Clenergy PV-ezRack Ground Screw to be structurally sufficient for the proposed installation, based on the following conditions:

- Maximum height above ground **150mm**;
- Ignored embedded depth **200mm**;
- Soil must not be aggressive;
- Shaft and end plate material steel **Q235B**;
- Threads material steel **Q195**;
- **85 μ m** hot dip galvanization;
- Steel design according to AS4100:1998(R2016) & AS4600:2018
- Refer to attached drawings for further details;
- Refer to **Table 1** for ultimate load capacity of ground screw L=1300mm;
- Refer to **Table 2** for ultimate load capacity of ground screw L=1600mm;

Table 1 – Ultimate load capacity for ground screw L=1300mm

Soil Type	Hard	Very Firm	Firm	Soft
Uplift (kN)	12.46	7.79	5.19	3.12
Lateral (kN)	4.28	2.67	1.78	1.07

Table 2 – Ultimate load capacity for ground screw L=1600mm

Soil Type	Hard	Very Firm	Firm	Soft
Uplift (kN)	14.18	8.86	5.91	3.55
Lateral (kN)	6.37	3.98	2.65	1.59

ISO 9001:2008 Registered Firm
 Certificate No: AU1222



Gamcorp (Melbourne) Pty Ltd A.C.N 141 076 904 A.B.N 73 015 060 240
www.gamcorp.com.au melbourne@gamcorp.com.au
 Suite 4, 346 Ferntree Gully Rd, Notting Hill VIC 3168 Tel: 03 9543 2211

Notes:

- This certification is applicable for Clenergy PV-ezRack Ground Screw with dimensions as shown in this letter.
- The ultimate loading recommendations have been calculated for the following soil conditions (AEBC indicates the soil allowable end bearing capacity):
 - Hard: Gravels; dry (hard) clays, AEBC = 240 kPa
 - Very Firm: Dry (stiff) clays; clayey sands; coarse sands; compact sands, AEBC = 150 kPa
 - Firm: Damp clays; sandy clays; damp sands, AEBC = 100 kPa
 - Soft: Wet clays; silty loams; wet or loose sands, AEBC = 60 kPa
- The soil must not be aggressive.
- Site-specific soil report shall be made available to justify the soil conditions.
- This certificate is only valid as a whole. Any information extracted from this certificate is not valid if standing alone.
- If any of the above conditions cannot be met, the structural engineer must be notified immediately.

In case the above listed Ground Screws are installed in combination with SolarTerrace III-A please apply the below spacing changes:

STIII-A, Panel size 1700x1100mm-Spacing coefficient (#5510-1)*

WR		A		B		C	D
Tilt angle		20	30	20	30	20	20
Soil Type	Hard	1	0.83	1	0.63	0.78	0.65
	Very Firm	0.91	0.52	0.66	0.38	0.5	0.41
	Firm	0.61	0.34	0.44	0.25	0.34	0.29
	Soft	0.37	0.22	0.27	0.16	0.19	0.16

STIII-A, Panel size 2000x1100mm-Spacing coefficient (#5510-2)*

WR		A		B		C	D
Tilt angle		20	30	20	30	20	20
Soil Type	Hard	1	0.74	0.94	0.58	0.7	0.68
	Very Firm	0.81	0.45	0.6	0.34	0.43	0.42
	Firm	0.53	0.32	0.4	0.24	0.3	0.26
	Soft	0.33	0.19	0.23	0.14	0.17	0.16

*** Front leg ground screw L=1300mm, Rear leg ground screw L=1600mm**

ISO 9001:2008 Registered Firm
 Certificate No: AU1222



Gamcorp (Melbourne) Pty Ltd A.C.N 141 076 904 A.B.N 73 015 060 240
www.gamcorp.com.au melbourne@gamcorp.com.au
 Suite 4, 346 Ferntree Gully Rd, Notting Hill VIC 3168 Tel: 03 9543 2211

Construction is to be carried out strictly in accordance with the manufacturers instructions and site soil report recommendations. This work was designed by **Ali Askari** in accordance with the provisions of relevant Regulations and in accordance with sound, widely accepted engineering principles.

Yours faithfully,
 Gamcorp (Melbourne) Pty Ltd

Behrooz Ghaemi
Behrooz Ghaemi
 Principal Engineer
 MIEAust NER 4152159
 QLD Registration: 22715
 VIC Registration: EC 62562
 TAS Registration: 094108016

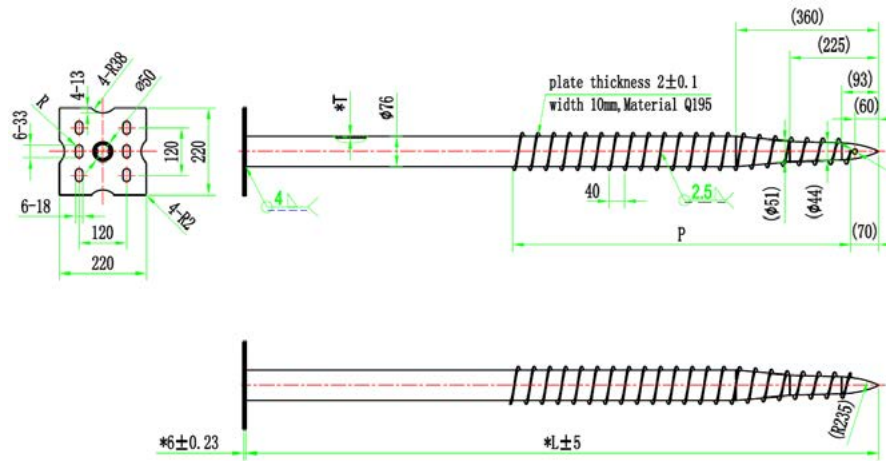

No.	BarCode	L	P	T	Weight (Kg)
1	13-14028-200	1300	860	3.5±0.2	10.351
2	13-14028-201	1600	860	3.5±0.2	12.126

ISO 9001:2008 Registered Firm
 Certificate No: AU1222







PV-ezRACK®

Clenergy

1/10 Duerdin St
Clayton VIC 2168
Australia

Phone: +61 3 9239 8088
Email: sales@clenergy.com.au
Web: www.clenergy.com.au

 @ClenergyGlobal / @ClenergyClub / ClenergyAUS  @Clenergy  @ClenergyClub
 @Clenergy_global  @Clenergy

A Clenergy Technologies Company